



RULES FOR COMPETITION
INCORPORATING IAAF RULES
EFFECTIVE FROM 1ST APRIL 2018

£5.50

**INTERNATIONAL ASSOCIATION OF ATHLETICS FEDERATIONS
UK ATHLETICS**

**COMPETITION RULES
FOR USE IN THE UK
1st April 2018 – 31st March 2020**

IAAF RULES IN FORCE AS FROM 1ST NOVEMBER 2017

UK Athletics
Athletics House
Alexander Stadium
Walsall Road
Perry Barr
Birmingham B42 2BE

Jason Gardener M.B.E. - President
Richard Bowker - Chair
Niels de Vos - Chief Executive
Tel: 0121 713 8400
W: www.uka.org.uk
E: rules@uka.org.uk

UK Athletics Ltd. ISBN: 978-0-9547401-5-3

TABLE OF CONTENTS

	<i>Page</i>
LIST OF IAAF RULES	5
UKA APPENDICES	8
DEFINITIONS	9
INTERNATIONAL COMPETITIONS	15
ELIGIBILITY	30
ANTI-DOPING AND BETTING	52
TECHNICAL RULES	53
SECTION I – OFFICIALS	54
SECTION II – GENERAL COMPETITION RULES	72
SECTION III – TRACK EVENTS	109
SECTION IV – FIELD EVENTS	163
A. VERTICAL JUMPS	174
B. HORIZONTAL JUMPS	190
C. THROWING EVENTS	198
SECTION V – COMBINED EVENTS COMPETITIONS	239
SECTION VI – INDOOR COMPETITIONS	244
SECTION VII – RACE WALKING EVENTS	254
SECTION VIII – ROAD RACES	261
SECTION IX – CROSS-COUNTRY, MOUNTAIN AND TRAIL RACES	270
SECTION X – WORLD RECORDS	280
INDEX OF TECHNICAL RULES	353

OFFICERS OF UKA GROUPS

UK ATHLETICS ADVISORY GROUPS

DOMESTIC STRATEGY

Contact: Nigel Holl, UKA, Alexander Stadium, Walsall Road, Perry Barr, Birmingham, B42 2BE; Tel: 0121 713 8400; E: nholl@uka.org.uk

TECHNICAL

Chair: Linda Turner, UKA, Alexander Stadium, Walsall Road, Perry Barr, Birmingham, B42 2BE; Tel: 0121 713 8400; E: lturner@uka.org.uk

OFFICIALS GROUP

Coordinator: Andrew Clatworthy, 26 Columba Drive, Leighton Buzzard, Beds. LU7 3YN; Tel: 01525 371186; E: ajc.athletics@btinternet.com

UKA RULES GROUP

Tim Soutar (Chair), Nigel Holl, Chris Cohen CBE, Keith Davies, John Temperton (Administrator)

Contact: John Temperton, UKA, Alexander Stadium, Walsall Road, Perry Barr, Birmingham, B42 2BE; Tel: 0121 713 8400; E: rules@uka.org.uk

ENDURANCE

Contact: John Temperton, UKA, Alexander Stadium, Walsall Road, Perry Barr, Birmingham, B42 2BE; Tel: 0121 713 8400; E: jtemperton@uka.org.uk

NATIONAL ASSOCIATIONS

ENGLAND ATHLETICS

Alexander Stadium, Walsall Road, Perry Barr, Birmingham, B42 2BE;
Tel: 0121 347 6543; Fax: 0121 347 6544; www.Englandathletics.org

Tri-Regional Officials:

South: David Vidler, 4 Quarter Gate, South Woodham Ferrers, Chelmsford, Essex, CM3 5GT; Tel: 01245 323179; E: miveld.vidler@btinternet.com

Midlands & South West: Barry Parker, 26 Field Drive, Alvaston, Derby, DE24 0HF; Tel: 01332 753933; E: parkerbarry47@gmail.com

North: Paul Yates, 29 Chadwick Road, Eccles, Lancashire, M30 0WU; Tel: 07905 340077; E: paulwilliamyates@hotmail.com

ATHLETICS NORTHERN IRELAND

Athletics House, Old Coach Road, Belfast, BT79 5PR; Tel: 028 9060 2707;
Fax: 028 9030 9939; www.niathletics.org

Officials' Development: Liz Glover, 61 Ardenlee Avenue, Belfast, BT6 0AB; E: lizglover@hotmail.co.uk

SCOTTISH ATHLETICS LTD

Caledonia House, South Gyle, Edinburgh, EH12 9DQ; Tel: 0131 539 7320;
www.scottishathletics.org.uk

Officials' Convenor: Margaret Brown, 15 Glenside Court, Armadale, West Lothian, EH48 3RX; Tel: 07903 207802; E: mbb626@hotmail.co.uk

WELSH ATHLETICS LTD

Cardiff International Sports Stadium, Leckwith Road, Cardiff, CF11 8AZ;
Tel: 029 2064 4870; Fax: 029 1034 2687; www.welshathletics.org

Officials' Convenor (Track & Field): Sue Hooper, 28 Mill Common, Undy, Caldicot, Monmouthshire, NP26 3JH; Tel: 01633 881608;
E: hooper_pencoed@btinternet.com

Endurance Officials' Secretary: John Chidlow, 7 Troddi Close, Caldicot, Monmouthshire, NP26 4PW; Tel: 01291 431403; E: jcewathletics@gmail.com

LIST OF IAAF RULES

<i>Rule</i>	<i>Page</i>
LIST OF IAAF RULES	5
DEFINITIONS	9
INTERNATIONAL COMPETITIONS	15
RULE 1 International Competitions	15
RULE 2 Authorisation to Stage Competitions	16
RULE 3 Regulations Governing the Conduct of International Competitions	22
RULE 4 Requirements to Compete in International Competitions	23
RULE 5 Eligibility to Represent a Member	24
RULE 6 Payments to Athletes	26
RULE 7 Athletes' Representatives	26
RULE 8 Advertising and Displays during International Competitions	28
ELIGIBILITY	30
RULE 20 Definition of Eligible Athlete	30
RULE 21 Restriction of Competition to Eligible Athletes	30
RULE 23 Persons Subject to Declaration of Ineligibility	50
ANTI-DOPING AND BETTING	52
RULE 30 S 1 UKA Supplement Anti-Doping	52
RULE 60 S 1 UKA Supplement Betting	52
TECHNICAL RULES [RULES 100 TO 265]	
RULE 100 General	53
SECTION I – OFFICIALS	54
RULE 110 International Officials	54
RULE 111 Organisational Delegates	55
RULE 112 Technical Delegates	55
RULE 113 Medical Delegate	56
RULE 114 Anti-Doping Delegate	57
RULE 115 International Technical Officials (ITOs)	57
RULE 116 International Race Walking Judges (IRWJs)	58

RULE 117 International Road Course Measurer	58
RULE 118 International Starter and International Photo Finish Judge	59
RULE 119 Jury of Appeal	59
RULE 120 Officials of the Competition	60
RULE 125 Referees	63
RULE 132 Competition Secretary, Technical Information Centre (TIC)	69
SECTION II – GENERAL COMPETITION RULES	72
RULE 140 The Athletics Facility	72
RULE 141 Age and Sex Categories	72
RULE 142 Entries	81
RULE 143 Clothing, Shoes and Athlete Bibs	86
RULE 144 Assistance to Athletes	91
RULE 145 Effect of Disqualification	94
RULE 146 Protests and Appeals	96
RULE 147 Mixed Competition	104
RULE 148 Surveying and Measurements	106
RULE 149 Validity of Performances	106
RULE 150 Video Recording	108
RULE 151 Scoring	109
SECTION III – TRACK EVENTS	109
RULE 160 Track Measurements	109
RULE 161 Starting Blocks	112
RULE 162 The Start	114
RULE 163 The Race	121
RULE 164 The Finish	128
RULE 165 Timing and Photo Finish	129
RULE 166 Seedings, Draws and Qualification in Track Events	135
RULE 167 Ties	142
RULE 168 Hurdle Races	143
RULE 169 Steeplechase Races	150
RULE 170 Relay Races	157
SECTION IV – FIELD EVENTS	163
RULE 180 General Conditions – Field Events	163
RULE 181 General Conditions – Vertical Jumps	174
RULE 182 High Jump	178
RULE 183 Pole Vault	182
RULE 184 General Conditions – Horizontal Jumps	190
RULE 185 Long Jump	193
RULE 186 Triple Jump	196

RULE 187 General Conditions – Throwing Events	198
RULE 188 Shot Put	210
RULE 189 Discus Throw	214
RULE 190 Discus Cage	218
RULE 191 Hammer Throw	220
RULE 192 Hammer Cage	226
SECTION V – COMBINED EVENTS COMPETITIONS	239
RULE 200 Combined Events Competitions	239
SECTION VI – INDOOR COMPETITIONS	244
RULE 210 Applicability of Outdoor Rules to Indoor Competitions	244
RULE 211 The Indoor Stadium	244
RULE 212 The Straight Track	245
RULE 213 The Oval Track and Lanes	246
RULE 214 Start and Finish on the Oval Track	247
RULE 215 Draw for Lanes in Track Events	249
RULE 216 Clothing, Shoes and Athlete Bibs	250
RULE 217 Hurdle Races	250
RULE 218 Relay Races	250
RULE 219 High Jump	251
RULE 220 Pole Vault	251
RULE 221 Horizontal Jumps	251
RULE 222 Shot Put	251
RULE 223 Combined Events Competitions	253
SECTION VII – RACE WALKING EVENTS	254
RULE 230 Race Walking	254
SECTION VIII – ROAD RACES	261
RULE 250 Road Races	261
SECTION IX – CROSS-COUNTRY, MOUNTAIN AND TRAIL RACES	270
RULE 251 Cross-Country Races	270
RULE 252 Mountain Races	274
RULE 253 Trail Races	276
SECTION X – WORLD RECORDS	280
RULE 260 World Records	280
RULE 261 Events for which World Records are Recognised	287
RULE 262 Events for which World U20 Records are Recognised	289
RULE 263 Events for which World Indoor Records are Recognised	290
RULE 264 Events for which World U20 Indoor Records are Recognised	291
RULE 265 Other Records	297

SPECIFIC UKA DOMESTIC RULES

**THESE ARE SHOWN IN PURPLE FOLLOWING
THE APPROPRIATE IAAF RULE**

UKA APPENDICES

<i>Rule</i>	<i>Page</i>
Appendix 1: Rules for Ultra Distance Road & Track Races	298
Appendix 2: Technical Officials' Pathway (Track & Field)	305
Appendix 3: Appointment of, Duties of & Selection of Officials	316
Appendix 4: Endurance Running	330

UKA has accepted that IPC Rules for Competition will apply to Disability competitions held in the UK. IPC Rules are available at <http://www.paralympic.org/athletics/rules-and-regulations/rules> and on request from UKA.

The Board of UKA retain the right to apply appropriate Rules changes within the period this rule book covers. Should any changes be made information will be published on the UKA website at <http://www.uka.org.uk/competitions/rules/> and directly by e-mail to licensed Technical Officials.

DEFINITIONS

Area

The geographical area comprising all of the Countries and Territories affiliated to one of the six Area Associations.

Area Association

An Area Association of the IAAF responsible for fostering Athletics in one of the six areas into which the Members are divided in the Constitution.

Athletes' Representative

A person who is duly authorised and registered as an Athletes' Representative in accordance with the IAAF Athletes' Representative Regulations.

Athletes' Representative Regulations

The IAAF Athletes' Representative Regulations as may be passed by the Council from time.

Athletes Support Personnel

Any coach, trainer, manager, Athlete Representative, agent, team staff, official, medical or para-medical personnel, parent or any other Person employed by or working with an Athlete or Athlete's National Federation participating in an International Competition.

Athletics

Track and Field, Road Running, Race Walking, Cross-Country Running, Mountain Running and Trail Running.

CAS

Court of Arbitration for Sport, which is an independent arbitration body seated in Lausanne, Switzerland.

Citizen

A person who has legal Citizenship of a Country or, in the case of a Territory, legal Citizenship of the Territory's parent Country and appropriate legal status in the Territory under applicable laws.

Citizenship

Legal citizenship of a Country or, in the case of a Territory, legal citizenship of the Territory's parent Country and appropriate legal status in the Territory under applicable laws.

Club

A club or society of athletes, directly or through a body, affiliated to a Member in accordance with the rules of the Member.

Commission

A Commission of the IAAF that has been appointed by the Council under the terms of the Constitution.

Constitution

The IAAF Constitution.

Council

The IAAF Council.

Country

A self-governing geographical area of the world recognised as an independent state by international law and international governmental bodies.

IAAF

The International Association of Athletics Federations.

International Competitions

The competitions in the World Athletics Series (as described in the Rules), the Athletics programme of the Olympic Games and other competitions organised by or on behalf of the IAAF or as specified in the Rules and Regulations.

International Invitation Meeting

Athletics competition in which athletes affiliated to two or more Members participate by invitation of the Meeting Organiser.

International-Level Athlete

An athlete who is in the Registered Testing Pool or who is competing in an International Competition as defined in the Anti-Doping Rules.

IOC

International Olympic Committee.

Member

A national governing body for Athletics affiliated to the IAAF.

Membership

Membership of the IAAF.

National Federation

The Member of the IAAF to which an athlete or other person under the Constitution is affiliated directly or through club or another body affiliated to a Member.

Neutral Athlete

As specified in Rule 22.1a, an athlete who is granted special eligibility by the Council to compete in one or more International Events in an individual capacity and who satisfies at all relevant times any conditions to such eligibility specified by the Council. All provisions in the Rules and Regulations that are applicable to athletes shall apply equally to Neutral Athletes, unless expressly stated otherwise; and any coach, trainer, manager, Athlete Representative, agent, team staff, official, medical or para-medical personnel, parent or any other Person employed by or working with a Neutral Athlete participating in an International Competition shall be an Athlete Support Personnel for purposes of these Rules.

Regulations

The Regulations of the IAAF as may be passed by the Council from time to time.

Residence

Residence is the place or location in which the athlete is registered with relevant authorities as having his primary and permanent home.

Rules

The Rules of the IAAF, including the Competition Rules (which include the Technical Rules), the Former Code of Ethics, the Integrity Code of Conduct, the Rules of Congress Procedure and such other rule as approved from time to time in accordance with the Constitution.

Technical Rules

The Rules describing the Technical Rules of Competition in Athletics as contained in the IAAF Competition Rules.

Territory

A geographical territory or region which is not a Country, but which has certain aspects of self-government, at least to the extent of being autonomous in the control of its sport and which is thus recognised as such by the IAAF.

World Athletics Series

The major International Competitions in the IAAF's four-yearly official competition programme.

Note (i): The above definitions apply to all Rules except where the same terms are also defined in the Anti-Doping Rules e.g., International Competition, in which case the above definitions apply to all Rules except the Anti-Doping Rules.

Note (ii): All references in the Rules to the masculine gender shall also include references to the feminine and all references to the singular shall also include references to the plural.

Note (iii): The notes in green print (previously in the IAAF publication “The Referee” - “Le Juge Arbitre”) provide interpretation to the Competition Rules and practical guidance for their implementation.

Note (iv): Amendments (other than editorial amendments) to the corresponding Rules in the IAAF Competition Rules 2018-2019 approved by the Council, are marked by double lines in the margin and are applicable from 1st November 2017 unless otherwise stated.

UKA SUPPLEMENT

UKA PREAMBLE & DEFINITIONS

UK Athletics Rules for Competition, supported by the Articles of Association, define affiliation to a National Association as a prerequisite for entry to competition. The National Associations to which these apply are: England Athletics Ltd, Athletics Northern Ireland Ltd, Scottish Athletics Ltd. and Welsh Athletics Ltd.

These Associations will operate and maintain affiliation and registration schemes, including the responsibility to levy club affiliation and athlete registration fees, and are required to describe the conditions associated with such fees from time to time.

Membership of clubs or individuals with UK Athletics is granted automatically on affiliation to any of the National Associations. UK Athletics has delegated responsibility for governance functions to the National Associations.

Other Organisations, Associations or Competition Providers within the sport may request that a Club should become a member of that Competition Provider in order to participate in its activities.

UKA have adopted IAAF rules for the regulation of the sport of Athletics unless hereinafter varied.

The Board of UK Athletics is responsible for the interpretation of UKA Rules, and the final adjudication of any dispute.

Definitions:

The following terms used throughout the Rules are defined here:

UK Athletics (UKA)

The Member Federation of the IAAF responsible for athletics in the United Kingdom of Great Britain and Northern Ireland.

British Athletics

The consumer brand of the governing body UK Athletics.

National Association (hereafter referred to as 'Association')

England Athletics Ltd, Athletics Northern Ireland Ltd, Scottish Athletics, Welsh Athletics Ltd.

Region

A smaller unit of England Athletics for administrative purposes.

District

A geographical sub-division of Scotland having a separate Committee for administrative purposes.

Area

A geographical sub-division of England having a separate Committee for competition purposes only.

Club

Affiliated Club including affiliated University, College, School or Services Unit.

Competition Provider

Any organisation approved by UKA that is authorised to promote Athletics in the UK. Those Organisations listed above are deemed to be authorised Competition Providers.

Licence

Written authority to promote an event granted by UKA or a National Association applying the terms and standards currently in force.

Where the words ‘must’ and ‘shall’ are used the Rule is compulsory. Where ‘should’ is employed, while UK Athletics expects that the Rule will be observed, strict compliance is not essential.

The Rules for Competition cover all disciplines of athletics.

The management of Fell, Hill and Mountain Running is delegated to National Committees:

- (a) Fell Runners’ Association Ltd. (England)
- (b) Scottish Athletics Ltd. Hill Running Commission
- (c) Welsh Athletics Ltd.
- (d) Northern Ireland Mountain Running Association

The management of Trail Running is delegated to the Trail Running Association

INTERNATIONAL COMPETITIONS

RULE 1 INTERNATIONAL COMPETITIONS

1. The following are International Competitions:
 - (a) (i) Competitions included in the World Athletics Series.
 - (a) (ii) The Athletics programme of the Olympic Games.
 - (b) The Athletics programme of Area, Regional or Group Games not confined to participants from a single Area where the IAAF does not have exclusive control.
 - (c) Regional or Group Championships in Athletics not confined to participants from a single Area.
 - (d) Matches between teams from different Areas representing Members or Areas or combinations thereof.
 - (e) International Invitation Meetings and competitions that are categorised by the IAAF as part of the global structure and approved by the Council.
 - (f) Area Championships and other intra-Area competitions organised by an Area Association.
 - (g) The Athletics programme of Area, Regional or Group Games, and Regional or Group Championships in Athletics confined to participants from a single Area.
 - (h) Matches between teams representing two or more Members or combinations thereof within the same Area, with the exception of U18 and U20 category competitions.
 - (i) International Invitation Meetings and competitions, other than those referred to in Rule 1.1(e), where appearance fees, prize money and/or the value of non-cash prizes exceed USD 50,000 in total, or USD 8,000 for any one event.
 - (j) Area programmes similar to those referred to in Rule 1.1(e).
2. The Rules shall apply as follows:
 - (a) The Eligibility Rules, the Rules governing Disputes and the Technical Rules shall apply to all International Competitions. Other international organisations recognised by the IAAF may have and enforce more restrictive eligibility requirements for competitions conducted under their jurisdiction.

- (b) The Anti-Doping Rules shall apply to all International Competitions (save as otherwise expressly stated), except that, where the IOC, or another international organisation recognised by the IAAF for such purpose, carries out doping control at a competition under their rules, such as the Olympic Games, those rules shall govern to the extent applicable.
- (c) The Advertising Rule (Rule 8) shall apply to all International Competitions listed in Rules 1.1(a)(i), (c), (d), and (e). Area Associations may promulgate their own advertising regulations to apply to the International Competitions listed in Rules 1.1(f), (g), (h), (i) and (j), failing which those of the IAAF shall apply.
- (d) Rules 2 to 7 shall apply to all International Competitions, except to the extent any Rule specifically limits its applicability.

RULE 2 AUTHORISATION TO STAGE COMPETITIONS

1. The IAAF is responsible for supervising a global competition system in cooperation with the Area Associations. The IAAF shall coordinate its competition calendar and those of the respective Area Associations in order to avoid or minimise conflicts. All International Competitions must be authorised by the IAAF or an Area Association in accordance with this Rule 2. Any combination or integration of International Meetings into a Series / Tour or League requires a permit from the IAAF or the concerned Area Association including the necessary regulation or contractual condition for such an activity. The operation may be delegated to a third party. In the event that an Area Association fails properly to manage and control International Competitions in accordance with these Rules, the IAAF shall be entitled to intervene and take such steps as it deems necessary.
2. The IAAF alone shall have the right to organise the Athletics competition at the Olympic Games and the competitions that are included in the World Athletics Series.
3. The IAAF shall organise a World Championships in odd-numbered years.
4. Area Associations shall have the right to organise Area Championships and they may organise such other intra-Area events as they deem appropriate.

Competitions Requiring an IAAF Permit

5. (a) An IAAF permit is required for all International Competitions listed in Rules 1.1(b), (c), (d) and (e).
- (b) An application for a permit must be made to the IAAF by the Member in whose Country or Territory the International Competition is to take place not later than 12 months prior to the competition, or such other deadline as may be established by the IAAF.

Competitions Requiring an Area Association Permit

6. (a) An Area Association Permit is required for all International Competitions listed in Rules 1.1(g), (h), (i), and (j). Permits for International Invitation Meetings or competitions where appearance fees, prize money and/or the value of non-cash prizes exceed USD 250,000 in total, or USD 25,000 for any one event, shall not be issued prior to the Area Association's consultation with the IAAF regarding the date.
- (b) An application for a permit must be made to the appropriate Area Association by the Member in whose Country or Territory the International Competition is to take place not later than 12 months prior to the competition, or such other deadline as may be established by the Area Association.

Competitions Authorised by a Member

7. Members may authorise national competitions, and foreign athletes may participate in those competitions, subject to Rules 4.2 and 4.3. If foreign athletes do participate, appearance fees, prize money, and/or non-cash prizes for all athletes at such national competitions shall not exceed USD 50,000 in total, or USD 8,000 for any one event. No athlete may participate in any such competition if he is ineligible to participate in the sport of Athletics under the Rules of the IAAF, the host Member, or the National Federation to which he is affiliated.

RULE 2 S 1 UKA SUPPLEMENT PERMISSION TO PROMOTE

- (1) This Rule applies to all disciplines of athletics as defined in Rule 21 S2(4).
- (2) All events, other than those identified in (3) below, require Licences as set out below
- (3) Provided they conform to UKA Rules for Competition the following athletic events do not require specific permission:
 - (i) Events promoted by, and confined to employees (and their relatives) of any particular business entity.
 - (ii) Events promoted by, and confined to, HM Services.
 - (iii) Events promoted by, and confined to members of schools or an Education Authority, pre-service organisation or other recognised juvenile organisation, provided that the relevant National or County Association is affiliated to the appropriate National Association.
 - (iv) Track and Field Events classified as Level 1 where recognition of performances is not required.

NOTE: Explanation for the divisions into Competition Levels is available in diagram form at <http://uka.org.uk/competitions/track-field-licensing/>

- (4) Permission to promote will be granted by UK Athletics. UKA may make such procedural arrangements (including delegation to other bodies) for the administration of its powers as it sees necessary. It shall hereinafter be called the Licensing Authority.
- (5) The Licensing Authority shall publish the conditions for licences to be granted which may be varied from time to time.
- (6) Applications for permission to promote must be made on the standard form approved for the purpose and be accompanied by the appropriate fee. The submission to the Licensing Authority shall contain such additional information as that Authority may reasonably require. The Licensing Authority has discretion whether to grant or refuse permission and shall be entitled to apply to a grant of permission such conditions as it thinks appropriate.
- (7) Applications must be made at least eight weeks before the proposed date of the event.
- (8) Applications must include undertakings by the applicant to:
 - (i) Adopt and comply with UKA Rules for Competition.

- (ii) Include the words ‘Under UKA Rules’ upon all advertising, programmes and printed material issued in connection with the athletic event.
 - (iii) Organise and manage the event to the appropriate standard and comply with any additional requirements or conditions of the Licensing Authority.
 - (iv) Clearly display the Licence at the venue and be available for inspection.
- (9) Any Body that promotes or is involved in the promotion of any athletics event in contravention of this Rule shall be liable to disciplinary action by the National Association, and any person taking part in such a competition who is aware of any suspension may thereby be liable to disqualification from competing under UKA Rules for a specified time.

RULE 2 S 2 UKA SUPPLEMENT UKA LICENCES

(1) TRACK and FIELD

- (i) Licences are required for Track and Field competitions as indicated below:
 - (a) Competition Providers of competitions classified as Level 2 must obtain a Licence from UKA.
 - (b) Competition Providers of competitions classified as Level 1 held within the boundaries of England, Northern Ireland, Scotland or Wales must obtain a Licence from the appropriate Home Country Association or from UKA for UK wide competitions.
- (ii) The maximum time allowed for a track and field competition held under a UKA Licence will be 8 hours unless a separate group of officials is provided. The 8 hours will commence at the programmed time of the first event and be completed at the scheduled finish time of the final event.
- (iii) On the first failure to comply a warning will be issued to the Competition Provider and subsequent failures may result in the withholding of a Licence.

(2) RACE WALKING

All Open Race Walking events require specific permission to stage events. Applications for permission to promote events should be sent together with a fee (as determined by the appropriate issuing authority) to the appropriate Honorary Secretary:

- (i) For events to be held in England to the RWA Honorary Secretary.
- (ii) For events to be held in Northern Ireland, Scotland or Wales to the appropriate National Association.

An OPEN event is defined as one open to all eligible athletes and all eligible affiliated Clubs, including one restricted to a particular County District and/or age group. (See Rule 21 S6)

(3) CROSS COUNTRY

Any Competition Provider granted a Cross Country Licence by the Licensing Authority must impose, in addition to the basic entry fee, an additional fee of £2 (to be known as the ‘Additional Unattached Entry Fee’) on every entrant in an Open Senior Cross Country race who is not a member of a Club affiliated to a National Association and who does not have a current individual registration with their National Association. Any additional entry fees collected are payable to the Licensing Authority within one month of the date of the competition and must be accompanied by copies of the full entry list and results.

(4) ROAD RACES

UKA has delegated the responsibility for licensing road races to the National Associations and subsequently England Athletics and Welsh Athletics have appointed runbritain to manage the process on their behalf.

- (i) Any Competition Provider affiliated to a National Association wishing to hold a road race must:
 - (a) Consult the Local Authority Safety Advisory Group or equivalent and inform the relevant Local Authorities and Emergency Services
 - (b) Obtain a Road Race Licence from the UKA Licensing Authority
 - (c) Comply with the requirements of UKA Licence Standards.

- (ii) The following shall be deemed to be a race under UKA Rules and will require the issue of a Road Race Licence before they can be held:
 - (a) Events in which awards or prizes are given in accordance with the finishing order of runners and/or
 - (b) Events which pay appearance money or otherwise contract athletes to appear.
 - (iii) All Competition Providers who wish to stage any road race must apply for a UKA Road Race Licence in the manner specified by the National Association. Failure to comply with the requirements of the Licensing Authority in the issue of a Race Licence may lead to the withholding of future licences to the Competition Provider or such person as the Authority deems fit.
 - (iv) The appropriate Association shall have the power to reduce or waive the Licence Fee.
 - (v) Any Competition Provider to whom a Road Race Licence has been granted by UKA must:
 - (a) Insert the words 'Under UKA Rules' and the unique Licence Code as issued to the race when the licence is granted, upon all printed matter associated with the Road Race.
 - (b) Grant a minimum discount of £2 from the advertised race entry fee in Senior competitions to a member of a Club affiliated to a National Association and who has a current individual registration with their National Association.
 - (c) Within one month of the race being staged, submit designated reports to meet National Association requirements, including access to entry and result lists.
- (5) **FELL, HILL and MOUNTAIN RUNNING**
All official UKA Fell, Hill and Mountain Running Races must be registered with one of the National Committees. The registration shall be effected by supplying to the nominated officer of the relevant body details of the race on the form provided and by its subsequent appearance in a published calendar / fixture list /magazine supplement. A nominal charge may be made to cover calendar publication expenses and race insurance.

(6) TRAIL RACES

- (i) Competition Providers of Trail Races must obtain a UK Athletics race licence. They are available from the Trail Running Association (TRA) or the appropriate National Association.
- (ii) Any Competition Provider granted a Trail Running Licence by UKA must impose, in addition to the basic entry fee, an additional fee of £2 (to be known as the ‘Additional Unattached Entry Fee’) on every entrant in a Senior Open Trail Running race who is not a member of a Club affiliated to a National Association or is not a registered member of the TRA. Any additional entry fees collected are payable to the Licensing Authority within one month of the date of the competition and must be accompanied by copies of the full entry list and results.
- (iii) As indicated in (ii) above, members of the TRA are not liable to pay the Additional Unattached Entry Fee imposed on Trail races. This applies whether or not the TRA granted a race licence for the race in question.

RULE 3 REGULATIONS GOVERNING THE CONDUCT OF INTERNATIONAL COMPETITIONS

- 1. The Council may produce Regulations governing the conduct of International Competitions held under the Rules and regulating the relationships of athletes, athletes’ representatives, meeting organisers and Members. These Regulations may be varied or amended by the Council as it sees fit.
- 2. The IAAF and Area Associations may designate one or more representatives to attend every International Competition requiring an IAAF or Area Association Permit respectively to ensure that the applicable Rules and Regulations are complied with. At the request of the IAAF or Area Association respectively, such representative(s) shall render a compliance report within 30 days of the end of the International Competition in question.

RULE 4 REQUIREMENTS TO COMPETE IN INTERNATIONAL COMPETITIONS

1. No athlete may take part in an International Competition unless he:
 - (a) is a member of a Club affiliated to a Member; or
 - (b) is himself affiliated to a Member; or
 - (c) has otherwise agreed to abide by the rules of a Member; or
 - (d) has been granted special eligibility by the Council to compete in that International Competition as a Neutral Athlete, and has satisfied any conditions to such eligibility specified by the Council; and
 - (e) for International Competitions at which the IAAF is responsible for doping control, has signed an agreement in a form set by the IAAF by which he agrees to be bound by the Rules and Regulations (as amended from time to time) and to submit all disputes he may have with the IAAF or a Member to arbitration only in accordance with these Rules, accepting not to refer any such disputes to any Court or authority which is not provided for in these Rules.
2. Members may require that no athlete or Club affiliated to the Member may take part in an International Competition in a foreign Country or Territory without the Member's written approval. In such a case, no Member hosting a competition shall allow any foreign athlete or Club of the Member in question to take part without evidence of such permit certifying that the athlete or Club is eligible and permitted to compete in the Country or Territory concerned. Members shall notify the IAAF of all such permit requirements. To facilitate compliance with this Rule, the IAAF shall maintain on its website a list of Members with such requirements. This Rule does not apply to Neutral Athletes.
3. No athlete affiliated to a National Federation may be affiliated to another Member without previous authorisation from his National Federation of origin, if the rules of that Federation require such authorisation. Even then, the National Federation of the Country or Territory in which the athlete is residing cannot enter any athlete's name for competitions in another Country or Territory without

previous authorisation from the National Federation of origin. In all cases under this Rule, the National Federation of the Country or Territory in which the athlete is residing shall send a written request to the athlete's National Federation of origin, and the National Federation of origin shall send a written reply to that request within 30 days. Both of these communications shall be by a means that generates an acknowledgement of receipt. E-mail that includes a receipt function is acceptable for this purpose. If the response of the athlete's National Federation of origin is not received within the 30-day period, the authorisation shall be deemed to have been given.

In the event of a negative response to a request for authorisation under this Rule, which response must be supported by reasons, the athlete or the National Federation of the Country or Territory in which the athlete is residing may appeal against any such decision to the IAAF. The IAAF shall publish guidelines for the filing of an appeal under this Rule and these guidelines shall be available on the IAAF website. To facilitate compliance with this Rule, the IAAF shall maintain on its website a list of National Federations with such authorisation requirements.

Note: Rule 4.3 concerns athletes aged 18 or over as at the 31st of December of the year in question. The Rule does not apply to athletes who are not Citizens of a Country or Territory or to political refugees or to Neutral Athletes.

RULE 5 ELIGIBILITY TO REPRESENT A MEMBER

1. In International Competitions held under Rules 1.1(a), (b), (c), (f) or (g), Members shall be represented only by athletes who are Citizens of the Country (or Territory) which the affiliated Member represents and who comply with the eligibility requirements of this Rule 5.
2. An athlete who has never competed in an International Competition under Rules 1.1(a), (b), (c), (f) or (g) shall be eligible to represent a Member in an International Competition under Rules 1.1(a), (b), (c), (f) or (g) if he is a Citizen of the Country (or Territory) by virtue of having been born or by virtue of having a parent or grandparent born in the Country (or Territory).

3. Subject to Rule 5.4, an athlete who has represented a Member in an International Competition held under Rules 1.1(a), (b), (c), (f) or (g) shall not be eligible to represent another Member in an International Competition held under Rules 1.1(a), (b), (c), (f) or (g).
4. An athlete who has represented a Member in an International Competition under Rules 1.1(a), (b), (c), (f) or (g) shall be eligible to represent another Member in an International Competition under Rules 1.1(a), (b), (c), (f) or (g) (with immediate effect unless otherwise stated) in the following circumstances only:
 - (a) if the Country (or Territory) of the Member is subsequently incorporated in another Country that is or subsequently becomes a Member;
 - (b) if the Country (or Territory) of the Member ceases to exist and the athlete becomes a Citizen as of right of a newly formed Country ratified by Treaty or otherwise recognised at international level that subsequently becomes a Member;
 - (c) if the Territory of the Member does not have a National Olympic Committee and an athlete qualifies to compete at the Olympic Games for the Territory's parent Country. In such a case, the athlete's representation of the Territory's parent Country at the Olympic Games shall not affect his eligibility to continue to compete for the relevant Member Territory in other International Competitions under Rules 1.1(a), (b), (c), (f) or (g).
5. In accordance with Rule 21.2, the eligibility of an athlete competing under these Rules shall at all times be guaranteed by the Member to which the athlete is affiliated. The burden of proof in establishing whether an athlete is eligible in accordance with this Rule 5 rests with the Member and the athlete concerned. The Member must provide the IAAF with valid / authentic documentation demonstrating the athlete's eligibility and such other evidence as may be necessary to prove the athlete's eligibility on a definitive basis. If required by the IAAF, Members shall provide a certified copy of all documentation on which it seeks to rely in demonstrating the athlete's eligibility under this Rule.
6. This Rule 5 does not apply to Neutral Athletes.

RULE 6 PAYMENTS TO ATHLETES

Athletics is an open sport and, subject to the Rules and Regulations, athletes may be paid in cash or in kind in any way appropriate for appearing, participating or performing in any athletics competition or engaging in any other commercial activity related to their participation in Athletics.

RULE 7 ATHLETES' REPRESENTATIVES

1. Athletes may use the services of an Athletes' Representative to assist them in the negotiation of their athletics programme and in such other matters as they may agree. Alternatively, athletes may negotiate their own Athletics programmes.
2. Athletes in the IAAF Top-30 List in a standard event as of the end of a calendar year shall not, during the following year, enter into or extend an agreement to use any person in respect of the above services who is not an Athletes' Representative.
3. Members, acting reasonably, shall be responsible for the authorisation and recognition of Athletes' Representatives. Each Member shall have jurisdiction over Athletes' Representatives acting on behalf of their athletes and over Athletes' Representatives acting within their Country or Territory or over Athletes' Representatives who are nationals of their Country.
4. To assist Members in this task, the Council shall publish Regulations governing Athletes' Representatives. The Athletes' Representative Regulations shall provide for mandatory requirements to be included in each Member's regulations governing Athletes' Representatives.
5. It is a condition of Membership that each Member includes a provision in its constitution that all agreements between an athlete and an Athletes' Representative shall comply with the Rules and the Athletes' Representative Regulations.
6. An Athletes' Representative shall have integrity and good reputation. If required to do so, he shall demonstrate sufficient education and knowledge for the activity of Athletes' Representative by successfully completing an examination established and organised in accordance with the Athletes' Representative Regulations.

7. Each Member shall annually provide to the IAAF a list of all Athletes' Representatives that it has authorised or recognised. The IAAF shall annually publish an official list of all Athletes' Representatives.
8. Any athlete or Athletes' Representative who does not comply with the Rules and Regulations, may be subject to sanctions in accordance with the Rules and Regulations.

RULE 7 S 1 UKA SUPPLEMENT ATHLETES' REPRESENTATIVES

An athletes' representative is any individual who advises or assists athletes in the planning, arranging and negotiation of their athletic programme.

- (1) UK Athletics shall authorise, register and have jurisdiction over all Athletes' Representatives acting within its territory, under the terms of IAAF Rule 7, together with any Regulations and Guidelines published by UKA. UK Athletics will only authorise individuals to be Athletes' Representatives.
- (2) No athlete is permitted to use the services of any Athletes' Representative not authorised by UKA and any athlete who does so may be subject to sanctions in accordance with UKA and/or IAAF Rules together with any Regulations made there under. Athletes' Representatives require authorisation from UKA when acting as an Athletes' Representative in relation to any athlete, whether or not the athlete concerned is subject to the jurisdiction of UKA or competing within the United Kingdom.
- (3) UK Athletics shall establish such procedures as it thinks fit for the authorisation and regulation of Athletes' Representatives. UKA shall be empowered to withdraw, cancel or suspend the authorisation of any Athletes' Representative and all authorised Athletes' Representatives shall comply with such direction(s) that UKA may issue from time to time.
- (4) Athletes may use the services of any authorised Athletes' Representative with the prior consent of UKA but no such consent shall be granted and no Athletes' Representative shall receive authorisation unless a contract exists between the athlete

and his/her Representative which contains the minimum terms set out in the Guidance Notes issued both by the IAAF and UKA referred to in paragraph Rule 7 S1(2) above.

RULE 8 ADVERTISING AND DISPLAYS DURING INTERNATIONAL COMPETITIONS

1. Advertising and displays of a promotional nature shall be permitted in all International Competitions as specified in Rule 1.2(c), provided such advertising and displays comply with the terms of this Rule and with any Regulations that may be passed hereunder.
2. The Council may pass Regulations from time to time giving detailed guidance as to the form advertising may take and the manner in which promotional or other material may be displayed at International Competitions conducted under these Rules. These Regulations shall adhere to at least the following principles:
 - (a) Only advertising of a commercial or charitable nature shall be allowed at competitions conducted under these Rules. No advertising which has as its objective the advancement of any political cause or the interests of any pressure group, whether domestic or international, shall be allowed.
 - (b) No advertising may appear which, in the opinion of the IAAF, is tasteless, distracting, offensive, defamatory or unsuitable bearing in mind the nature of the event. No advertising may appear which obscures, either partially or otherwise, the television camera's view of a competition. All advertising must comply with any applicable safety regulations.
 - (c) The advertising of tobacco products is prohibited. The advertising of alcohol products is prohibited, unless expressly permitted by the Council.
3. The Regulations under this Rule may be amended by the Council at any time.

RULE 8 S 1 UKA SUPPLEMENT ADVERTISING AND SPONSORSHIP

See the UKA Supplements in Rule 143 for conditions applying to clothing, advertising and sponsorship.

ELIGIBILITY

RULE 20 DEFINITION OF ELIGIBLE ATHLETE

An athlete is eligible to compete if he agrees to abide by the Rules and has not been declared ineligible.

RULE 21 RESTRICTION OF COMPETITION TO ELIGIBLE ATHLETES

RULE 21 S 1 UKA SUPPLEMENT ELIGIBILITY TO COMPETE

Eligible Athletes

- (i) All competitions under the rules of UKA and Domestic Competitions held under IAAF Rules are confined to eligible athletes as defined by these rules. All athletes in Age Groups covered by these Rules (Age Group Under 13 upwards) must be registered with their National Association and comply with their terms and conditions including payment.
- (ii) Should the Competitor not be registered they will be liable to disqualification and in such a case the competition shall be decided as if the ineligible competitor had not taken part. In an Inter-Club or Inter-Team competition that disqualification does not necessarily disqualify the Club concerned.
- (iii) Any protest in respect of the registration of an athlete must be made within 5 working days from the formal declaration of issuing the result of the competition.
- (iv) To aid the registration process:
 - (a) Athletes being registered with their National Association for the first time will have the provision of one week's grace to enable clubs to register their athletes retrospectively beyond the athletes' participation in a competition in which they have taken.
 - (b) In addition Home Country Associations may give relaxation in part or whole to the above regulations, in their absolute authority, through the meeting licence (normally for Track and Field events this would relate to

Level 1 meetings but in exceptional circumstances also to Level 2 meetings).

- (v) Registration payment arrangements are at the discretion of the Home Countries.
- (vi) Unattached athletes and any Club Member participating as an individual and not as a Member of any Club Team, competing in Road Walking, Road Running, Fell, Hill and Mountain Running and Trail Running are excluded from these regulations.

RULE 21 S 2 UKA SUPPLEMENT CLUBS

- (1) Each Club and Competition Provider must be affiliated either to UKA for UK wide Competitions or to the National Association in whose geographical area of responsibility the Club's headquarters are located.
- (2) An affiliated Club or Competition Provider must supply to the Association to which it is affiliated, and to the UKA itself, such information as that body requires.
- (3) A Club must be properly constituted with a constitution which provides, inter alia, for its democratic management by means of a managing committee and the holding of an annual general meeting of all its members.
- (4) Athletics is organised within the following disciplines:
 - (i) Track and Field
 - (ii) Race Walking
 - (iii) Cross Country
 - (iv) Road Running
 - (v) Fell, Hill and Mountain Running
 - (vi) Trail Running
- (5) A club may only compete in Open Team Competitions if that Club is specifically affiliated for that discipline (not applicable to Trail Running).

RULE 21 S 3 UKA SUPPLEMENT CLUB MEMBERSHIP

Types

(1) **First Claim Club Member**

- (i) The First Club joined by athletes will be known as their First Claim Club and such athletes are defined as a **First Claim member**. This status will remain in place until they give notice that they wish to terminate their membership of that Club. Such termination shall only be effective once all outstanding tangible assets of the former Club held by the athlete have been returned. If athletes wish to commence membership of a new First Claim Club then they must comply with the requirements set out in paragraphs (8) to (10) below.
- (ii) Once athletes have represented a Club in any Competition they are ineligible to compete for another Club in Open Team Competition immediately after resignation from that Club and until the transfer process to that Club has been completed in accordance with these Rules. For the avoidance of doubt, an athlete may compete as an individual during that period of ineligibility from team competition once their resignation and new membership have been accepted by both the respective Clubs.

(2) **Other Discipline First Claim Club Member:** Where a Club has not registered that Club for Open Team Competition in a particular discipline as set out in Rule 21 S2(4) above then that athlete may join another Club for First Claim Open Team Competition solely for the purpose of competition in that discipline. Should an athlete wish to register for this membership they must first complete the appropriate “Other Discipline Form” available from the National Associations and have that application confirmed by that Association.

(3) **Second Claim Club Member:** In addition to an athlete having a First Claim Club as defined in (1) above they are permitted to become a member of a Second Claim Club. Whilst this may be for social, coaching or other reasons that athlete may compete for that Club in competitions which specifically state in its rules that its

competition is open to **Second Claim members**. Such an athlete is hereafter defined as a Second Claim member. Any affiliated Club accepting a Second Claim or First Claim other member as a competing athlete must satisfy themselves that the athlete is already registered with their National Association.

- (4) **Higher Competition Club Member (HCA): This category only applies to Senior and Under 20** Track and Field athletes who may apply for registration to compete for a ‘Higher Competition Club’ in **Senior Track and Field league competitions only**. The application, which shall be made to UKA, must be accompanied by the requisite fee which will be determined annually by the Board of UK Athletics, but a fee shall only be payable for the first two years of registration. The application will require approval and endorsement by UKA and once approved the athlete will be deemed to be a HCA member of that Club

All applications must be received by UK Athletics on or before 1st March in the year of competition and will be effective for that calendar year only. Such application will only be accepted from athletes who, at the time of registration, are eligible to compete for their First Claim Club in open team competition. The registration will take effect from 1st April of the year in question. The registration must be renewed with the same or another Club for each and every year that the athlete wishes to benefit from such higher level competition.

Three tiers of league competition are recognised:

- (i) UK level (British Athletics League; UK Women’s Athletics League)
- (ii) Northern Irish; Scottish; Welsh; Midland; Northern and Southern Leagues
- (iii) Other Lower Level Leagues

Athletes may only join the ‘Higher Competition Club’ if their own First Claim club does not, in that season, compete in that league. Athletes may, at their discretion, decide whether to compete for their Higher Competition Club or their First Claim Club on any one day but not for both.

Process of becoming a member of a club, transferring clubs and resignation

- (5) **Membership of a Club**, whether under (1), (2) or (3) above commences on the actual day of election by the Committee of that Club at a properly convened meeting.
- (6) **“Unattached”**: An athlete who is not a member of an affiliated Club shall be regarded as ‘unattached’. After one year of competition an athlete taking part in any event within disciplines listed in Rule 21 S2(4) (i) and (iii) must be a member of a Club affiliated to UKA and be registered with a National Association. Once an athlete has been registered with a National Association then it is not possible to return to “unattached” status. For the avoidance of doubt, this condition does not apply to athletes who participate solely in Road Walking, Road, Fell, Hill and Mountain or Trail events.
- (7) **Communication**: All communications between clubs or by athletes or clubs with UKA or National Associations may be either by letter or by electronic communication
- (8) **Transfer from one club to another**: Athletes desiring to change their First Claim Club must complete the form approved by UKA in every detail and submit it to the Home Country Eligibility Committee in which the headquarters of the Club they now wish to represent is located. This application must be accompanied by an administration fee of £10. (This fee is waived for athletes who are in the Under 13 or Under 15 age groups at the time of receipt of the application, although the necessary form needs to be completed and submitted to the relevant Eligibility Committee to register the change of first claim status)

An athlete who has taken part in any competition and / or has been registered at any time with a National Association must complete the change of club process as set out above. Former club members whose membership has lapsed by not paying a club fee, not being registered with a National Association or having not competed as a member of that club) for a period of 3 years from the date their membership lapsed may apply to join a different club on the basis that their previous membership has lapsed and the administration

fee will not be payable.

Provided that the applicant has not made a successful application for change of first claim status within a twelve month period and the completed application form and administration fee are received by the appropriate Eligibility Committee by the 10th day of the month, the change of first claim status, subject to the succeeding paragraph, will be operative from the 1st day of the following month. Applications received after the 10th of the month will not be reviewed until the following month and the change of first claim status will be operative from the first day of the month following acceptance.

Where an online eligibility transfer process is operated, the resignation is accepted unconditionally by the athlete's First Claim Club, no disputes or issues are identified and all interested parties agree, the athlete may be granted immediate clearance to compete as a First Claim Member of their new Club. Notification of clearance will be made to all affected Clubs. In all other cases the conditions expressed in the previous paragraph will apply.

Any athlete making a false declaration in support of such an application will be subject to at least a waiting period as outlined in (9) below and may be subject to more severe penalties.

- (9) If an athlete makes a second or subsequent application to change their first claim status within a twelve month period then the process of applying is as outlined in 21 S8. If the application is in order and submitted by the 10th of the month then clearance will become operative on the first day of the fourth month following that acceptance.
- (10) An athlete wishing to claim partial or complete exemption from the imposition of the four month waiting period may make application to the National Eligibility Committee in the manner identified in (8) above.
- (11) **Resignation from a Club:** A notice of resignation from a Club must be made in writing by the athlete, or by a parent/guardian of an athlete under the age of 16, and shall be determined by the Club Committee within one calendar month of receipt. In default the appropriate National Eligibility committee shall determine that

resignation. Membership shall be deemed to have ceased on the actual date of submitting the resignation, (but see restriction identified in (1) above). Members wishing to join another Club following resignation must comply with the conditions within (8 - 10) above as applicable. After 28 days from ceasing to be a member of a Club or Association, having competed in disciplines listed in Rule 21 S2(4) (i), (ii) or (iii), athletes shall not be eligible to compete in Open Competition until they have again become members of an affiliated Club or Association.

- (12) **Amalgamation or Absorption of a Club:** In the case of a Club amalgamated with, or absorbed by, another Club membership shall be regarded as continuous. If, however, members on receiving notice of the amalgamation or absorption of the Club, shall within 28 days notify in writing the Secretary of the Club, or other persons issuing such notice that they do not intend to continue in membership, such membership shall be regarded as having ceased on the date of amalgamation or absorption. The position of the athlete in regard to Open Team Competition shall be the same as if the original Club had been disbanded.
- (13) **Membership arrangements where a Club is disbanded:** Athletes whose former Club has been officially disbanded may seek approval from the appropriate Eligibility Committee to represent another Club in Open Team Competition with effect from the first day of the following month.
- (14) **Expulsion from Membership from an Affiliated Club:** The Management Committee of an affiliated Club shall have the power to expel any member whose membership is twelve months in arrears, provided that a month's notice in writing shall have been sent to the member's last known address giving information of the proposed action of the Committee.
- (15) **Disputes between Athletes and their Clubs** relative to competition matters may be referred to the appropriate National Association Eligibility Committee for arbitration under its appeal procedure.
- (16) **Expulsion from Membership by UKA:**
- (i) In its consideration of matters referred to it by National Associations or Appeals received in accordance with Rule 146 S1, UKA may deem that the conduct of a member of an

Affiliated club in relation to any competition matter is sufficiently serious to demand that the affiliated club concerned expel that person from club membership in perpetuity or for such period of time that UKA may determine, including when that person:

- (a) has committed a serious criminal act
 - (b) is guilty of a serious breach of an anti-doping rule
 - (c) is guilty of a fundamental breach of UKA licensing conditions
- (ii) The above clause will also relate to any club member who is an Official, Coach or athlete support personnel considered to have offended under 16(i) above. Such expulsion to extend also to the removal of an Official or Coach UKA Licence.
- (iii) An affiliated Club which refuses to sanction the exclusion of such a person in turn renders itself liable to expulsion from membership of UK Athletics, as does any other affiliated Club which allows the person concerned to become a member or to become associated with any of the Club's activities.

RULE 21 S 4 UKA SUPPLEMENT COMPETITION CONDITIONS

- (1) **Birth qualification:** For the purpose of determining place of birth for a competition qualification this may be either at the location of actual birth or at the domicile of the mother at the time of birth, if different. In the event that the different locations are in different Counties or Districts then the athletes may make an irrevocable selection for which County or District they wish to be eligible. Once an athlete has made a decision as to their County or District of birth this may not be changed.
- (2) **Individual Open Competition:** An Open Competition is one which is open to all athletes who have registered with their National Association. The Association/ Competition Provider may define a particular geographical location and/or age group. Exemptions apply to Road, Hill and Fell and Trail races
- (3) **Open Team Competition:** Open Team Competitions are competitions open to all eligible Clubs affiliated for that discipline,

including all Clubs in a particular County, District and/or age group.

Only First Claim Members and Other Discipline First Claim Members of a Club may represent that Club in Open Team Competition unless the Competition Provider has stipulated that such competition is also open to Second Claim Members and Higher Competition Members as defined in 21 S3 and S4.

The Competition Providers of such competitions or races may make such qualifying conditions as they think fit, including the right to stipulate in Senior Track and Field League Competition that they shall be for First Claim and Higher Competition Club members only, but not at the exclusion of either. Notwithstanding the above, Senior Track and Field League Organisation rules may limit the number of Higher Competition Athletes allowed to compete per Club in any one fixture. This number must be at least two per Club. The rules of specific Leagues may permit a larger number to compete. Higher Competition Club members competing under these rules shall not have their points disallowed from their club's score because of their status as Higher Competition Club members unless the maximum allowed has been exceeded.

There is no restriction to the total number of Higher Competition Members that a club may have registered at any one time.

- (4) **Composite Teams:** Clubs may apply to UKA to become a Composite Team where from 2 to 5 Clubs wish to combine together for specific competitions. UK Athletics will approve such registration if it complies with application guidelines. Approved registrations will be forwarded to the relevant Competition Provider who may accept or reject such an application. Requests for the registration of a Composite Team must be received by UK Athletics no later than 30th September of the preceding year and be accompanied by the relevant fee which will be determined annually by the Board of UK Athletics. The Competition Advisory Group may agree, at their sole discretion, to vary these conditions.

NOTE: Such an amalgamation of teams for competition purposes specifically does not require the Constitution of the Clubs concerned to be amalgamated.

- (5) **Jurisdiction:** Every Competition Provider of an athletics meeting or competition under UKA rules, and every person tendering an entry for such meeting or competitions shall be considered to have submitted to the jurisdiction of UKA on all questions which may arise concerning the application, construction, meaning or effect of the rules of UKA.
- (6) **Additional Rules & Conditions:** Any Competition Provider may apply additional rules and conditions to those required in UKA rules but must not relax any Rules.
- (7) **Health and Safety:** if the relevant Referee or Medical Officer of a Competition considers that the performance of any athlete may be injurious to their health and safety then that Referee can refuse to allow that athlete to start or continue to compete in a Competition at their sole discretion.

RULE 21 S 5 UKA SUPPLEMENT FIRST CLAIM STATUS

- (1) Where eligibility is not defined in the paragraphs 2 - 5 below, athletes who are registered with their National Association under rule 21 S1 are eligible to represent a Club in Open Team Competition when they join their first Club as a first claim member.
- (2) **Where athletes are at school**, that school shall always have first claim on their services, irrespective of any other claim on them.
- (3) **When at University or Recognised Establishments of Higher Education**
 - (i) Full time students at recognised establishments of Higher Education shall be eligible to compete in Open Team Competition for their College or University provided that their first claim club is not competing in that competition. In the case of a league where there is more than one division, this will be deemed to be the same competition for the purpose of this rule.
 - (ii) An establishment of Higher Education can only invoke the provisions in (1) above if membership of its Club is solely restricted to students and staff of that establishment.

- (4) **Other Discipline Membership:** Where athletes' First Claim Clubs do not affiliate a particular discipline listed in Rule 21 S2(4) above, they are eligible to represent an Other First Claim Club in that discipline of athletics as defined in 3 above for which their First Claim Club does not affiliate, following approval from the appropriate National Eligibility Committee.
- (5) **Foreign Athletes:** Foreign Athletes: Under 20 and Senior athletes who are not eligible to compete for Great Britain and Northern Ireland under IAAF Rules are only permitted to represent a Club in Open Team Competition as a first claim member if they:
- (i) satisfy the criteria for eligible residence set out below, and
 - (ii) have been registered as an eligible foreign athlete with UKA in the year of competition in accordance with the procedures then applied by UKA, or have successfully applied under rule 21 S8 to the appropriate National Eligibility Committee for relaxation of or exemption from the above.

When applying for registration, the athlete must provide as much evidence as may reasonably be required in order to demonstrate their eligible residence and will be required to pay a registration fee in an amount from time to time determined by the Board of U.K. Athletics. Application must be made to renew registration annually, but a fee shall only be payable for the first two years of registration. Should an athlete change their IAAF eligibility during the year from GB & NI to another Country (except as set out in the "Note" below) an application under this rule to register as an eligible foreign athlete is required and have that approved under this rule before they are eligible to resume Open Team Competition for their first claim club.

An athlete shall satisfy the criteria for eligible residence for the purposes of these Rules if they:

- (iii) have been continuously resident in the U.K. for a period of at least 4 weeks and
- (iv) their presence would not reasonably be regarded as temporary.

For these purposes, presence shall be regarded as temporary, irrespective of the intended length of stay, if the primary purpose of that presence would reasonably be considered to be for any of the following: holidays, attending sports training or competition, visiting family members and work and educational visits, Provided that presence for the purposes of performing an employment contract or a formal course of education, in each case for a continuous period of at least 3 months, shall not be regarded as temporary.

Competition Providers may choose to apply more restrictive restrictions as allowed in 21 S4(6) Additional Rules & Conditions above.

When registered as an eligible Foreign Athlete, the registration may be revoked (with retrospective effect) if false information has been provided during the application process or the athlete's situation changes and the relevant Eligibility Committee deems that the athlete no longer satisfies the criteria for eligible residence.

NOTE: Athletes possessing dual nationality of Great Britain and Northern Ireland and another country recognised by the IAAF will be regarded as eligible to seek to represent any Club under the jurisdiction of UKA unless they represent that other country in international competition when they will henceforth be regarded as an athlete governed by this Rule and will need to seek registration for subsequent seasons. Athletes born in Northern Ireland and resident within the United Kingdom are exempt from the requirement to register even if they have represented the Republic of Ireland in international competition.

RULE 21 S 6 UKA SUPPLEMENT COUNTY, DISTRICT AND AREA QUALIFICATIONS

(1) English County Qualification

- (i) County Championships are open to all eligible athletes possessing a County qualification.
- (ii) A County qualification may be acquired as follows:
 - (a) By birth (see also Rule 21 S4(1))

- (b) By nine month's continuous bona fide residence in the County immediately prior to the competition.
- (c) By service in a Unit of HM Forces stationed in the County for nine months immediately prior to the date of the competition. Temporary absence on duty shall not break a qualification acquired under this paragraph.

NOTE: Membership of a Club affiliated to a County Association does not, of itself, provide an athlete with a County qualification unless at least one of (a) – (c) is above is satisfied.

- (iii) Competitors who have qualified and competed, under (1)(ii)(b) or (c) above retain that qualification until they have acquired a residential qualification and competed in the Championship of another County, or represented another County in an Inter-County Championship.
- (iv) A student at school, college or university does not acquire a residential qualification by residence in the County during term time only (See also (x) below)
- (v) An athlete who has competed in a County Championship (other than is allowed under (x) below) or represented a County in an Inter-County competition, may not compete in the Championships of, nor represent, another County in that Competition Year.
- (vi) County Inter-Team (including relay) Championships are open to:
 - (a) Any Club affiliated to the County Association, fulfilling the appropriate requirements of Rule 21 S2(4)
 - (b) Any Unit of HM Forces stationed in the County
 - (c) Any school, college or business house in the County

NOTE: Every member of a team must hold a County qualification for that event as defined in (ii) above.

- (vii) A County may at its discretion limit Team Championships to affiliated Clubs.
- (viii) Athletes whose first claim Club is not affiliated to the County Association may compete for their second claim Club in a County Inter-Team Championship if they possess the necessary County qualification.
- (ix) A Club may affiliate to more than one County.

- (x) A County may at its discretion relax the qualification in the case of athletes in term-time residence at a school, college or university within its boundaries, but competition in any such events shall not be deemed to have established a County qualification for any inter-county competition. This discretion is not extended to include athletes of any age attending only as day students at the institution concerned.
- (xi) Where County boundaries are changed by law, affecting the place of birth or residence of an athlete, thereby moving it from County A to County B the following shall apply:
- (a) if athletes have already competed for County A, or in the Championships of County A, under (ii) above, they shall retain the existing birth or residential qualification unless notice is given in writing to the Honorary Secretary of County A that they wish henceforth to be qualified for County B.
- (b) if athletes have not competed for County A or in the Championship of County A under (ii) above, the place of birth shall be deemed to have been in County B and any period of residence in County A to have been in County B.
- (xii) Competitors in an Inter-County Championship must possess a County qualification under (ii) above for the County they represent.

(2) English Area Championships and Representation

- (i) Individual competition
- (a) An Area qualification to compete shall be acquired as follows:
- By birth (See also Rule 21 S4(1))
 - By nine months' continuous bona fide residence within the Area boundary immediately prior to the date of competition.
 - By nine months' service in HM Forces stationed within the Area boundary immediately prior to the date of the competition.
- (b) A student at school, college or university does not acquire

a residential qualification by residence during term time alone. An Area, though, may, at its discretion, relax the residential qualification in the case of Under 20 and younger athletes, and of Seniors in residence at college or university, but any competition shall not be deemed to have established an Area qualification.

- (c) No athlete is allowed to compete in the Championships of more than one Area Association in any one nine month period.

(3) Team Competition

Area Competition: eligibility to compete shall be by first claim membership of a Club affiliated to that Area.

(4) Area Representation

Athletes may compete for an Area provided they are eligible to compete in that Area's Championships as defined in 2(i) (a) above

(5) Scottish District Championships

- (i) A District qualification shall be acquired as follows:
 - (a) By birth.
 - (b) By residence in the District.
 - (c) By first claim membership of an affiliated Club with its headquarters within the District boundary.
- (ii) Athletes may only compete at District Championships within one District in any six month period (commencing 1st April and 1st October)

(6) Welsh Regional Championships

- (i) A Regional qualification may be acquired:
 - (a) By birth.
 - (b) By nine month's continuous bona fide residence in the Region
 - (c) By attendance at a school, college or university in the Region

NOTE: Students qualified under (c) above do not acquire qualification to participate in UK Inter-County competitions.

- (ii) An athlete who has competed in a Regional Championship or represented a Region in an inter-regional event may not compete in the championships of, nor represent another region, in the same year of competition.

RULE 21 S 7 UKA SUPPLEMENT HOME COUNTRY CHAMPIONSHIPS AND CLOSED CHAMPIONSHIP QUALIFICATIONS

(1) Home Country Closed Championship Qualifications

Qualification to compete in a closed Home Country Championship shall be as identified in (2) below.

NOTE 1: Athletes who have competed for one Home Country may only subsequently compete for another Home Country or at a closed Home Country Championship after a period of at least one year from their last representation for the previous Home Country, unless varied by agreement between both of the Home Countries involved.

NOTE 2: Athletes must be both a member of Club affiliated directly or indirectly to UKA, and registered as an individual with a National Association in order to compete in national championships.

(2) Home Country Representation

Qualification to compete for a Home Country in competitions within the United Kingdom shall be acquired:-

- (i) by birth in the respective Home Country
- (ii) by birth of one or both parents in the respective Home Country
- (iii) by two year's continuous bona fide residence in the respective Home Country immediately prior to the date of the competition concerned.

NOTE 1: Having qualified under (c) above and competed for a Home Country at full Senior International level, such qualification may continue until the athlete qualifies and competes for another Home Country Association,

NOTE 2: A student at school, college or university does not thereby acquire a residential qualification by residence during term time alone.

RULE 21 S 8 UKA SUPPLEMENT ELIGIBILITY AND EXEMPTION APPLICATIONS

- (1) Each National Association shall appoint a Committee consisting of not fewer than five members which shall be called the Eligibility Committee. The Committee shall be responsible for deciding all matters relating to eligibility, including all first claims issues.
- (2) The Eligibility Committee shall have the powers:
in any case where it considers that the general welfare of athletes or athletics will be best served, to make an exception to the eligibility rules. They may grant exemption, either wholly or in part to these Rules.

For the avoidance of doubt issues arising in respect of Composite Teams, Foreign Athletes and Higher Competition Athletes will be dealt with by the UKA Eligibility Committee defined in (4) below.

Guidelines for considering claims for relaxation or exemption may include:-

- (i) Where the change of Club is related to a genuine and significant change of residence. Such grounds are only considered if the application is made within twelve months of the change of residence provided that the new Club is nearer to the new residence. Or
 - (ii) Where the original Club is unable to provide the athlete with adequate competition or facilities, or
 - (iii) Where the Club from which the athlete has resigned gives its written support to the move. Such exemption, in whole or in part, may be granted on one occasion only, or
 - (iv) Where a specific welfare issue affects the ability of athletes to compete for their original Club.
 - (v) Where an application for registration as a Foreign Athlete is received at any time other than as defined in Rule 21 S5(5).
- (3) All applications for relaxation or exemption from the operation of any of the Rules must be accompanied by a fee of £10 to the relevant National Association, which may be refunded at the discretion of the Committee.
 - (4) **Appeals:** In the event that an athlete or a Club is dissatisfied with the decision of the Eligibility Committee they shall write to the Chief Executive of UK Athletics, together with a fee of £30 and complete documentary evidence for the application for exemption. The Chief Executive will immediately pass the papers to the UKA

Eligibility Group (comprising Chair appointed by UKA, one member from each National Association Eligibility committee, and the members of the appeal panel together with ex-officio the leading member of UKA staff responsible for Eligibility within UKA and the leading member of England Athletics who acts as UKA's Agent in managing the eligibility processes on behalf of UKA). The Chair of the UKA Eligibility Group will convene the Appeal Panel comprising three members of the Group who are not members of the Clubs involved, who will consider and determine the Appeal within four weeks of receipt of the Appeal. The decision of the panel will be final and binding. A refund of the application fee may be made at the discretion of UKA. No new evidence will be accepted by UKA that has not been submitted to the Association concerned [unless so agreed by the Appeal Panel]

RULE 21 S 9 UKA SUPPLEMENT OPEN TEAM COMPETITION

- (1) Generally in any Open Relay Race Clubs shall not be allowed to enter more than three times the number entitled to compete. A Club entering more than one team in a race shall be allowed to select their teams from the Club entry for that event, but no athlete may compete for more than one team. Teams must be declared before the start of the race.
- (2) Ineligibility of a competitor in an Inter-Club or Inter-Team competition does not necessarily disqualify the Club concerned and in such a case the competition shall be decided as if the ineligible competitor had not taken part.
- (3) No athletes shall be allowed to compete in a team unless their names have been declared prior to the event. If it is impracticable to issue a programme a complete list of the entries should be provided for the Referee.
- (4) Track & Field**
 - (i) In any Open Team Race Clubs shall not be allowed to enter more than twice the number entitled to compete.
 - (ii) A Club entering more than one team in a race shall be allowed to select their teams from the Club entry for that event.
 - (iii) Competition Providers must specify, prior to the event, whether Clubs are to declare their teams before the start of the race.

- (iv) At the discretion of the Referee a team may be permitted to start fewer competitors than the minimum number required to score.
- (v) Stations shall be drawn and the members of each team shall, if necessary, be lined up behind each other at the start of the race.
- (vi) The team scoring the least number of points, according to the positions in which the members of the team finish whose positions are to count, shall be the winner; the positions of the non-scoring members of a team, whether it finishes all its members or not, shall be scored in computing the totals of the other teams. In the event of a tie on points, the team whose last scoring member finishes nearest first place shall determine the result.
- (vii) Alternatively, team position may be decided on the aggregate time of the scoring members of the team, the team having the lowest aggregate being the winner. Time aggregates shall only be used if the Competition Provider has announced in advance that this method will be used.
- (viii) In the case of a tie between two or more individual competitors each shall score for the team a number of points obtained by dividing the total sum of their position numbers, reckoned as if they had, instead of being tied, finished regularly in a file, by the number of such competitors. (Thus, for instance, if two competitors finish tied for second place, each of them shall score $2\frac{1}{2}$ points).

(5) Cross Country

Unless otherwise specified by the Competition Provider, the team scoring the least number of points, according to the positions in which the members of the team finish whose positions are to count, shall be the winner; the positions of the non-scoring members of a team, whether it finishes all of its members or not, shall be scored in computing the totals of the other teams. In the event of a tie on points, the team whose last scoring member finishes nearest first place shall determine the result.

In cross country relay races where a team includes a runner who has already run a stage of the race, that team shall not, subject to the

entry conditions of the race, be included in the official results.

(6) Road Races

- (i) Competition Providers must specify, prior to the event, whether Clubs are to declare their teams prior to the start of the race.
- (ii) Competition Providers may nominate a time before which all team declarations must be submitted.
- (iii) Team positions in road race team competitions may be decided by the total achieved by adding the times of all scoring members together, the team with the lowest aggregate time taking precedence. Alternatively the competition may be decided according to the finishing positions of the scoring members of the team.

The team scoring the least number of points, according to the positions in which the members of the team finish whose positions are to count, shall be the winner; the positions of the non-scoring members of a team, whether it finishes all of its members or not, shall be scored in computing the totals of the other teams. In the event of a tie on points, the team whose last scoring member finishes nearest first place shall determine the result.

- (iv) All teams in a Road Relay must be declared before the start of the race and the stage order of runners specified in the manner laid down by the Competition Provider. No changes may be made in the declared order of running without the prior approval of the Race Referee and the Competition Provider.

(7) Road Relays

Where a team includes a runner who has already run a stage of the race that team shall not, subject to the entry conditions of the race, be included in the official results.

(8) Fell, Hill and Mountain Running

Fell, Hill and Mountain Running Runners may count in team races for their first claim Club only. This Club may be different from their first claim road, cross country or track Club but must comply with Rule 21 S3.

RULE 23 PERSONS SUBJECT TO DECLARATION OF INELIGIBILITY

Any athlete, Athlete Support Personnel or other person:

- (a) who takes part in an athletics competition or event in which any of the competitors were, to his knowledge, suspended from participation or ineligible to compete under these Rules, or which takes place in a Country or Territory of a suspended Member. This does not apply to any athletics competition which is restricted to the Masters' age group (in accordance with Rule 141);
- (a) who takes part in any athletics competition which is not authorised in accordance with Rule 2 (Authorisation to Stage Competitions);
- (b) who contravenes Rule 4 (Requirements to Compete in International Competitions) or any Regulations made thereunder;
- (c) who contravenes Rule 5 (Eligibility to Represent a Member) or any Regulations made thereunder;
- (d) who contravenes Rule 6 (Payments to Athletes) or any Regulations made thereunder;
- (e) who contravenes Rule 7 (Athletes' Representatives) or any Regulations made thereunder;
- (f) who contravenes Rule 8 (Advertising and Displays during International Competitions) or any Regulations made thereunder;
- (g) who commits a breach of any other Rule (other than as set out in Rule 60.2)

may be declared ineligible under this Rule 23.

RULE 23 S 1 UKA SUPPLEMENT INELIGIBILITY TO COMPETE

The following are ineligible to take part in Competition under UKA Rules: Any person who:

- (i) is not registered with their National Association and conformed with their requirements as set out in Rule 21 S1(1) above.
- (ii) is ineligible to compete in competitions under the jurisdiction of any National Governing Body of athletics affiliated to the IAAF.
- (iii) takes part in any athletics meeting which requires to be sanctioned but has not been permitted / licensed by UKA or other appropriate Association.
- (iv) has been declared ineligible to compete by the IAAF.
- (v) has committed any acts or made any statements either verbally or in writing, or has been responsible for any breaches of the Rules, or other conduct which, in the opinion of a National Association is considered to be insulting, improper or likely to bring the sport and/or UK Athletics into disrepute.
- (vi) Unless the period of ineligibility is stated in the relevant Rule or Regulation of the IAAF or UK Athletics, those ineligible under this Rule shall be deemed ineligible for a period set down in guidelines produced by the Board of UK Athletics, or, in the absence of such guidelines, for such period as the Board of UK Athletics (for doping matters) or the National Association (for all non-doping matters) shall decide.
- (vii) If athletes compete whilst suspended or ineligible, the period of this ineligibility shall be deemed to recommence from the time they last competed as though no part of a period of suspension or ineligibility had been served.

ANTI-DOPING AND BETTING

RULE 30 S 1 UKA SUPPLEMENT ANTI-DOPING

Doping by anyone under the jurisdiction of the UKA Anti-Doping rules, whether committed in or out of competition, is strictly forbidden and is an offence. The full UKA Anti-Doping Rules, including details of the various anti-doping rule offences and the sanctions, along with other relevant information about the UKA “Clean Athletics” programme, can be found at www.uka.org.uk/cleanathletics/. The UKA Anti-Doping Rules, which may be amended from time to time, shall be deemed to form part of these Competition Rules as if set out in full in these Rules as so amended.

RULE 60 S 1 UKA SUPPLEMENT BETTING

NOTE: please refer to the IAAF Code of Ethics which can be found at <https://www.iaaf.org/about-iaaf/documents/rules-regulations#regulations> for full information on processes to be adopted in the event of an investigation in the UK.

All betting at the venue of an event is strictly prohibited.

UKA has the jurisdiction to investigate any allegations of misconduct within the terms of this Rule in so far as they apply to competitions permitted or licensed by UKA or one of the National Associations and, if proven, may apply appropriate sanctions within the terms contained in UKA Supplements to these Rules.

Upon request by the UKA Anti-Corruption Officer or the UKA Chief Executive Officer, a person subject of the Code shall cooperate fully, accurately and promptly with and shall provide all necessary assistance to the UKA Anti-Corruption Officer with respect to any matter pursuant to this regulation (including answering the questions of and furnishing the Anti-Corruption Officer with, all relevant and/or requested documentation and information).

TECHNICAL RULES

RULE 100 GENERAL

All International Competitions, as defined in Rule 1.1, shall be held under the Rules of the IAAF.

In all competitions, except the World Championships and Olympic Games, events may be held in a different format from that provided under the IAAF Technical Rules, but rules giving more rights to the athletes than they would have obtained applying the actual Rules, may not be applied. These formats shall be decided or authorised by the relevant governing body having the control over the competition.

In the case of mass participation events held outside the stadium, these Rules should normally only be applied in full to those athletes, if any, who are designated as taking part in the elite or other defined section of the races such as age group categories for which there are placings for awards or prizes. Race organisers should outline in the information provided to other athletes which other rules will apply to their participation, particularly those pertaining to their safety.

Note: It is recommended that Members adopt the Rules of the IAAF for the conduct of their own athletics competitions

Whilst these Rules already contemplate some variations from their strictest applications, it is emphasised that competition organisers may go even further in using different formats for competitions - the only restriction being that the athlete may not receive more “rights” in such circumstances. For example it is acceptable to reduce the number of trials in a Field Event or reduce the time allowed for an athlete to take his trial but not to increase either.

With respect to mass participation running and walking events it is prescribed that these Rules shall only be fully applied to any elite component of the event or any other part designated by the organisers where there is a logical reason to do so, e.g. because of significant awards or prizes.

However, race organisers are advised to emphasise in the information provided to all participants the rules and procedures that will apply to the various categories, especially in relation to safety considerations,

particularly when all of part of the race is not closed to traffic. This may for example allow athletes (other than those competing in the elite or other categories to whom Rule 144.3 would apply) to use head or earphones when they are running on a closed course but prohibit their use (or at least recommend against it) for the slower runners when the course is open to traffic.

SECTION I – OFFICIALS

RULE 110 INTERNATIONAL OFFICIALS

At competitions organised under Rules 1.1(a), (b), (c) and (f), the following officials should be appointed internationally:

- (a) Organisational Delegate(s)
- (b) Technical Delegate(s)
- (c) Medical Delegate
- (d) Anti-Doping Delegate
- (e) International Technical Officials
- (f) International Race Walking Judges
- (g) International Road Course Measurer
- (h) International Starter
- (i) International Photo Finish Judge
- (j) Jury of Appeal

The number of officials appointed in each category, how, when and by whom they shall be appointed, shall be indicated in the applicable IAAF (or Area Association) Technical Regulations.

For competitions organised under Rules 1.1(a) and (e), the IAAF may appoint an Advertising Commissioner. For competitions under Rules 1.1(c), (f) and (j), any such appointments will be made by the relevant Area Association, for competitions under Rule 1.1(b) by the relevant body, and for competitions under Rules 1.1(d), (h) and (i), by the relevant Member.

Note (i): The International Officials should wear distinctive attire or insignia.

Note (ii): The international officials in (e) to (i) above may be classified as IAAF Level and Area Level according to the applicable IAAF Policy.

The travelling and accommodation expenses of each individual

appointed by the IAAF or an Area Association under this Rule or under Rule 3.2 shall be paid to the individual according to the relevant regulations.

RULE 111 ORGANISATIONAL DELEGATES

The Organisational Delegates shall maintain close liaison with the Organisers at all times and report regularly to the IAAF (or Area Association or other relevant governing body), and they shall deal as necessary with matters concerning the duties and financial responsibilities of the Organising Member and the Organisers. They shall cooperate with the Technical Delegate(s).

RULE 112 TECHNICAL DELEGATES

The Technical Delegate(s), in conjunction with the Organisers, which shall afford them all necessary help, are responsible for ensuring that all technical arrangements are in complete conformity with the IAAF Technical Rules and the IAAF Track and Field Facilities Manual.

Technical Delegates appointed for competitions other than one day meetings shall:

- (a) ensure the submission to the appropriate body of proposals for the timetable of events and the entry standards.
- (b) approve the list of implements to be used and whether athletes may use their own implements or those provided by a supplier.
- (c) ensure that the applicable Technical Regulations are issued to all competing Members in good time before the competition.
- (d) be responsible for all other technical preparations necessary for the holding of the athletics events.
- (e) control the entries and have the right to reject them for technical reasons or in accordance with the Rule 146.1. (Rejection for reasons other than technical must result from a ruling of the IAAF or appropriate Area Association or other relevant governing body.)
- (f) determine the qualifying standards for the Field Events, and the basis on which the rounds shall be arranged for Track Events.
- (g) cause the seeding and draws for all events to be made in accordance with the Rules and any applicable Technical

Regulations and approve all start lists.

- (h) if requested, chair the Technical Meeting and brief the Technical Officials.
- (i) ensure the submission of written reports in advance of the competition on its preparations and after its conclusion on the execution, including recommendations for future editions.

Technical Delegates appointed for one day meetings shall provide all necessary support and advice to the organisers and ensure the submission of written reports on the execution of the competition.

Specific information is provided in the IAAF Technical Delegates Guidelines which may be downloaded from the IAAF website.

RULE 113 MEDICAL DELEGATE

The Medical Delegate shall:

- (a) have ultimate authority on all medical matters.
- (b) ensure that adequate facilities for medical examination, treatment and emergency care will be available at the venue(s) of the competition, training and Warm-up areas and that medical attention can be provided where athletes are accommodated.
- (c) make examinations and provide medical certificates in accordance with Rule 142.4.
- (d) have the power to order an athlete to withdraw before, or to immediately retire from an event during, competition.

Note (i): The powers under (c) and (d) above may be passed by the Medical Delegate (or where no Medical Delegate is appointed or available) to a medical doctor so designated by the Organisers who should normally be identified by an armband, vest or similar distinctive apparel.

Note (ii): Any athlete withdrawn or retired from a running or walking event under Rule 113(d) shall be shown in the result as DNS and DNF respectively. Any athlete not complying with such an order shall be disqualified from that event.

Note (iii): Any athlete withdrawn or retired from a Field Event under Rule 113(d) shall be shown in the result as DNS if he has not taken any trials. However if he has taken any trials, the results of those trials shall stand and the athlete classified in the result

accordingly. Any athlete not complying with such an order shall be disqualified from any further participation in that event.

Note (iv): Any athlete withdrawn or retired from a Combined Event under Rule 113(d) shall be shown in the result as DNS if he has not attempted to start the first event. However if he has attempted to start the first event Rule 200.10 shall apply. Any athlete not complying with such an order shall be disqualified from further participation in that event.

The health and safety of all participants in the competition is a high priority consideration for the IAAF, other governing bodies and competition organisers. The availability of the expertise of a well-respected and qualified person in the role of Medical Delegate is essential to carry out these key tasks, especially as he (or those authorised by him or the Organisers) amongst other duties has the responsibility to withdraw an athlete from competition if deemed necessary for medical reasons. It is important to note that the power of the Medical Delegate (or a medical doctor acting at his request or in his place) applies to all events.

It is essential that there is a reliable communication system and procedures in place between the Medical Delegate (and those authorised to act in his place), the Technical Delegates and the Competition Director particularly in relation to the duties under (c) and (d) above as these have a direct impact on start lists, results and the management of the competition.

RULE 114 ANTI-DOPING DELEGATE

The Anti-Doping Delegate shall liaise with the Organisers to ensure that suitable facilities are provided for the conduct of doping control. He shall be responsible for all matters relating to doping control.

RULE 115 INTERNATIONAL TECHNICAL OFFICIALS (ITOS)

1. Where ITOs are appointed, the Technical Delegates shall appoint the Chief ITO among the appointed ITOs, if one was not appointed

previously by the relevant body. Whenever possible, the Chief ITO, in conjunction with the Technical Delegates, shall assign at least one ITO for every event on the programme. The ITO shall be the Referee of each event to which he is assigned.

2. In Cross-Country, Road Running, Mountain Running and Trail Running competitions, ITOs, if appointed, shall provide all necessary support to the Organisers. They must be present at all times when an event to which they have been assigned is in progress. They should ensure that the conduct of the competition is in full conformity with the Rules, applicable Technical Regulations and relevant decisions made by the Technical Delegates. The ITO shall be the Referee of each event to which he is assigned.

Specific information is provided in the IAAF ITO Guidelines which may be downloaded from the IAAF website.

RULE 116 INTERNATIONAL RACE WALKING JUDGES (IRWJS)

Race Walking Judges appointed for all Rule 1.1(a) International Competitions must be IAAF Level International Race Walking Judges.

Note: Race Walking Judges appointed for competitions under Rules 1.1(b), (c), (e), (f), (g) and (j) shall be either IAAF Level or Area Level International Race Walking Judges.

RULE 117 INTERNATIONAL ROAD COURSE MEASURER

At competitions organised under Rule 1.1, an International Road Course Measurer shall be appointed to verify the courses where road events are held entirely or partially outside the stadium.

The measurer shall be a member of the IAAF/AIMS Panel of International Road Course Measurers (Grade "A" or "B").

The course should be measured in good time before the competition.

The measurer will check and certify the course if he finds it conforms to the Rules for Road Races (See Rules 240.2, 240.3 and 230.11 and respective Notes). He shall also ensure compliance with Rules 260.20 and 260.21 in case a World Record may be made.

He shall cooperate with the Organisers in the course arrangements and witness the conduct of the race to ensure that the course run by athletes follows the same course that was measured and approved. He shall

furnish an appropriate certificate to the Technical Delegate(s).

RULE 118 INTERNATIONAL STARTER AND INTERNATIONAL PHOTO FINISH JUDGE

At all competitions under Rules 1.1(a), (b), (c) and (f) held in the stadium, an International Starter and an International Photo Finish Judge shall be appointed respectively by IAAF, the relevant Area Association or governing body. The International Starter shall start the races (and undertake any other duties) assigned to him by the Technical Delegate(s) and shall supervise the checking and operation of the Start Information System. The International Photo Finish Judge shall supervise all Photo Finish functions and shall be the Chief Photo Finish Judge. Specific information is provided in the IAAF Starting Guidelines and IAAF Photo Finish Guidelines, which may be downloaded from the IAAF website.

It is noted that whilst the International Photo Finish Judge acts as the Chief Photo Finish Judge at those competitions to which he is appointed and the ITOs act as Referees, there remains a clear division in responsibilities between the International Starter (IS) and the other members of the start team. Whilst the IS takes on all the powers and duties of the Starter when starting any race to which he is allocated, he does not either then or at any other time replace or have the power to override the Start Referee.

RULE 119 JURY OF APPEAL

At all competitions organised under Rules 1.1(a), (b), (c) and (f) a Jury of Appeal, which should normally consist of three, five or seven persons shall be appointed. One of its members shall be the Chairman and another the Secretary. If and when considered as appropriate, the Secretary may be a person not included in the Jury.

In instances where there is an appeal relating to Rule 230, at least one member of the Jury of Appeal shall be an IAAF (or Area) Level International Race Walking Judge.

Members of the Jury of Appeal shall not be present during any deliberations of the Jury concerning any Appeal that affects, directly or

indirectly, an athlete affiliated to his own National Federation. The chair of the Jury shall ask any member implicated by this Rule to withdraw, in the event the Jury member has not already done so. The IAAF or the relevant governing body shall appoint one or more alternate Jury members to substitute for any Jury member(s) who are not able to participate in an Appeal.

Furthermore, a Jury of Appeal should likewise be appointed at other competitions where the organisers deem it desirable or necessary in the interest of the proper conduct of the competitions.

The primary functions of the Jury of Appeal shall be to deal with all appeals under Rule 146, and with any matters arising during the course of the competition which are referred to it for decision.

RULE 120 OFFICIALS OF THE COMPETITION

RULE 120 S 1 UKA SUPPLEMENT OFFICIALS FOR UKA DOMESTIC COMPETITION

Refer to UKA Appendix 3 for descriptions of UKA Technical Officials and Management, and the IAAF Rule Book for full details of IAAF Competition Officials' roles.

The Organisers of a competition shall appoint all officials, subject to the rules of the Member in whose Country the competition is held and, in the case of competitions under Rules 1.1(a), (b), (c) and (f), subject to the rules and procedures of the relevant governing body.

The following list comprises the officials considered necessary for major International Competitions. The Organisers may, however, vary this according to local circumstances.

MANAGEMENT OFFICIALS

- Competition Director (see Rule 121)
- Meeting Manager and an adequate number of assistants (see Rule 122)
- Technical Manager and an adequate number of assistants (see Rule 123)
- Event Presentation Manager (see Rule 124)

COMPETITION OFFICIALS

- Call Room Referee(s)
- Track Events Referee(s)
- Field Events Referee(s)
- Combined Events Referee(s)
- Referee(s) for events outside the stadium
- Video Referee(s)
- Chief Judge and an adequate number of Judges for Track Events (see Rule 126)
- Chief Judge and an adequate number of Judges for each Field Event (see Rule 126)
- Chief Judge, an adequate number of assistants and five Judges for each Track Race Walking Event (see Rule 230)
- Chief Judge, an adequate number of assistants and eight Judges for each Road Race Walking Event (see Rule 230)
- Other Race Walking Competition officials, as necessary, including Recorders, Posting Board operators, etc. (see Rule 230)
- Chief Umpire and an adequate number of Umpires (see Rule 127)
- Chief Timekeeper and an adequate number of Timekeepers (see Rule 128)
- Chief Photo Finish Judge and an adequate number of assistants (see Rules 128 and 165)
- Chief Transponder Timing Judge and an adequate number of assistants (see Rules 128 and 165)
- Start Coordinator and an adequate number of Starters and Recalls (see Rule 129)
- Starter's Assistants (see Rule 130)
- Chief Lap Scorer and an adequate number of Lap Scorers (see Rule 131)
- Competition Secretary and an adequate number of assistants (see Rule 132)
- Technical Information Centre (TIC) Manager and an adequate number of assistants (see Rule 132.5)
- Chief Marshal and an adequate number of Marshals (see Rule 133)
- Wind Gauge Operators (see Rule 134)
- Chief Measurement Judge (Scientific) and an adequate number of assistants (see Rule 135)

- Chief Call Room Judge and an adequate number of Call Room Judges (see Rule 136)
- Advertising Commissioner (see Rule 137)

ADDITIONAL OFFICIALS

- Announcers
- Statisticians
- Doctors
- Stewards for Athletes, Officials and Media

Referees and Chief Judges should wear a distinctive attire or insignia. If deemed necessary, assistants may be appointed. Care should be taken to keep the Field of Play as free from officials and other persons as possible.

The number of officials appointed to a competition should be adequate to ensure the required duties are carried out both correctly and efficiently and also to ensure sufficient rest if the competition is over a long period of time on a single day or on several consecutive days. But care must also be taken not to appoint too many so that the competition area becomes cluttered or obstructed by unnecessary personnel. In more and more competitions, some tasks undertaken by on-field officials are being “replaced” by technology and unless a back-up is logically required, this needs to be taken into account when officials are appointed.

A Note on Safety

Referees and competition officials at athletics events have many important functions, but none is more important than their roles in ensuring the safety of all concerned. The athletics arena can be a dangerous place. Heavy and sharp implements are thrown and pose a hazard to anyone in their path. Athletes running on the track or on runways at high speeds can hurt themselves and anyone with whom they collide. Those competing in jumping events, often land in an unexpected or unintended manner. Weather and other conditions can make athletic competition unsafe either temporarily or for longer periods.

There have been instances of athletes, officials, photographers and others who have been injured (sometimes fatally) in accidents in or near competition and training areas. Many of those injuries could have been

prevented.

Officials must always be mindful of the dangers that are inherent in the sport. They must be alert at all times, and must not allow themselves to be distracted. Regardless of their official position, all officials have the responsibility to do what they can to make the athletics arena a safer place. All officials should think about safety whenever and wherever they are in the competition area, and should intervene when necessary to prevent an accident, when they see conditions or a situation that could lead to one. Ensuring safety is of the utmost importance – even more so than strict compliance with the rules of competition. In the rare event when there is a conflict, the concern for safety must prevail.

RULE 125 REFEREES

1. One (or more) Referee(s), as appropriate, shall be appointed for the Call Room, for Track Events, for Field Events, for Combined Events and for Running and Race Walking Events outside the stadium. When appropriate, one (or more) Video Referee(s) shall also be appointed. A Track Referee appointed to oversee the starts is designated the Start Referee.

The Video Referee(s) shall operate from a Video Review Room, should consult and shall be in communication with the other Referees.

At meetings where sufficient officials are available so that more than one Referee is appointed for the races, it is strongly recommended that one of them is appointed as the Start Referee. To be clear the Start Referee in such circumstances should exercise all the powers of the Referee in relation to the start and is not required to report to or act through any other track Referee when doing so.

However, if only one Referee is appointed to oversee the races of a certain competition, and considering the powers he has, it is strongly recommended that the Referee be positioned in the start area, during each start (at least for those events using a crouch start) to witness any eventual problem that may occur and to take any decision needed to solve it. This will be easier when an IAAF certified start information system is in use. If not, and if the Referee will not have time to place himself in line with the finish line after the start procedure (as in 100m, 100/110m hurdles

and 200m), and foreseeing the possible need for the Referee to decide placings, a good solution may be to have the Start Coordinator (who should have an extensive experience as a starter) being appointed to also act as Start Referee.

2. Referees shall ensure that the Rules and Regulations (and other regulations for each particular competition) are observed. They shall rule on any protest or objection regarding the conduct of the competition and shall decide upon any matters which arise during the competition (including in the Warm-up Area, Call Room and, after the competition, up to and including the Victory Ceremony) and for which provision has not been made in these Rules (or any applicable regulations).

The Referee shall not act as a Judge or Umpire but may take any action or decision according to the Rules based on his own observations and may overrule a decision of a Judge.

Note: For the purpose of this Rule and applicable regulations, including the Advertising Regulations, the Victory Ceremony is concluded when all directly related activities (including photographs, victory laps, crowd interaction, etc.) are completed.

It should be carefully noted that it is not necessary for a Referee to have received a report from a Judge or Umpire in order to make a disqualification. He may act at all times by his own direct observation. The above Note should be interpreted to include all matters which are incidental to or relate to the Victory Ceremony and that the Referee for that event is responsible for them. When Victory Ceremonies are held at a different location or in a different session, common sense should be applied and if necessary another Referee may have to be substituted if it is not practical for the original Referee to manage the situation.

3. The Referees for Track Events and for events outside the stadium shall have jurisdiction to decide placings in a race only when the Judges of the disputed place(s) are unable to arrive at a decision. They shall have no jurisdiction over matters within the responsibilities of the Chief Judge of Race Walking events.

The relevant Track Referee has jurisdiction to decide on any facts related to the starts if he does not agree with the decisions made by the start team except in the cases when it regards an apparent false start indicated by an IAAF certified Start Information System, unless for any reason the Referee determines that the information provided by the System is obviously inaccurate.

The Combined Events Referee shall have jurisdiction over the conduct of the Combined Events competition and over the conduct of the respective individual events within it.

4. The appropriate Referee shall check all final results, shall deal with any disputed points and, in conjunction with the Chief Measurement Judge (Scientific) where appointed, shall supervise the measurements of Record performances. At the conclusion of each event, the result card shall be completed immediately, signed (or otherwise approved) by the appropriate Referee and conveyed to the Competition Secretary.
5. The applicable Referee shall have authority to warn or exclude from competition, any athlete guilty of acting in an unsporting or improper manner or under Rules 144, 162.5, 163.14, 163.15(c), 180.5, 180.19, 230.7(d), 230.10(h) or 240.8(h). Warnings may be indicated to the athlete by showing a yellow card, exclusion by showing a red card. Warnings and exclusions shall be entered on the result card and communicated to the Competition Secretary and to the other Referees.

In disciplinary matters, the Call Room Referee has authority starting from the Warm-up Area up to the competition area. In all other instances, the Referee applicable to the event in which the athlete is or was competing, shall have authority.

The applicable Referee (where practicable after consulting the Competition Director) may warn or remove any other person from the competition area (or other area related to the competition including the Warm-up Area, Call Room and coaches seating) who is acting in an unsporting or improper manner or who is providing assistance to athletes that is not permitted by the Rules.

Note: (i) The Referee may, where the circumstances justify it, exclude an athlete without a warning having been given. (See also Note to Rule 144.2.)

Note: (ii) The Referee for events outside the stadium shall, wherever practicable (e.g. under Rules 144, 230.10 or 240.8), give a warning prior to disqualification. If the Referee's action is contested, Rule 146 will apply.

Note: (iii) When excluding an athlete from competition under this Rule, if the Referee is aware that a yellow card has already been given, he should show a second yellow card followed immediately by a red card.

Note (iv) If a yellow card is given and the Referee is not aware that there is a previous yellow card, it shall, once this is known, have the same consequence as if it was given in association with a red card. The relevant Referee shall take immediate action to inform the athlete or his team of his exclusion.

Six key points are made to provide guidance and clarity in relation to the way in which cards are shown and recorded:

- (1) Yellow and red cards can be given either for disciplinary reasons (refer mostly to Rules 125.5 and 145.2) or for technical infringements in case they are serious enough to be considered unsporting manners (e.g. a serious and clear deliberate obstruction in a race).
- (2) Whilst it is normal and usually expected that a yellow card would have been given before a red card, it is envisaged that in the cases of particularly bad unsporting or improper behaviour a red card can be given immediately. It should be noted that the athlete has in any case the opportunity to appeal such a decision to the Jury of Appeal.
- (3) There will be also some cases in which it is not practical or even logical for a yellow card to have been issued. For example the note to Rule 144.2 specifically allows for an immediate red card if justified in cases covered by Rule 144.3(a) such as pacing in races.
- (4) A similar situation might also follow when a Referee issues a yellow card and the athlete responds in such an inappropriate manner that it is justified to then immediately give a red card. It is not essential for there to be two completely different and distinct in time instances of inappropriate behaviour.

(5) As per Note (iii) in cases where a Referee is aware that the athlete in question has already received a yellow card during the competition and he proposes to issue a red card, the Referee should first show a second yellow card and then the red card. However if a referee does not show the second yellow card, it will not invalidate the issuing of the red card.

(6) In cases where a Referee is not aware of a pre-existing red card, and he shows only a yellow card, once this becomes known the appropriate steps should be taken to disqualify the athlete as soon as possible. Normally, this would be done by the Referee advising the athlete directly or through his team.

6. The Referee may reconsider a decision (whether made in the first instance or in considering a protest) on the basis of any available evidence, provided the new decision is still applicable. Normally, such re-consideration may be undertaken only prior to the Victory Ceremony for the relevant event or any applicable decision by the Jury of Appeal.

This Rule clarifies that as with the Jury of Appeal (see Rule 146.9) a Referee can reconsider a decision and may do so equally whether this was a decision by himself in the first instance or one made when considering a protest made to him. This option can be considered especially when new evidence of information comes to hand quickly as it could avoid the need for a more complicated or involved appeal to the Jury of Appeal. But note the practical time limitations on such a reconsideration.

7. If, in the opinion of the appropriate Referee, circumstances arise at any competition such that justice demands that any event or any part of an event should be contested again, he shall have authority to declare the event or any part of an event void and that it shall be held again, either on the same day or on some future occasion, as he shall decide. (See also Rules 146.4 and 163.2.)

It should be carefully noted by Referees and Juries of Appeal that, except in very special circumstances, an athlete who does not finish a race, should not be advanced to a later round or included in a re-run of an event.

8. Where an athlete with a physical disability is competing in a competition under these Rules, the appropriate Referee may interpret, or allow a variation from, any relevant Rule (other than Rule 144.3) to enable the participation of the athlete provided that such variation does not provide the athlete with any advantage over another athlete competing in the same event. In the case of any doubt or if the decision is disputed, the matter shall be referred to the Jury of Appeal.

Note: This Rule is not intended to permit the participation of guide runners for visually impaired athletes, unless allowed by the regulations of a particular competition.

This Rule facilitates the participation of ambulant athletes with a disability to compete in athletic competitions with able-bodied athletes. For example, an arm amputee is not able to strictly comply with Rule 162.3 during a crouch start by putting both hands on the ground. This Rule enables a Start Referee to interpret the Rules in such a way to allow the athlete to place his stump on the ground, or to place wooden blocks or the like on the ground behind the start line on which an arm stump is placed, or in the case of a high upper arm amputee who is not able to make contact with the ground in any way, to adopt a start position without any contact with the ground.

It should be noted however that this Rule does not allow the use of guide runners in able bodied competitions (unless specifically allowed by the regulations for the particular competition) nor does it allow Referees to interpret the Rules in such a way that the relevant aspects of Rule 144 are infringed – particularly the use of technologies or appliances which would give the wearer an advantage [see Rules 144.3(c) and 144.3(d) which covers specifically the use of prostheses and other aids].

In cases where athletes with a disability are competing in the same event at the same time as able-bodied athletes and they are not compliant with the Rules (either because the Rules so specifically provide or the Referee is not able to interpret the Rules sufficiently in accordance with Rule 125.8) then a separate result should be declared for those athletes or their participation otherwise clearly indicated in the results. (See also Rule 132.3). Regardless it is always useful to indicate, in entry and start lists and in results, the IPC classification for any para-athlete who is participating.

RULE 132 COMPETITION SECRETARY, TECHNICAL INFORMATION CENTRE (TIC)

2. In events in which athletes are competing with different specifications (such as implement weights or hurdle heights), the relevant differences should be clearly indicated in the results or a separate result shown for each category.
3. Where the applicable regulations for a competition other than under Rule 1.1(a) permit the simultaneous participation of athletes
 - (a) competing with the assistance of another person, i.e. a guide runner; or
 - (b) using a mechanical aid which is not authorised under Rule 144.3(d); their results shall be listed separately and, where applicable, their para classification shown.
4. The following standard abbreviations and symbols should be used in the preparation of start lists and results where applicable:
 - Did not start – DNS
 - Did not finish – DNF (Running or Walking Events)
 - No valid trial recorded – NM
 - Disqualified – DQ (followed by the applicable Rule number)
 - Valid trial in High Jump and Pole Vault – “O”
 - Failed trial – “X”
 - Passed trial – “-”
 - Retired from competition (Field or Combined Events) – r
 - Qualified by place in track events – Q
 - Qualified by time in track events – q
 - Qualified by standard in field events – Q
 - Qualified without standard in field events – q

Advanced to next round by Referee – qR
Advanced to next round by Jury of Appeal – qJ
Bent knee (Race Walking) – “>”
Loss of contact (Race Walking) – “~”
Yellow Card – YC
Second Yellow Card – YRC
Red Card – RC

If an athlete is disqualified in an event for an infringement of any Rule, reference shall be made in the official results to the Rule which has been infringed.

If an athlete is disqualified from an event for acting in an unsporting or improper manner, reference shall be made in the official results giving reasons for such disqualification.

Rules 132.2-4 as from 2015 are designed to standardise procedures and the use of terminology in common situations in start lists and results. Rules 132.2 and 132.3 acknowledge the not uncommon situation in many competitions below the top level (and even in some high level competitions) where athletes of different age and who have para classifications are competing in the same competitions. This Rule confirms that this is acceptable - including as a means of meeting minimum competitor number requirements, even for the purposes of Rule 260.1 as well as setting out how the results should be presented. Given that disqualifications can be made for both technical and disciplinary reasons, it is very important that the reason for a disqualification is always indicated in the results. This is achieved by always stating the Rule under which the athlete was disqualified next to the symbol DQ.

5. A Technical Information Centre (TIC) will be established for competitions held under Rules 1.1(a), (b), (c), (f) and (g) and is recommended for other competitions held over more than one day. The main function of the TIC is to ensure smooth communication between each team delegation, the organisers, the Technical Delegates and the competition administration regarding technical and other matters relating to the competition.

An effectively managed Technical Information Centre will significantly assist in the delivery of a high quality competition organisation. The TIC Manager should have excellent knowledge of the Rules and equally importantly of the specific Regulations for the particular competition. The hours of operation of the TIC should reflect the hours of the competition plus some periods of time before and after when there will need to be interaction between the various parties, particularly between the team delegations and the Organisers. It is common, although not essential, for larger events to have “branches” of the TIC (sometimes called Sport Information Desks) in the main athlete accommodation locations. If this is the case, there must be excellent communication between the SID(s) and the TIC.

Because the hours of operation of the TIC and SID(s) may be long, it will be necessary for the TIC Manager to have several assistants and for them to work in shifts.

Whilst some duties of the TIC are covered in the Competition Rules (see for example Rules 132, 146.3 and 146.7), others will be set out in the Regulations for each competition and in competition documents such as team handbooks etc.

SECTION II – GENERAL COMPETITION RULES

RULE 140 THE ATHLETICS FACILITY

Any firm, uniform surface that conforms to the specifications in the IAAF Track and Field Facilities Manual, may be used for Track and Field Athletics.

Outdoor competitions under Rule 1.1(a) may be held only on facilities that hold an IAAF Class 1 Athletics Facility Certificate. It is recommended that, when such facilities are available, outdoor competitions under Rules 1.1(b) to (j) should also be held on these facilities.

In any case, an IAAF Class 2 Athletics Facility Certificate shall be required for all facilities intended for use for outdoor competitions under Rules 1.1(b) to (j).

Note (i): The IAAF Track and Field Facilities Manual, which is available from the IAAF Office, or may be downloaded from the IAAF website, contains more detailed and defined specifications for the planning and construction of Track and Field facilities including further diagrams for track measurement and marking.

Note (ii): The current standard forms required to be used for the certification application and measurement report as well as the Certification System Procedures are available from the IAAF Office, or may be downloaded from the IAAF website.

Note (iii): For Road Race Walking, Road Running or Cross-Country, Mountain and Trail courses, see Rules 230.11, 240.2, 240.3 250.1-3, 251.1 and 252.1.

Note (iv): For the indoor athletics facility, see Rule 211.

RULE 141 AGE AND SEX CATEGORIES

Age Categories

1. Competition under these Rules may be divided into age group classifications as follows:

Under-18 (U18) Boys and Girls: Any athlete of 16 or 17 years on 31st December in the year of the competition.

Under-20 (U20) Men and Women: Any athlete of 18 or 19 years on 31st December in the year of the competition.

Master Men and Women: Any athlete who has reached his/her 35th birthday.

Note (i): All other matters concerning Masters' competitions are referred to the IAAF/WMA Handbook approved by the IAAF and WMA.

Note (ii): Eligibility, including minimum ages for participation in IAAF Competitions, shall be subject to the applicable Technical Regulations.

2. An athlete shall be eligible to compete in an age group competition under these Rules if he is within the age range specified in the relevant age group classification. An athlete must be able to provide proof of his age through presentation of a valid passport or other form of evidence as permitted by the applicable regulations for the competition. An athlete who fails or refuses to provide such proof shall not be eligible to compete.

Note: See Rule 22.2 for sanctions for non-compliance with this Rule 141.

Whilst Rule 141.1 defines the age groups in a particular way, it is the regulations for each competition which determines which age groups will apply and whether, as envisaged by Note (ii), younger athletes can participate.

Sex Categories

3. Competition under these Rules is divided into men's, women's and universal classifications. When a Mixed Competition is conducted outside the stadium or in one of the limited cases set out in Rule 147, separate men's and women's classification results should still be declared or otherwise indicated. When a universal event or competition is conducted a single classification result only shall be declared.
4. An athlete shall be eligible to compete in men's (or universal) competition if he is recognised as a male in law and is eligible to compete under the Rules and Regulations.

5. An athlete shall be eligible to compete in women's (or universal) competition if she is recognised as a female in law and is eligible to compete under the Rules and Regulations.
6. The Council shall approve Regulations to determine the eligibility for women's competition of
 - (a) females who have undergone male to female sex reassignment; and
 - (b) females with hyperandrogenism.An athlete who fails or refuses to comply with the applicable regulations shall not be eligible to compete.

Note: See Rule 22.2 for sanctions for non-compliance with this Rule 141.

Universal competition covers events in which men and women participate together without separate classification of results as well as relay or team events in which both men and women are included in the same teams.

RULE 141 S 1 UKA SUPPLEMENT ADDITIONAL UKA AGE GROUPS

The Competition Year for Road Running Events shall be from 1st September each year to the following 31st August. The Competition Year for all other disciplines shall be from 1st October each year to the following 30th September.

The operative date for determining membership of age groups for all athletes under the age of 17 shall be for Track and Field and Race Walking, the 31st August at the end of the Competition Year, and for all other disciplines, the 31st August prior to the commencement of the Competition Year.

NOTE: In Northern Ireland the qualifying date for all disciplines is taken at 31st December at the end of the year of competition.

NOTE: UK Athletics Rules do not cater for athletes under the age of 11 years. This does not necessarily preclude provision by Competition

Providers for events for athletes younger than 11 years, with correspondingly reduced distances to run.

RULE 141 S 2 UKA SUPPLEMENT TRACK AND FIELD AND RACE WALKING

- (1) Under 13 Boys and Girls (School Years 6 and 7)
- (i) Track and Field competition for Under 13s shall be confined to competitors who are aged 11 or 12 on the 31st August within the Competition Year, as defined above.
 - (ii) Other than when competing in a combined event Under 13s may compete in a maximum of 4 events on one day of an athletics meeting, and if so doing, one of these must be a relay. Where a walking event is included in the total, the competitors shall be restricted to maximum of 3 running or walking event (including any relay) in one day. The total distance covered shall not exceed the maximum listed in Rule 141 S2(8). If athletes in this age group are competing in a combined event they are not allowed to compete in any other event on the same day.
 - (iii) Athletes in this age group may compete in track races not exceeding one mile subject to the restrictions in (iv) below. No Under 13 athlete is allowed to compete in any steeplechase event.
 - (iv) No athlete in this age group is allowed to compete in any race at 300 metres and 400 metres, nor in more than one race between 600 metres and one mile inclusive on the same day.
 - (v) Under 13s may run against Under 15 Boys or Girls, as appropriate, in track events not exceeding one mile, subject to any limitations as to standard laid down by the Competition Provider. They may not take part in competitions for older athletes other than those in the Under 15 age group
 - (vi) Under 13s may compete against Under 15 Boys or Girls, as appropriate, in field events, provided that the implements used by them shall be those laid down for the Under 15 age group. They may not take part in competitions for older athletes other than those in the Under 15 age group.

(vii) No athlete in this age group is allowed to compete in Triple Jump events.

(2) Under 15 Boys and Girls (School Years 8 and 9)

(i) Track and Field events for Under 15s shall be confined to competitors who are aged 13 or 14 on 31st August within the Competition Year, as defined above.

(ii) Other than when competing in a combined event Under 15s may compete in maximum of 4 events on one day of an athletics meeting, and if so doing, one of these must be a relay. Where a walking event is included in the total, the competitors shall also be restricted to a maximum of 3 running or walking events (including any relay) in one day. The total distance covered shall not exceed the maximum listed in Rule 141 S2(8). If Under 15s are competing in a combined event they are not allowed to compete in any other event on the same day.

(iii) No athlete in this age group is allowed to run in any race in excess of 3000 metres.

(iv) No athlete in this age group is allowed to run in more than one different event between 600 metres and 3000 metres inclusive on the same day.

(v) With effect from 1st April 2016 Under 15 athletes may compete in Steeplechase races over 1500m and a hurdle height of 0.762m on the understanding that this will be a development event until publication of the 2020 – 2022 Rule Book.

(vi) Under 15 athletes may compete against Under 17 Men and Women, as appropriate, in track events not exceeding 1 mile (but not steeplechase), subject to any limitations as to standard laid down by the Competition Provider. They may not take part in competitions for older athletes other than those in the Under 17 age group.

(vii) Under 15s may compete against Under 17 Men or Women, as appropriate, in field events, provided that the implements used by them shall be those laid down for the Under 17 age group. They may not take part in competitions for older athletes other than those in the Under 17 age group.

(viii) National Age Group Leagues and Home Country Championships will provide 300 metres races for the Under

15 age group. Other Competition Providers may use their discretion and include a 400 metres for Under 15 athletes within their programmes.

(3) Under 17 Men and Women (School Years 10 and 11)

- (i) Track and Field events for Under 17s shall be confined to competitors who are aged 15 or 16 on 31st August within the Competition Year, as defined above.
- (ii) Other than when competing in a combined event, Under 17s may compete in maximum of four events on one day of an athletics meeting, and if so doing, one of these must be a relay. If Under 17s are competing in a combined event they are not allowed to compete in any other event on the same day.
- (iii) No athlete in this age group is allowed to run in any track event in excess of 5000 metres.
- (iv) Under 17 athletes may compete against Under 20s or Seniors in track events, including National and County Championships, in events not exceeding 3000 metres (including steeplechase), subject to any limitations as to standard laid down by the Competition Provider.
- (v) Under 17s may compete against Under 20s or Seniors in field events, provided the implements to be used are those laid down for the older age group.

(4) Under 20 Years Men and Women

- (i) Track and Field events for Under 20s shall be confined to competitors who are 17 or over on 31st August within the Competition Year, as defined above, but Under 20 on 31st December in the calendar year of competition.
- (ii) Under 20s may not compete in more than five events on the same day of an athletics meeting. If Under 20s are competing in a combined event they are not allowed to compete in any other event on the same day.
- (iii) Under 20s may only run in track events up to and including 10000 metres.
- (iv) Under 20s may run against Seniors in open track events, including National and County Championships, up to and including 10,000 metres.
- (v) Under 20s may compete against Seniors in open field event competitions, including National and County Championships,

provided that the implements used by them shall be those laid down for Senior competition.

(5) Seniors

A Senior is a competitor who is at least 20 years of age on 31st December in the calendar year of competition.

(6) Masters

Events for Masters shall be confined to athletes who are at least 35 years of age on the day of competition.

(7) Graded Events

The organisers of a graded competition may allow competitors in younger age groups to compete against older athletes provided that the conditions do not contravene any rules regarding distances or events which may be contested. Mixed graded competitions are defined in Rule 147 S1.

(8) Race Walking

The maximum permitted distances for Race Walking events (track and road) shall be:

Age Group	Maximum Distance All Athletes
Under 13 years	3,000 metres
Under 15 years	5,000 metres
Under 17 years	15,000 metres
Under 20 years	20,000 metres
Seniors	Unlimited

Ages for maximum distances are as at 31st August in the year of competition.

**RULE 141 S 3 UKA SUPPLEMENT
CROSS COUNTRY AND ROAD AGE GROUPS**

- (1) Road Race Competition Providers may make such age limits as they think fit provided that the conditions of the race do not contravene any rules regarding distances which may be run, and provided that the race is not advertised under the title of any of the recognised age categories as listed below.

- (i) **Under 13 Boys and Girls (School Years 7 & 8 and some year 6)**
Cross Country and Road Running competitions for Under 13s shall be confined to competitors who are aged 11 on the day of competition, or 12 on 31st August prior to the commencement of the Competition Year as defined above.
- (ii) **Under 15 Boys & Girls (School Years 9 & 10)**
Cross Country and Road Running competitions for Under 15s shall be confined to competitors who are aged 13 or 14 on 31st August prior to the commencement of the Competition Year as defined above.
- (iii) **Under 17 Men & Women (School Years 11 & 12)**
Cross Country and Road Running competitions for Under 17s shall be confined to competitors who are aged 15 or 16 on 31st August prior to the commencement of the Competition Year as defined above.
- (iv) **Under 20 Men & Women**
Cross Country and Road Running competitions for Under 20 Men and Women shall be confined to competitors who are aged 17, 18 or 19 on 31st August prior to the commencement of the Competition Year as defined above.
- (v) **Senior Men & Women**
For Cross Country and Road Running competitions a Senior is a competitor who is aged at least 20 years on 31st August prior to the commencement of the Competition Year as defined above. In Road Relay Competitions Under 20 Men and Women, as appropriate, may compete in Senior events.
- (vi) **Masters Men and Women**
Cross Country and Road Running events for Masters shall be confined to competitors who are at least 35 years of age on the date of the competition.

(2) Cross Country Maximum Distances

Age Group	Maximum Distance All Athletes
Under 13 years	3,500 metres
Under 15 years	5,000 metres
Under 17 years	6,500 metres
Under 20 years	10,000 metres
Seniors	Unlimited

(3) Road Maximum Distances

Age on day of competition	Maximum Distance All Athletes
Over 11 – Under 13	5,000 metres
Over 13 – Under 15	6,000 metres
Aged 15 years	10,000 metres
Aged 16 years	15,000 metres
Aged 17 years	25,000 metres
Over 18 – Under 20	Marathon
Seniors	Unlimited
Masters	Unlimited

RULE 141 S 4 UKA SUPPLEMENT FELL, HILL AND MOUNTAIN RUNNING

Competition Providers must stipulate age limits for their events but the following limits for younger runners must be observed:

The maximum distances for younger runners shall be:

Age on 1st January in year of competition	Maximum Distance All Athletes
Under 12 years	3,000 metres
Under 14 years	5,000 metres
Under 16 years	7,000 metres
Under 18 years	10,000 metres

For paired Mountain Marathon style orienteering events, over one or two days, where one of the two runners is under 18, the other runner must be over 20 and must also be the parent or guardian of the junior runner. The minimum age for the junior runner is 14 and the following straight line distance limits must apply for each day of the event.

Under 16 years	20,000 metres
Under 18 years	25,000 metres

RULE 141 S 5 UKA – TRAIL RUNNING

Subject to satisfying HUE ‘Adventure Activity Licensing Regulations’ for youths under eighteen, the maximum distances permitted for the following age groups are:

Under 12 years	3,000 metres
Under 14 years	5,000 metres
Under 16 years	6,000 metres
Under 17 years	10,000 metres
Under 18 years	25,000 metres
Under 20 years	45,000 metres

Veteran Men and Women: For Trail Running a veteran is a competitor aged at least 40 years on the day of the competition.

RULE 142 ENTRIES

1. Competitions under the Rules are restricted to eligible athletes.
2. The eligibility of an athlete to compete outside of his own country is as set forth in Rule 4.2. Such eligibility shall be assumed unless an objection to his status is made to the Technical Delegate(s). (See also Rule 146.1.)

Simultaneous Entries

3. If an athlete is entered in both a Track Event and a Field Event, or in more than one Field Event taking place simultaneously, the appropriate Referee may, for one round of trials at a time, or for each trial in the High Jump and Pole Vault, allow an athlete to take his trial in an order different from that decided upon by the draw prior to the start of the competition. However, if an athlete subsequently is not present for a particular trial, it shall be deemed that he is passing once the period allowed for the trial has elapsed.

Note: In Field Events, the Referee shall not allow an athlete to take a trial in a different order in the final round of trials but the Referee may allow an athlete to do so during any earlier round of trials. In Combined Events, a change may be allowed in any round of trials.

The Note clarifies that allowing an athlete to take a trial in a different order in the final round of trials (irrespective of the number of rounds of trials) because of a clash with another event is not permitted. If an athlete is not present in the final round and has not previously indicated that he will pass, then the time allowed for his trial will run and if he does not return before it expires, then he will be recorded as passing. [See also Rule 180.18 where a change of order will normally not be made when a substitute trial is awarded - in any round of trials.]

Failure to Participate

4. At all competitions under Rules 1.1(a), (b), (c) and (f), an athlete shall be excluded from participation in all further events (including other events in which he is simultaneously participating) in the competition, including relays, in cases where:
- (a) a final confirmation was given that the athlete would start in an event but then failed to participate;

Note: A fixed time for the final confirmation of participation shall be published in advance.

- (b) an athlete qualified in any Qualification Round of an event for further participation in that event but then failed to participate further;

Note: For the avoidance of doubt, Rules 142(4)(b) and (c) shall apply to all competitions held under UKA rules.

- (c) an athlete failed to compete honestly with bona fide effort. The relevant Referee will decide on this and the corresponding reference must be made in the official results.

Note: The situation foreseen in Rule 142.4(c) will not apply to individual events within Combined Events.

However, a medical certificate, provided by and based on an examination of the athlete by the Medical Delegate appointed under Rule 113 or, if no Medical Delegate has been so appointed, by a medical doctor so designated by the Organisers, may be accepted as sufficient reason to accept that the athlete became unable to compete after confirmations closed or after competing in a previous round but will be able to compete in further events (except Combined Events individual events) on a subsequent day of the competition. Other justifiable reasons (e.g. factors independent of the athlete's own actions, such as problems with the official transport system) may, after confirmation, also be accepted by the Technical Delegate(s).

The relevant Referee, once aware of such a situation and is satisfied that the athlete who abandoned the race was not competing with a bona fide effort, must make a reference to this in the relevant results as “DNF Rule 142.4.(c)”. Either in the process of the Referee making such a decision or the Jury of the Appeal considering any protest arising from it, reasons for the withdrawal or non-participation proposed by or on behalf of the athlete can be considered. The Rule sets out the process that should explicitly be followed in the case of a medical reason.

Failure to Report to the Call Room(s)

Subject always to any additional sanction under Rule 142.4, and except as provided below, an athlete shall be excluded from participation in any event in which he is not present in the Call Room(s) at the relevant time as published in the Call Room schedule (see Rule 136). He shall be shown in the results as DNS.

The relevant Referee will decide on this (including whether the athlete may compete under protest if a decision cannot be made immediately) and the corresponding reference must be made in the official results.

Justifiable reasons (e.g. factors independent of the athlete's own actions, such as problems with the official transport system or an error in the published Call Room schedule) may, after confirmation, be accepted by the Referee and the athlete may then be allowed to take part.

RULE 142 S 1 UKA SUPPLEMENT ENTRIES

- (1) Every entry, either by hard copy or electronically as required by the Competition Provider, shall be made to the authorised official of the Competition Provider. Every entry must be dated and state fully and accurately the particulars required by the official entry form, including the true, legally registered name, address, date of birth, National Association Registration Number and affiliated Club of the competitor. No one shall be allowed to compete unless an entry form is completed in accordance with this Rule and anyone whose entry form is not so completed shall forfeit the entrance fee.
- (2) Any Competition Provider has the right to refuse any entry without assigning a reason to the entrant, but the reason must be disclosed to the Licensing Authority if requested.
- (3) No entry either for individual or team events may be made except upon the form of entry issued or approved by the Licensing Authority.
- (4) Every individual entry shall be confirmed by the intending competitor, who shall be responsible for all statements therein and any omissions there from, whether the athlete actually made the entry or not. Any individual making a false entry shall be dealt with for misconduct. (as defined in Rule 145 S1).
- (5) Every entry for an event limited by age shall state the date of birth of the intending competitor and every such entry shall, if required, be verified subsequently by the production of a birth certificate.
- (6) Where a team declaration is required for an event, this entry shall be verified by an authorised official of the Club on whose behalf the entry is made, and the Club shall be responsible for the accuracy of the information given by such official. Any affiliated Club making a false entry shall be dealt with for misconduct. (as defined in Rule 145 S1).
- (7) Participation in a competition under UKA Rules shall only be valid if the stipulated entry fee has been received.
- (8) All advertisements, and programmes (whether printed or electronic) shall state that the meeting or competition is being held “Under UKA Rules”.
- (9) Competition Providers of an Open Team event must declare in advance which team awards are included within the event or race and the manner in which they will be decided. In the case of a relay

race the distance of each section and the order in which sections are to be run must be similarly declared.

RULE 142 S 2 UKA SUPPLEMENT ROAD RACES

- (1) Any Competition Provider applying for a Road Race Licence must set a final closing date for the normal acceptance of entries and may determine a limit to the maximum number of entries that will be accepted. Any competitor entering after this date may, if the entry is accepted, be charged an additional late entry fee if the Competition Provider so wishes.
- (2) A Competition Provider must exhibit a listing, or provide a programme, showing all entries received by the published closing date. A list of all entrants, including any late entrants, must be provided to the Referee on request before the start of the race.
- (3) A runner whose entry is accepted after the published closing date may, at the discretion of the Competition Provider:
 - (i) not be eligible for any individual prize.
 - (ii) not be eligible as a scoring team member in a team race.
- (4) Runners who compete in any road race which does not have a UKA licence may thereby render themselves liable to suspension. This does not apply in the case of fun runs.

RULE 142 S 3 UKA SUPPLEMENT FELL, HILL AND MOUNTAIN RUNNING

No runner may take part in any race without having entered the race in accordance with the current appropriate Safety requirements.

RULE 142 S 4 UKA SUPPLEMENT TRAIL RACES

The Competition Provider may accept entries after the published closing date, but decide such competitors are not eligible for individual prizes and/or are not eligible to be scoring team members. These limitations should be made clear at the time of accepting the entry.

RULE 143 CLOTHING, SHOES AND ATHLETE BIBS

Clothing

1. In all events, athletes must wear clothing which is clean, and designed and worn so as not to be objectionable. The clothing must be made of a material which is non-transparent even if wet. Athletes must not wear clothing which could impede the view of the Judges. Athletes' vests should have the same colour on the front and back. At all competitions under Rules 1.1(a), (b), (c), (f) and (g), and when representing their National Federation under Rules 1.1(d) and (h), athletes shall participate in the uniform clothing approved by their National Federation and, at all competitions under Rules 1.1(a), (b), (c), (f) and (g), Neutral Athletes shall participate in the uniform clothing approved by the IAAF. The Victory Ceremony and any lap of honour are considered part of the competition for this purpose.

Note: The relevant governing body may specify in the regulations for a competition that it is mandatory for the colour on athletes' vests to be the same on the front and back.

Shoes

2. Athletes may compete barefoot or with footwear on one or both feet. The purpose of shoes for competition is to give protection and stability to the feet and a firm grip on the ground. Such shoes, however, must not be constructed so as to give athletes any unfair assistance or advantage. Any type of shoe used must be reasonably available to all in the spirit of the universality of athletics.

Note (i): Adapting a shoe to suit the characteristic of a particular athlete's foot is permitted if made in accordance with the general principles of these Rules.

Note (ii): Where evidence is provided to the IAAF that a type of shoe being used in competition does not comply with the Rules or the spirit of them, it may refer the shoe for study and if there is non-compliance may prohibit such shoes from being used in competition.

Number of Spikes

3. The sole and heel of the shoes shall be so constructed as to provide for the use of up to 11 spikes. Any number of spikes up to 11 may be used but the number of spike positions shall not exceed 11.

Dimensions of Spikes

4. That part of each spike which projects from the sole or the heel shall not exceed 9mm except in the High Jump and Javelin Throw, where it shall not exceed 12mm. The spike must be so constructed that it will, at least for the half of its length closest to the tip, fit through a square sided 4mm gauge. If the track manufacturer or the stadium operator mandates a lesser maximum, this shall be applied.

Note: The surface must be suitable for accepting the spikes permitted under this Rule.

The Sole and the Heel

5. The sole and/or heel may have grooves, ridges, indentations or protuberances, provided these features are constructed of the same or similar material to the basic sole itself.

In the High Jump and Long Jump, the sole shall have a maximum thickness of 13mm and the heel in High Jump shall have a maximum thickness of 19mm. In all other events the sole and/or heel may be of any thickness.

Note: The thickness of the sole and heel shall be measured as the distance between the inside top side and the outside under side, including the above-mentioned features and including any kind or form of loose inner sole.

Inserts and Additions to the Shoe

6. Athletes may not use any appliance, either inside or outside the shoe, which will have the effect of increasing the thickness of the sole above the permitted maximum, or which can give the wearer any advantage which he would not obtain from the type of shoe described in the previous paragraphs.

Athlete Bibs

7. Every athlete shall be provided with two bibs which, during the competition, shall be worn visibly on the breast and back, except in the Jumping Events, where one bib may be worn on the breast or

||

back only. Either the athletes' names or other suitable identification will be allowed instead of numbers on any or all of the bibs. If numbers are used, they shall correspond with the number allocated to the athlete on the start list or in the programme. If track suits are worn during the competition, bibs shall be worn on the track suit in a similar manner.

8. No athlete shall be allowed to take part in any competition without displaying the appropriate bib(s) and/or identification.
9. These bibs must be worn as issued and may not be cut, folded or obscured in any way. In long distance events, the bibs may be perforated to assist the circulation of air, but the perforation must not be made on any of the lettering or numerals which appear on them.
10. Where a Photo Finish System is in operation, the Organisers may require athletes to wear additional number identification of an adhesive type on the side of their shorts or lower body.
11. If an athlete does not follow this Rule in any way and:
 - (a) refuses the direction of the relevant Referee to comply; or
 - (b) participates in the competition,
he shall be disqualified.

Rule 143.11 prescribes the sanction if any aspect of Rule 143 is not followed. It is expected however that where possible the relevant officials should request and encourage the athlete to comply and to advise him of the consequence if he does not. But where an athlete does not follow an aspect of the Rule during competition and it is not practical for an official to request compliance that disqualification may, or will, follow.

It is a responsibility of the Starters Assistants and Umpires (for Track and Out of Stadium Events) and the Judges (for Field Events) to be vigilant on these matters and report any apparent breaches to the relevant Referee.

RULE 143 S 1 UKA SUPPLEMENT CLOTHING

- (1) All advertising and sponsorship contracts (other than the sponsorship of events) with any Club or individual athlete under the jurisdiction of UKA must be registered with UKA.

- (2) For all competitions held under IAAF rules clothing (deemed to include track suits and any other equipment) must comply with these rules and associated IAAF Regulations.
- (i) Should athletes or clubs wish to wear an identification of a personal sponsor in UKA events then the identification may appear only once and must be a maximum of 20 square cm, with any lettering maximum height of 4cm. If the identification is solely a logo then this must be a maximum of 20 square cm with a maximum height of 5cm. This is subject to IAAF clauses 8 (2) & 143 (1) above and the requirement that the specific design of the advertising material to be used, together with the name of the sponsor(s) shall be submitted by the Club to their National Association for prior approval and registration. For the avoidance of doubt this need for approval by National Associations does not apply to “branded” clothing and equipment available on the open market provided by bona fide suppliers of athletic clothing and equipment.
 - (ii) Should athletes or clubs wish to wear an identification of a personal sponsor in UKA domestic events whose size is in excess of clause (1) above, the specific design of the advertising material to be used, together with the name of the sponsor(s) shall be submitted by the Club to their National Association for prior approval, acting reasonably, and registering. This is subject to IAAF clauses 8 (2) & 143 (1) above.

NOTE 1: Where this approval is obtained the athlete is warned that in any competitions held under IAAF rules or where the licence conditions require IAAF regulation compliance then the athlete must have an alternative kit to wear in those competitions and approval under this clause does not over-ride the IAAF requirements.

NOTE 2: IAAF Advertising Regulation 4.1.2.1 allows a manufacturer’s logo to be 30 square cm with a maximum height 5cm and a maximum letter height of 4cm.

- (3) In team or relay races all competitors must wear registered vests of the same design and colour of the team they are representing unless the Referee has given permission for a change to be made.

NOTE 1: This Rule does not preclude the possibility of clothing being different in style between participants in the same team e.g. vests of different length, cut of sleeve or collar etc. Any team clothing should, though, still broadly correspond in colour and design notwithstanding these differences.

NOTE 2: Clubs are permitted to have two sets of colours registered at any one time.

- (4) In individual English County, English Area, Scottish District, Welsh Regional and National Championships, (but excluding Road Running) athletes must wear the vest of their first-claim affiliated Club, their County, Area, District, Regional or National vest, or any other Representative vest approved by UKA. The affiliated Club concerned must be the one which in terms of Rule 21 S2(4) caters for that particular discipline of athletics.

NOTE: In exceptional circumstances the Referee may grant permission for an alternative vest to be worn.

- (5) Except as is allowed for in this rule, competitors are not allowed to take into an arena or course any form of advertising material, nor to display on their person any such advertising other than:
- (i) the accepted name of their affiliated Club in lettering which should not exceed 4cm in height. In the case of County vests the lettering indicating the name shall not exceed 6cm in height.
 - (ii) a single Trade Mark of the manufacturer of the clothing they are wearing which may appear on the upper body attire. This Mark must not exceed 20 square cm, with the lettering maximum height of 4cm and the total logo maximum height of 5cm. On lower body attire the logo shall not exceed 20 square cm with maximum height of 4cm and may only appear once.

(6) Track & Field

Footwear

NOTE: For non-synthetic surfaces the maximum length of spike shall be 25mm and the maximum diameter 4mm.

(7) Race Walking

In order that judges may apply the Rules relating to walking, competitors' knees shall normally be bare. If garments are worn that cover the knee, the Referee's permission must be obtained before the commencement of the race, and the Chief Judge notified. Any competitor starting without permission will be disqualified by the Referee.

RULE 143 S 2 UKA SUPPLEMENT ATHLETE BIBS

- (1) Every athlete shall be provided with at least one bib which shall normally be worn on the breast and show a suitable identification number or name.
- (2) **Road Races**
 - (i) There should be provision for medical information and contact details on the reverse of the bib for prior completion by the athlete.
 - (ii) In Road Relays every athlete must wear the supplied bib(s), which must serve to identify the team and should also identify the stage that the athlete is running.
 - (iii) Numbers are issued to the individual athlete completing the application form except with the specific authority of the Competition Provider. Athletes who receive transferred numbers without permission will be disqualified from the race. Both runners will be subject to disciplinary action by the appropriate National Association.
 - (iv) A runner must retire immediately if ordered to do so by a medical officer of the race.
 - (v) Runners who retire from a race must not remove their bib until they have reported to an official as having retired from the race.

RULE 144 ASSISTANCE TO ATHLETES

Medical Examination and Assistance

1. Medical examination / treatment and/or physiotherapy may be provided either on the competition area itself by the official medical

staff appointed by the Organisers and identified by armbands, vests or similar distinctive apparel or in designated medical treatment areas outside the competition area by accredited team medical personnel specifically approved by the Medical or Technical Delegate(s) for the purpose. In neither case shall the intervention delay the conduct of the competition or an athlete's trial in the designated order. Such attendance or assistance by any other person, whether immediately before competition, once athletes have left the Call Room or during competition, is assistance.

Note: The competition area, which normally also has a physical barrier, is defined for this purpose as the area where the competition is being staged and which has an access restricted to the competing athletes and personnel authorised in accordance with the relevant Rules and Regulations.

2. Any athlete giving or receiving assistance from within the competition area during an event (including under Rule 163.14, 163.15, 230.10 and 240.8) shall be warned by the Referee and advised that, if there is any repetition, he will be disqualified from that event.

Note: In cases under Rule 144.3(a), disqualification may be made without warning.

Assistance not Allowed

3. For the purpose of this Rule, the following examples shall be considered assistance, and are therefore not allowed:
 - (a) Pacing in races by persons not participating in the same race, by athletes lapped or about to be lapped or by any kind of technical device (other than those permitted under Rule 144.4(d)).
 - (b) Possession or use of video recorders, radios, CD, radio transmitters, mobile phone or similar devices in the competition area.
 - (c) Except for shoes complying with Rule 143, the use of any technology or appliance that provides the user with an advantage which he would not have obtained using the equipment specified in, or permitted by, the Rules.
 - (d) The use of any mechanical aid, unless the athlete can establish

on the balance of probabilities that the use of an aid would not provide him with an overall competitive advantage over an athlete not using such aid.

- (e) Provision of advice or other support by any official of the competition not related to or required by his specific role in the competition at the time (e.g., coaching advice, indication of the take-off point in a jumping event except to indicate a failure in Horizontal Jumps, time or distance gaps in a race etc.).
- (f) Receiving physical support from another athlete (other than helping to recover to a standing position) that assists in making forward progression in a race.

Assistance Allowed

4. For the purposes of this Rule, the following shall not be considered assistance, and are therefore allowed:

- (a) Communication between the athletes and their coaches not placed in the competition area.

In order to facilitate this communication and not to disturb the staging of the competition, a place in the stands, close to the competition area of each Field Event, should be reserved to the athletes' coaches.

Note: Coaches and other persons otherwise complying with Rules 230.10 and 240.8 may communicate with their athlete(s).

- (b) Medical examination / treatment and/or physiotherapy necessary to enable an athlete to participate or continue participation once on the competition area under Rule 144.1.
- (c) Any kind of personal safeguard (e.g. bandage, tape, belt, support, wrist cooler, breathing aid etc.) for protection and/or medical purposes. The Referee, in conjunction with the Medical Delegate, shall have the authority to verify any case should he judge that to be desirable. (See also Rules 187.4 and 187.5.)
- (d) Heart rate or speed distance monitors or stride sensors or similar devices carried or worn personally by athletes during an event, provided that such device cannot be used to communicate with any other person.

- (e) Viewing by athletes competing in Field Events, of images of previous trial(s), recorded on their behalf by persons not placed in the competition area (see 144.1 Note). The viewing device or images taken from it must not be taken into the competition area.
- (f) Hats, gloves, shoes, items of clothing provided to athletes at official stations or when otherwise approved by the relevant Referee.

Rule 144 has been the subject of constant change in recent years to reflect the way in which athletics is conducted, to respect the role of coaches, to manage innovation and new products, etc. The IAAF will continue to respond to new products and trends as soon as they become common place during events and competitions.

Changes to these Rules are designed to facilitate the athletes' participation in the competition as much as possible and to reduce unnecessary conflict between athletes/coaches and the officials. Each of these Rules should be interpreted in this light whilst always ensuring the competition is conducted fairly to all.

Rule 144.3(e) however makes it clear that the officials should not assist any athlete beyond what is required of their role – and specifically states as an example that officials should not provide details of the take-off position in jumping events, other than for the purpose of indicating the point of “impact” in a foul jump in Horizontal Jumps.

RULE 145 EFFECT OF DISQUALIFICATION

Disqualification resulting from an infringement of a Technical Rule (other than Rules 125.5 and 162.5)

1. If an athlete is disqualified in an event for an infringement of a Technical Rule (except under Rules 125.5 or 162.5) any performance accomplished in the same round of that event up to the time of the disqualification shall not be valid. However, performances accomplished in a previous round of that event shall remain valid. Such disqualification from an event shall not prevent an athlete from taking part in any further event in that competition.

Disqualification resulting from exclusion under Rule 125.5 (including under Rule 162.5)

2. If an athlete is excluded from competition under Rule 125.5, he shall be disqualified from that event. If the athlete's second warning occurs in a different event, he shall be disqualified only from the second event. Any performance accomplished in the same round of that event up to the time of the disqualification shall not be valid. However, performances accomplished in a previous round of that event, other previous events or previous individual events of a Combined Event shall remain valid. Such disqualification shall prevent an athlete from taking part in all further events, (including individual events of a Combined Event, other events in which he is simultaneously participating and relays) in that competition.
3. If the offence is considered serious, the Competition Director shall report it to the relevant governing body for consideration of further disciplinary action.

RULE 145 S 1 UKA SUPPLEMENT MISCONDUCT

- (1) Any individual athlete or official of an affiliated Club making a false entry for competition shall be dealt with by the appropriate National Association for misconduct.
- (2) Any competitor (or other person) interfering or attempting to interfere with the decision of an event official, or indulging in unfair practices or misbehaviour, including the use of offensive or abusive language shall, at the discretion of the Referee, be disqualified from the competition and, if deemed necessary, reported to the appropriate National Association for further action. Performances achieved in the competition from which they were disqualified shall not stand.

NOTE: The use of offensive language audible to others should normally attract a warning from the Referee, but, if targeted at an official, should immediately attract a disqualification.

- (3) Athletes or officials who breach the Rules of Competition or conduct themselves in a manner which may bring discredit to the sport of athletics may be reported to the appropriate National Association to take such action as it deems necessary.

RULE 146 PROTESTS AND APPEALS

1. Protests concerning the status of an athlete to participate in a competition must be made, prior to the commencement of such competition, to the Technical Delegate(s). Once the Technical Delegate(s) make(s) a decision, there shall be a right of appeal to the Jury of Appeal. If the matter cannot be settled satisfactorily prior to the competition, the athlete shall be allowed to compete "under protest" and the matter be referred to the relevant governing body.
2. Protests concerning the result or conduct of an event shall be made within 30 minutes of the official announcement of the result of that event. The Organisers of the competition shall be responsible for ensuring that the time of the announcement of all results is recorded.
3. Any protest shall be made orally to the Referee by an athlete, by someone acting on his behalf or by an official representative of a team. Such person or team may protest only if they are competing in the same round of the event to which the protest (or subsequent appeal) relates (or are competing in a competition in which a team points score is being conducted). To arrive at a fair decision, the Referee should consider any available evidence which he thinks necessary, including a film or picture produced by an official video recorder, or any other available video evidence. The Referee may decide on the protest or may refer the matter to the Jury of Appeal. If the Referee makes a decision, there shall be a right of appeal to the Jury. Where the Referee is not accessible or available, the protest should be made to him through the Technical Information Centre.
4. In a Track Event,
 - (a) if an athlete makes an immediate oral protest against having been charged with a false start, a Track Referee may, if he is in any doubt, allow the athlete to compete "under protest" in order to preserve the rights of all concerned. Competing "under protest" shall not be allowed if the false start was indicated by an IAAF certified Start Information System, unless for any reason the Referee determines that the information provided by the System is obviously inaccurate.
 - (b) a protest may be based on the failure of the Starter to recall a false start or, under Rule 162.5, to abort a start. The protest may be made only by, or on behalf of, an athlete who has completed

the race. If the protest is upheld, any athlete who committed the false start or whose conduct should have led to the start being aborted, and who was subject to warning or disqualification according to Rules 162.5, 162.7, 162.8 or 200.8(c), shall be warned or disqualified. Whether or not there may be any warning or disqualification, the Referee shall have the authority to declare the event or part of the event void and that it or part of it shall be held again if in his opinion justice demands it.

Note: The right of protest and appeal in Rule 146.4(b) shall apply whether or not a Start Information System is used.

- (c) if a protest or appeal is based on an athlete's incorrect exclusion from an event due to a false start and it is upheld after the completion of the race, then the athlete should be afforded the opportunity to run on his own to record a time in the event and consequently, if applicable, to be advanced to subsequent rounds. No athlete should be advanced to a subsequent round without competing in all rounds unless the Referee or Jury of Appeal determines otherwise in the particular circumstances of the case, e.g. the shortness of time before the next round or the length of the race.

Note: This Rule may also be applied by the Referee, the Jury of Appeal in other circumstances where it is deemed appropriate (see Rule 163.2).

When the Start Referee decides on an immediate oral protest made by an athlete for being charged with a false start, he has to consider all the available data and in case of only a reasonable possibility that the athlete's protest may be valid, he should allow the athlete to compete under protest. After the race, a final decision must be taken by the Referee, a decision that may be subject of an appeal to the Jury. But to be clear, the Referee should not allow an athlete to compete under protest if the false start has been detected by a Start Information System that appears to be working properly or in cases where it is very clear by visual observation that the athlete has committed a false start and there is no valid reason to allow the protest.

These Rules not only apply where a Starter failed to recall a false start but where also a Starter failed to correctly "abort" a start. In both cases the Referee must consider all factors involved in the particular case and

must decide if the race (or part of it) has to be re-held.

Giving two examples of extreme situations, it will not be logical or necessary to re-run a Marathon race in a case where an athlete who finishes was responsible for a non-recalled false start. But the same will probably not be the case in a sprint event where an athlete was responsible for a non-recalled false start as this may have affected the start and subsequent race of other athletes.

On the other hand, if for example in a preliminary round, or perhaps even more so in a race within a Combined Event, it was clear that only one or some athletes were disadvantaged by a failure to recall a false start or to abort a start, a Referee could decide that only those athletes be given the opportunity to run again – and if so under what conditions.

Rule 146.4 (c) covers the situation in which an athlete is wrongly given a false start and excluded from a race.

5. In a Field Event, if an athlete makes an immediate oral protest against having a trial judged as a failure, the Referee of the event may, if he is in any doubt, order that the trial be measured and the result recorded, in order to preserve the rights of all concerned.

If the protested trial occurred:

- (a) during the first three rounds of trials of a horizontal Field Event in which more than eight athletes are competing, and the athlete would advance to any subsequent rounds of trials only if the protest or subsequent appeal was upheld; or
- (b) in a vertical Field Event, where the athlete would advance to a higher height only if the protest or subsequent appeal is upheld, the Referee may, if he is in any doubt, allow the athlete to continue competing “under protest” to preserve the rights of all concerned.

In cases where the Referee is sure that the decision of the Judges is correct, particularly by his own observation or advice received from a Video Referee, the athlete should not be allowed to continue.

But when considering whether to order the measurement of a trial which is the subject of an immediate oral protest the Referee should:

- (a) not do so in cases where there was a clear breach of the Rules, for example in the long jump a clear mark made in the plasticine by the athlete in question or in a throwing event where the implement has clearly

landed outside the sector;

(b) always do so (and immediately so as to not delay the competition) in cases where there is any doubt.

The good operation of this Rule means that the Judge with the spike or prism should always mark the point of landing (except in throwing events where the implement clearly lands outside the sector) even when they see a red flag. Apart from the possibility that the athlete may make an immediate oral protest, it is also possible that the Judge with the flags may have incorrectly or accidentally raised the wrong one.

6. The protested performance of the athlete and any other performance achieved by him while competing “under protest” will become valid only if a subsequent decision to that effect is made by the Referee or an appeal to the Jury of Appeal is made and it is upheld.

Rule 146.6 applies to all events, not only to Field Events. However, in Field Events where, as a result of an athlete competing “under protest”, another athlete is allowed to continue in the competition when he would otherwise not have done so, such athlete’s performances and eventual results will remain valid irrespective of whether the “under protest” athlete’s immediate oral protest is successful.

7. An appeal to the Jury of Appeal must be made within 30 minutes:
 - (a) of the official announcement of the amended result of an event arising from the decision made by the Referee; or
 - (b) of the advice being given to those making the protest, where there is no amendment of any result.

It shall be in writing, signed by the athlete, by someone acting on his behalf or by an official representative of a team and shall be accompanied by a deposit of USD 100, or its equivalent, which will be forfeited if the appeal is not allowed. Such athlete or team may appeal only if they are competing in the same round of the event to which the appeal relates (or are competing in a competition on which a team points score is being conducted).

Note: The relevant Referee shall, after his decision on a protest, immediately inform the TIC of the time of the decision. If the Referee was unable to communicate his decision orally to the

relevant team(s) /athlete (s), the official time of the announcement will be that of posting of the amended result or of the decision at the TIC.

8. The Jury of Appeal shall consult all relevant persons, including the relevant Referee (except when his decision is to be fully maintained by the Jury of Appeal). If the Jury of Appeal is in doubt, other available evidence may be considered. If such evidence, including any available video evidence, is not conclusive, the decision of the Referee or the Chief Race Walking Judge shall be upheld.
9. The Jury of Appeal may reconsider a decision if new conclusive evidence is presented, provided the new decision is still applicable. Normally, such re-consideration may be undertaken only prior to the Victory Ceremony for the applicable event, unless the relevant governing body determines that circumstances justify otherwise.

In certain circumstances the Judges (Rule 126.2), the Referee (Rule 125.6) and the Jury (Rule 146.9) can each reconsider a decision made by them – if it is still applicable and practical to do so.

10. Decisions involving points which are not covered by the Rules shall be reported subsequently by the Chairman of the Jury of Appeal to the Chief Executive Officer of the IAAF.
11. The decision of the Jury of Appeal (or of the Referee in the absence of a Jury of Appeal or if no appeal to the Jury is made) shall be final and there shall be no further right of appeal, including to CAS.

RULE 146 S 1 UKA SUPPLEMENT PROTESTS AND APPEALS

For meetings where there is no Jury of Appeal and / or Technical Information Centre the following provisions shall apply:

(1) Qualification to compete

(i) Protest

- (a) Any protest or objection against the qualification to compete, or the statements in the entry form of another competitor or Club, shall be made to the appropriate Referee as early as possible and where practicable such

protest or objection should be made before the commencement of the competition. Where the protest relates to competitors' eligibility to compete, by means of registration or equivalent, the referee may refer the matter to the Competition Provider or National Association to determine. They may decide the protest or objection at the event or after investigation, such investigations should be concluded within one week of the competition date. In the event of a protest or objection being lodged against a successful competitor or team, the prize or prizes shall be withheld until the protest or objection has been disposed of in a manner provided for in this Rule.

- (b) To assist in the compliance of athlete registration and thereby eligibility to compete the National Associations should undertake checks on competition results to ensure that athletes are registered in compliance with "IAAF rule 21 UKA Supplement 1(1) Eligible athletes". Such checks will be undertaken within one week of the competition. Following the conclusion of their investigations, if the National Association decides that the athlete is ineligible they must forthwith notify the Competition Provider which should then adjust the results of its competition in accordance with its rules.
- (c) In the event of a successful protest under (1)(i)(a) and (b) above the Competition Provider should re-score the competition in accordance with the rules of the competition.

(ii) Appeal

- (a) In the event that the protestor has not accepted the decision reached after investigation they or an authorised official shall take action by objecting directly to the National Association in writing within one week of the decision.
- (b) In the event of an Appeal against a decision by a National Association solely with regard to registration, the National Association will set up an Independent Panel to determine the Appeal. Such determination should be

made within one week of receipt of the Appeal.

(2) Technical Rules, Conduct or Placing

- (i) Any protest or objection by a competitor or team against the conduct or placing of another competitor or team in any competition, or relating to any matter which may develop during the event, shall be made to the appropriate Referee immediately after that event or competition, or immediately after the results are published.
- (ii) Every protest or objection lodged under (2)(i) may be made verbally by the individual competitor or by a member of the protesting Club.
- (iii) The Referee shall decide any protest or objection made under (2)(i) having reviewed all the relevant information, on the ground, or after investigation. The Referee's decision shall be final.
- (iv) Where protests are made in respect of the Start, the Starter's decision is final.
- (v) Cross Country and Road Races: If the results are not available at the conclusion of the event, then such a protest may be made at any time up until one week after the publication of the results. In such cases the protest should be made to the Referee through the Competition Provider. If, as a result of a protest under (2)(i) or (2)(ii) above, a runner is disqualified or the race result otherwise altered, the Referee shall inform the Competition Provider of that amended result, in writing, within one week. The Competition Provider must then inform the individual(s) affected by the decision and, if required, take steps to recover prizes or awards made to the athlete(s). The Referee's decision shall be final.
- (vi) Fell, Hill and Mountain Running: If the results are not available at the conclusion of the event, then such a protest may be made at any time up until one week after the publication of the results. In such cases the protest should be made to the Competition Provider and/or the Referee. If, as a result of a protest under (2)(i) or (2)(ii) above, a runner is disqualified or the race result otherwise altered, the Competition Provider must then inform the individual(s) affected by the decision and, if required, take steps to recover

prizes or awards made to the athlete(s). The Competition Provider's / Referee's decision shall be final.

(3) Misconduct relating to competition

In the event of a matter of misconduct being reported to a National Association in accordance with rule 145 the National Association shall form an Investigatory Panel to review the matter and determine what penalties are enforced in accordance with Rule 145. They must have completed their investigation within a month of its referral to them.

(4) Further appeal to UKA in relation to competition matters

Any competitor, team or Club may appeal against the decision of a National Association. Notice of Appeal must be sent to UKA within 14 days of receipt of such decision and must be accompanied by a deposit of £50, which will be refundable at the discretion of UKA. In addition the board of UKA, may at its discretion, refer any decision taken by a National Association, and after consultation with the National Association, to an Independent Appeals Panel. Any other disciplinary matters that are not related to competition must be dealt with by policies and procedures outside the Competition Rule Book. The Appeal will be determined in accordance with the procedures established by UKA.

Without prejudice to the foregoing, where any competitor, team or club wishes to appeal any decision reached under (1) and (3) above it may seek resolution in accordance with the Appeal Procedure established by UKA. Any application for such an appeal must be received within 2 weeks of the date of the event or of the decision being contested or from a related decision made by a National Governing Body being published. UKA shall convene a Hearing within 4 weeks of receipt of the Notice of Appeal and shall notify all parties deemed to be involved in the Appeal. No new evidence will be accepted by UKA that has not been submitted previously to the Associations concerned. The hearing shall be conducted by an independent panel of three persons for that purpose. No member of the panel shall have any connection with any of the parties involved in the dispute or any vested interest in the outcome. The decision of the panel shall be final in accordance with UKA's jurisdiction. Appeals in

accordance with this provision are limited to those relating to Qualification to Compete and Misconduct only.

For the avoidance of doubt Appeals concerning any matters not relating to Competition are matters solely within the jurisdiction of National Associations and UKA and will be dealt with in accordance with their published procedures.

RULE 147 MIXED COMPETITION

1. Universal competitions such as relays or other team events in which men and women compete together or events in which men and women compete for a single classification are permitted in accordance with the applicable regulations of the relevant body.
2. Other than under Rule 147.1 for all other competitions held completely in the stadium, mixed events between male and female participants shall not normally be permitted.

However, mixed stadium competition in Field Events and in races of 5000m or longer may be permitted in all competitions except those held under Rules 1.1(a) to (h). In the case of competitions held under Rules 1.1(i) and (j) such mixed competition shall be allowed in a particular competition if specifically permitted by the relevant Area Association.

Note (i): For Mixed Competitions conducted in Field Events, separate result cards shall be used and results declared for each sex. For races, the sex of each athlete shall be shown in the result.

Note (ii): Mixed Competitions in Track Events as permitted under this Rule shall be conducted only where there are insufficient athletes of one or both sexes competing to justify the conduct of separate races.

Note (iii): Mixed Competitions in Track Events shall not, in any case, be conducted so as to allow athletes of one sex to be paced or assisted by athletes of another sex.

The intent of Rule 147.2 is to facilitate the conduct of Field Events and in races of 5000m or longer, when small numbers of athletes of one or both sexes are entered in the case of longer events (i.e. a track race walk

of 10,000m or more), where timetabling constraints make it difficult to program separate races. The intent of the Rule is not to provide opportunity for women to compete in races against men to achieve potentially better performance conditions.

To be clear, mixed competition in Field Events and in races of 5000m or longer is:

(a) permitted in all national competitions, subject only to the rules of the applicable federation. [No additional permission from an Area Association is required];

(b) permitted in a competition held under Rules 1.1(i) and (j) if specifically permitted by the relevant Area Association;

(c) not permitted in a competition held under Rules 1.1(a) to (h).

In the case of mixed competition in Vertical Jumps, Rules 181 to 183 must be strictly applied - including that the bar must continue to be raised in accordance with a single set of agreed increments for the entire competition.

There are also restrictions on the recognition of World Records in mixed competitions – see Rules 260.1 (with reference to track races of 5000m and longer) and 261 (with reference to women's road races). Rule 261 Note (ii) provides guidance on how a women's only race can be achieved (enabling a women's only record to be set) in a situation where both men and women are or might be competing.

[See also Rules 132.2 and 132.3]

RULE 147 S 1 UKA SUPPLEMENT MIXED COMPETITION

For competitions held entirely within the stadium, mixed events between male and female athletes shall be permitted in field events and mixed graded track races shall be permitted for Under 17, Under 20 and Senior age groups, subject to any limitations regarding distances that may be permitted.

Note: Performances achieved in mixed track races will not be valid as qualifying times for major events and Championships, nor National Records identified in Rule 264 S1.

Mixed road walking competitions between male and female participants of the same age group shall be permitted for Club, Inter-Club and open events. Mixed competitions may also be held in National or UKA

Championships but only where the number of participants make it impracticable to stage two separate races.

RULE 148 SURVEYING AND MEASUREMENTS

1. The accuracy of the markings and installations for athletics facilities under Rule 140 and Rule 149.2 shall be checked by an appropriately qualified surveyor who shall furnish appropriate certificates together with details of any check measurements made to the relevant body and/or the facility owner or operator. He shall be given full access to stadium plans and drawings and the latest measurement report for the purpose of this verification.
2. For Track and Field Events in competitions under Rules 1.1(a), (b), (c) and (f), all measurements shall be made with a calibrated steel tape or bar or with a scientific measuring device. The steel tape, bar or scientific measuring device shall be manufactured and calibrated according to international standards. The accuracy of the measuring equipment used in the competition shall have been verified by an appropriate organisation accredited by the national measurement authority.

At competitions other than those held under Rules 1.1(a), (b), (c) and (f), fibreglass tapes may also be used.

Note: Concerning acceptance of Records, see Rule 260.17(a).

RULE 149 VALIDITY OF PERFORMANCES

1. No performance accomplished by an athlete will be valid unless it is accomplished during an official competition organised in conformity with the Rules.
2. Performances in events normally conducted in the stadium, made outside traditional athletics facilities (such as those held in town squares, other sporting facilities, beaches, etc.) or on temporary facilities built within a stadium shall be valid and recognised for all purposes, if they are made subject to all of the following conditions:
 - (a) the relevant governing body as provided in Rules 1 to 3 has issued a permit for the event;
 - (b) a qualified panel of National Technical Officials are appointed to and officiate at the event;
 - (c) where applicable, equipment and implements in conformity

- with the Rules are used; and
- (d) the event is conducted in a competition area or facility in conformity with the Rules and in respect of which a survey has been made in accordance with Rule 148 on the day of the event.

Note: The current standard forms required to be used for reporting on the conformity of the competition area or facility are available from the IAAF Office, or may be downloaded from the IAAF website.

When a competition described in 149.2 is held over more than one day, the survey should be made on the day of the first event. In either case if the surveyor can be satisfied that there will be no movement or alteration to the facilities being surveyed, the survey may be completed up to two days prior to the day of the first event.

3. Performances made in accordance with these Rules in Qualification Rounds, in deciding ties in High Jump and Pole Vault, in any event or part of an event which is subsequently decreed void under the provisions of Rules 125.7, 146.4(b), 163.2 or 180.20 or in individual events in Combined Events competitions, regardless of whether or not the athlete completes the whole Combined Events competition, will normally be regarded as valid for purposes such as statistics, records, rankings and the achievement of entry standards.

The IAAF has exceptionally determined that solely for the purpose of determining whether an athlete has achieved the entry standard for a Combined Events competition:

“The conditions shall have been complied with in each of the individual events, except that, in events where wind velocity is measured, at least one of the following conditions shall be satisfied:

- (a) The velocity in any individual event shall not exceed plus 4 metres per second.
- (b) The average velocity (based on the algebraic sum of the wind velocities, as measured for each individual event, divided by the number of such events) shall not exceed plus 2 metres per second.”

RULE 150 VIDEO RECORDING

In competitions held under Rules 1.1(a), (b) and (c) and, whenever possible, in other competitions, an official video recording of all events to the satisfaction of the Technical Delegate(s) shall be made. It should be sufficient to support the role of the Video Referee when appointed and in other situations to demonstrate the accuracy of performances and any violation of the Rules.

Specific information is provided in the IAAF Video Recording and Video Referee Guidelines, which may be downloaded from the IAAF website.

The appointment at any competition of a Video Referee will significantly affect the practical oversight of many aspects of those competitions at which sufficient video collection and replay systems are available.

The Video Referee will generally be able to act proactively in respect of the track events (e.g. the start, running inside the lane line around the curve, jostling and obstruction, breaking from lanes too early, relay changeovers). If the amount of cameras and equipment is sufficient to play a similar role for some or all of the field events, he can undertake a similar role, but usually in a more reactive fashion when the on-field Referee requests further examination or review of a specific incident.

In the case of the Track Events, the Video Referee will observe the races on one or more screens in the video room and then based on either his own observations or upon referral from a Referee or Chief Umpire in the competition area, examine one or more particular issue by looking at any replayed footage that might be available. If it is clear as a result that there has been an infringement of the Rules, then he should take the appropriate decision and convey it to the Track Referee and the Chief Photo Finish Judge. Similarly, if an Umpire or trackside Referee has reported a potential infringement, it should be checked by the Video Referee and the appropriate advice provided and decision taken.

In addition, official video footage will as in the past continue to be used to assist in dealing with protests and appeals.

It is becoming common for experienced companies to provide an existing service for competitions rather than Organisers setting up their own. However, either option can be used.

RULE 151 SCORING

In a match where the result is to be determined by the scoring of points, the method of scoring shall be agreed by all the competing Members or teams before the start of the match, unless provided for in the applicable regulations.

SECTION III – TRACK EVENTS

Rules 163.2, 163.6 (except under Rules 230.12 and 240.9), 163.14, 164.2, 165 and 167.1 also apply to Sections VII, VIII, and IX.

RULE 160 TRACK MEASUREMENTS

1. The length of a standard running track shall be 400m. It shall consist of two parallel straights and two bends whose radii shall be equal. The inside of the track shall be bordered by a kerb of suitable material that should be coloured white, with a height of 50mm to 65mm and a width of 50mm to 250mm. The kerb on the two straights may be omitted and a white line 50mm wide substituted.

If a section of the kerb on a bend has to be temporarily removed for Field Events, its place on the surface beneath shall be marked with a white line 50mm in width and by cones or flags, minimum height 0.15m, placed on the white line so that the edge of the base of the cone or flag pole coincides with the edge of the white line closest to the track, and placed at intervals not exceeding 4m. (Flags shall be placed at an angle of 60° with the ground away from the track.) This (including also the option of temporary kerbing) shall also apply to the curved section of the steeplechase track where athletes divert from the main track to negotiate the water jump, to the outer half of the track in the case of starts according to Rule 163.5(b) and, optionally, to the straights, in this latter case, at intervals not exceeding 10m.

Note: All points at which the track changes from a curve to a straight or a straight to a curve shall be marked, in a distinctive colour 50mm x 50mm on the white line, by the surveyor and a cone placed at such points during a race.

- The measurement shall be taken 0.30m outward from the kerb or, where no kerb exists on a bend (or the diversion from the track for the steeplechase water jump), 0.20m from the line marking the inside of the track.

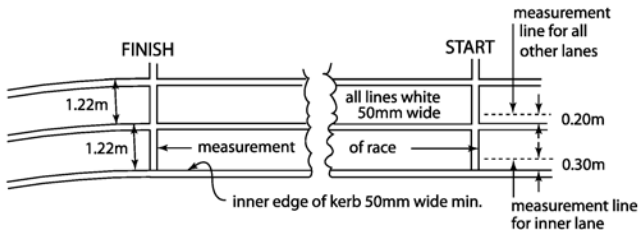

[Figure 160 - Track measurements (infield View)]

- The distance of the race shall be measured from the edge of the start line farther from the finish to the edge of the finish line nearer to the start.
- In all races up to and including 400m, each athlete shall have a separate lane, with a width of $1.22\text{m} \pm 0.01\text{m}$, including the lane line on the right, marked by white lines 50mm in width. All lanes shall be of the same nominal width. The inner lane shall be measured as stated in Rule 160.2, but the remaining lanes shall be measured 0.20m from the outer edges of the lines.

Note: For all tracks constructed before 1 January 2004 for all such races, the lane may have a width of maximum 1.25m. However, when such a track is fully resurfaced, the lane width shall comply with this Rule.

- In International Competitions under Rules 1.1(a), (b), (c) and (f), the track should allow for eight lanes minimum.
- The lateral inclination of tracks towards the inside edge should not exceed 1:100 (1%) unless special circumstances exist which justify the IAAF providing an exemption, and the overall downward inclination in the running direction shall not exceed 1:1000 (0.1%).
- Full technical information on track construction, layout and marking is contained in the IAAF Track and Field Facilities Manual. This Rule gives basic principles, which must be followed.

Colours to use for marking the track are indicated on the Track Marking Plan included in the IAAF Track and Field Facilities Manual.

RULE 160 S 1 UKA SUPPLEMENT TRACK MEASUREMENTS

The inside of the track should be bordered by a kerb of suitable material, approximately 5cm in width. The kerb on the two straights may be omitted and a white line 5cm wide substituted.

- (1) It is recommended that the direction of running shall be left hand inside.
- (2) For Championships or for any recognised National record to be accepted, the track must have been measured for distance either:-
 - (i) 30cm outwards from the outer edge of the kerbing if there is a raised border.
 - or
 - (ii) 20cm from the outer edge of the line if there is no raised border. In this case cones must be placed on the white line so that the base of the cone coincides with the outer edge of the inside line to prevent any athlete running on the lane line itself. These cones shall be no more than 4 metres apart and preferably closer to each other.

The measurement 20cm from the outer edge of the line also applies to that section of a steeplechase course where athletes divert from the main track to negotiate the water jump.

NOTE: If a track has been measured and certificated as under 3(a) above and the kerbing is subsequently removed around any bend or bends the distances run by athletes using the inside lane, including those in middle distance races, will not be accurate. A performance set under these circumstances will not be acceptable as a qualifying standard for major International Championships or as a UK record.

- (3) In measuring lanes for distance the inner lane shall be measured as stated in (3) above and the other lanes 20cm from the outer edge of each subsequent lane line.
- (4) Races up to 100 metres must be run on a straight course so as to allow a separate lane for each competitor.
- (5) Individual races up to and including 400 metres should be run in lanes with a separate lane for each competitor.

- (6) Races over 400 metres and up to and including 800 metres may be run in lanes as far as the end of the first bend.

RULE 161 STARTING BLOCKS

1. Starting blocks shall be used for all races up to and including 400m (including the first leg of the 4 × 200m, the Medley Relay and 4 × 400m) and shall not be used for any other race. When in position on the track, no part of the starting block shall overlap the start line or extend into another lane, with the exception that, provided there is no obstruction to any other athlete, the rear part of the frame may extend beyond the outer lane line.
2. Starting blocks shall comply with the following general specifications:
 - (a) The starting blocks shall consist of two foot plates, against which the athlete's feet are pressed in the starting position and which shall be mounted on a rigid frame. They shall be entirely rigid in construction and shall give no unfair advantage to the athlete. The frame shall in no way obstruct the athlete's feet as they leave the blocks.
 - (b) The foot plates shall be sloped to suit the starting position of the athlete, and may be flat or slightly concave. The surface of the foot plates shall accommodate the spikes in the athlete's shoes, either by using slots or recesses in the face of the foot plate or by covering the surface of the foot plate with suitable material permitting the use of spiked shoes.
 - (c) The mounting of the foot plates on the frame may be adjustable, but it shall allow no movement during the actual start. In all cases, the foot plates shall be adjustable forward or backward in relation to each other. The adjustments shall be secured by firm clamps or a locking mechanism, which can be easily and quickly operated by the athlete.
 - (d) They shall be fixed to the track by a number of pins or spikes, arranged to cause the minimum possible damage to the track. The arrangement shall permit the starting blocks to be quickly and easily removed. The number, thickness and length of pins or spikes depend on the track construction. The anchorage shall permit no movement during the actual start.

- (e) When an athlete uses his own starting blocks, they shall comply with these Rules but otherwise may be of any design or construction, provided that they do not interfere with other athletes.
- 3. In competitions held under Rules 1.1(a), (b), (c) and (f) and for any performances submitted for ratification as a World Record under Rules 261 or 263, the starting blocks shall be linked to an IAAF certified Start Information System. This system is strongly recommended for other competitions.

Note: In addition, an automatic recall system, within the Rules, may also be used.

- 4. In competitions held under Rules 1.1(a) to (f), athletes shall use starting blocks provided by the Organisers of the competition. In other competitions on synthetic surfaced tracks the Organisers may insist that only starting blocks provided by them may be used.

This Rule should also be interpreted so that:

- (a) no part of the frame or footplates can overlap a starting line;
- (b) the frame only (but not any part of the footplate) can extend into the outer lane provided there is no obstruction. This reflects the long standing practice of athletes at the start of races on a bend placing their blocks at an angle to run the most direct line after the start.

The use of lights, by deaf or hearing impaired athletes only, at the start of races is allowed and is not considered assistance. It should however be the obligation of the athlete or his team for the financing and supply of such equipment and its compatibility with the start system in use, unless at a particular meeting where there is an appointed technical partner who can provide it.

RULE 161 S 1 UKA SUPPLEMENT STARTING BLOCKS

The use of starting blocks is optional, except where blocks incorporating false start detection equipment are in use when all competitors shall be required to use only the starting blocks provided. If false start detection equipment is not in use, athletes may use their own starting blocks but such starting blocks must be approved by the Starter.

For the avoidance of doubt in races up to and including 400m if the use of starting blocks is not compulsory (except as defined in Rule 161) then a crouch start does not have to be applied.

NOTE: On synthetic surfaced tracks the Competition Provider may insist that only starting blocks provided by them shall be used.

RULE 162 THE START

1. The start of a race shall be denoted by a white line 50mm wide. In all races not run in lanes, the start line shall be curved, so that all the athletes start the same distance from the finish. Starting positions in events at all distances shall be numbered from left to right, facing the direction of running.

Note (i): In the case of events starting outside the stadium, the start line may be up to 0.30m in width and may be of any colour contrasting distinctively with the surface of the start area.

Note (ii): The 1500m start line, or any other curved start line, may be extended out from the outside lane to the extent that the same synthetic surface is available.

It is anticipated that, in order to efficiently complete the start procedures and for larger meetings to appropriately introduce the competitors in the race the athletes, when assembled, should be standing and facing in the direction of the race.

2. At all International Competitions, except as noted below, the commands of the Starter shall be given in his own language, in English or in French.
 - (a) In races up to and including 400m (including 4 × 200m, the Medley Relay as defined in Rule 170.1 and 4 × 400m), the commands shall be "On your marks" and "Set".

- (b) In races longer than 400m (except 4 × 200m, the Medley Relay and 4 × 400m), the command shall be "On your marks".
- (c) In any race when, under Rule 162.5, the Starter is not satisfied that all is ready for the start to proceed after the athletes are on their marks or he otherwise aborts the Start, the command shall be "Stand up".

All races shall normally be started by the report of the Starter's gun held upwards.

Note: In competitions under Rules 1.1(a), (b), (c), (e) and (i), the commands of the Starter shall be given in English only.

The Starter must not initiate the start procedures before he is sure that the relevant timing team is ready as well as the Judges at the finish and in races up to and including 200m, the Wind Gauge Operator. The communication process between the start and the finish area and the timing team varies according to the level of the competition. In events organised under Rules 1.1(a) to (f) and many other high level meetings there is invariably a service company responsible for the electronic timing and the Start Information System. In this case, there will be technicians who are responsible for communication. In other competitions a variety of communication systems are used – radios, phones, or by using flags or flashing lights.

3. In races up to and including 400m (including the first leg of 4 × 200m, the Medley Relay and 4 × 400m), a crouch start and the use of starting blocks are compulsory. After the "On your marks" command, an athlete shall approach the start line, assume a position completely within his allocated lane and behind the start line. An athlete shall not touch either the start line or the ground in front of it with his hands or his feet when on his mark. Both hands and at least one knee shall be in contact with the ground and both feet in contact with the foot plates of the starting blocks. At the "Set" command, an athlete shall immediately rise to his final starting position retaining the contact of the hands with the ground and of the feet with the foot plates of the blocks. Once the Starter is satisfied that all athletes are steady in the "Set" position, the gun shall be fired.

In all races using a crouch start, as soon as they are steady in their blocks, the Starter shall raise his arm in which he holds the gun, then he shall say "Set". He shall wait then for all the athletes to be steady and shall then fire the gun.

The Starter must not raise his arm too early, especially when manual Timekeepers are being used. He is advised to raise his arm only when he feels he is about to give the command "Set".

There is no rule that enables to determine the time that elapses between the commands "On your marks" and "Set" on one hand, and on the other hand, between the command "Set" and the gun shot. The Starter shall let the athletes go once they are all motionless in the correct starting position. Which means that he may have, for certain starts, to fire the gun quite quickly, but on the other hand, he may also have to wait longer in order to make sure that they are all steady in their starting position.

4. In races longer than 400m (except $4 \times 200\text{m}$, the Medley Relay and $4 \times 400\text{m}$), all starts shall be made from a standing position. After the "On your marks" command, an athlete shall approach the start line and assume a starting position behind the start line (completely within his allocated lane in races started in lanes). An athlete shall not touch any part of the ground with his hand or hands and/or the start line or the ground in front of it with his feet when on his mark. Once the Starter is satisfied that all athletes are steady in the correct starting position, the gun shall be fired.
5. On the command "On your marks" or "Set", as the case may be, all athletes shall, at once and without delay, assume their full and final starting position. If, for any reason, the Starter is not satisfied that all is ready for the start to proceed after the athletes are on their marks, he shall order all athletes to withdraw from their marks and the Starter's Assistants shall assemble them again (See also Rule 130).
Where an athlete in the judgement of the Starter,
 - (a) after the command "On your marks" or "Set", and before the report of the gun, causes the start to be aborted, for instance by raising a hand and/or standing or sitting up in the case of a crouch start, without a valid reason, (such reason to be evaluated by the relevant Referee); or

- (b) fails to comply with the commands “On your marks“ or “Set“ as appropriate, or does not place himself in his final starting position at once and without delay; or
- (c) after the command “On your marks“ or “Set” disturbs other athletes in the race through sound, movement or otherwise, the Starter shall abort the start.

The Referee may warn the athlete for improper conduct (disqualify in case of a second infringement of the Rule during the same competition), according to Rules 125.5 and 145.2. A green card shall not be shown. However, when an extraneous reason was considered to be the cause for aborting the start, or the Referee does not agree with the Starter’s decision, a green card shall be shown to all the athletes to indicate that a false start was not committed by any athlete.

The division of the start Rules into disciplinary matters (under Rule 162.5) and false starts (Rules 162.7 and 162.8) ensures that the whole field was not penalised for the actions of a single athlete. It is important in order to maintain the integrity of the intention of this division and that Starters and Referees are as diligent in the application of Rule 162.5 as well as in detecting false starts.

Such conduct, whether wilful or unintentional perhaps through nervousness should cause Rule 162.5 to be applied although where the Starter is of the view that it was unintentional, the application of Rule 162.2(c) only may be appropriate.

Conversely, there will be instances in which an athlete is entitled to request a delay of the start for legitimate reasons. It is therefore vital that the Start Referee (in particular) pays attention to the environment and conditions surrounding the start, especially in relation to factors of which the Starter may not be aware because he is focussing on preparing himself for the start and/or wearing headphones.

In all such cases the Starter and Referee must act reasonably and efficiently and clearly indicate their decisions. If appropriate the reasons for the decisions can be announced to the athletes in the race and if possible or desirable also to the announcers, television team etc. through the communication network.

A green card shall not be shown in any case when a yellow or red card has been issued.

False Start

6. When an IAAF certified Start Information System is in use, the Starter and/or an assigned Recaller shall wear headphones in order to clearly hear the acoustic signal emitted when the System indicates a possible false start (i.e. when the reaction time is less than 0.100 second). As soon as the Starter and/or assigned Recaller hears the acoustic signal, and if the gun was fired, there shall be a recall and the Starter shall immediately examine the reaction times and other available information from the Start Information System in order to confirm which, if any, athlete(s) is/are responsible for the recall.

Note: When an IAAF certified Start Information System is in operation, the evidence of this equipment shall be used as a resource by the relevant Officials to assist in making a correct decision.

7. An athlete, after assuming a full and final starting position, shall not commence his start until after receiving the report of the gun. If, in the judgement of the Starter (including under Rule 129.6), he does so any earlier, it shall be a false start.

Note (i): Any motion by an athlete that does not include or result in the athlete's foot / feet losing contact with the foot plate(s) of the starting blocks, or the athlete's hand / hands losing contact with the ground, shall not be considered to be the commencement of his start. Such instances may, if applicable, be subject to a disciplinary warning or disqualification.

However, if the Starter determines that prior to receiving the report of the gun an athlete initiated a movement that was not stopped and continued into the commencement of his start, it shall be a false start.

Note (ii): As athletes starting races in a standing position are more prone to over-balance, if such a movement is considered to be accidental, the start should be regarded as "unsteady". If an athlete is pushed or jostled over the line before the start, he should not be penalised. Any athlete causing such interference may be subject to a disciplinary warning or disqualification.

Generally no false start should be charged if the athlete has not lost contact with the ground or foot plates. For example, if an athlete moves his hips up, but then moves them down without his hands or feet losing contact with the ground or foot plates at any time, it should not result in a false start. It may be a reason to warn (or disqualify if there has been a previous warning) the athlete for improper conduct under Rule 162.5. However in cases of a “rolling start” where the Starter (or Recaller) is of the opinion that an athlete has effectively anticipated the start through some continuous movement even if he did not move his hands or feet before the gun sounded, the race should be recalled. This can be done by a Starter or Recaller but it will be the Starter who is in the best situation to judge such a case as only he will know the position of his finger on the gun trigger when the athlete began his movement. In these cases where the Starter is sure that the athlete’s movement began before the report of the gun, a false start should be awarded.

In accordance with Note (ii) Starters and Referees should avoid being over-zealous in the application of Rule 162.7 to those events started from a standing position. Such instances are rare and usually occur unintentionally as it is easier to overbalance from a two-point start. It is not intended that same should be unduly penalised.

If such a movement was considered to be accidental, Starters and Referees are encouraged to first consider calling the start “unsteady” and proceed according to Rule 162.2(c). However repeat practices during the same event may entitle the Starter and/or Referee to consider applying either the false start or disciplinary procedures, as might best be applicable in the situation.

8. Except in Combined Events, any athlete responsible for a false start shall be disqualified by the Starter.

For Combined Events, see Rule 200.8(c).

Note: In practice, when one or more athletes make a false start, others are inclined to follow and, strictly speaking, any athlete who does so has also made a false start. The Starter should warn or disqualify only such athlete or athletes who, in his opinion, were responsible for the false start. This may result in more than one athlete being warned or disqualified. If the false start is not due to any athlete, no warnings shall be given and a green card shall be shown to all the athletes.

9. In case of a false start, the Starter's Assistants shall proceed as follows:

Except in Combined Events, the athlete(s) responsible for the false start shall be disqualified and a red and black (diagonally halved) card shall be raised in front of him.

In Combined Events, in case of a first false start, the athlete(s) responsible for the false start shall be warned with a yellow and black (diagonally halved) card raised in front of him. At the same time, all the other athletes taking part in the race shall be warned with the yellow and black card raised in front of them by one or several Starter's Assistants in order to notify them that anyone committing further false starts will be disqualified. In case of further false starts, the athlete(s) responsible for the false start shall be disqualified and the red and black card shall be raised in front of him.

If lane markers that provide for it are being used, then whenever a card is shown to the athlete(s) responsible for the false start, the corresponding indication should be shown on the lane marker(s).

It is recommended that the size of the diagonally halved cards be A5 and that they be doubled sided. Note that the corresponding indication on the lane marker(s) may remain yellow and red as previously, in order to avoid unnecessary expense in modifying existing equipment.

10. The Starter or any Recaller, who is of the opinion that the start was not a fair one, shall recall the athletes by firing a gun.

The reference to a fair start does not relate solely to cases of a false start. This rule should also be interpreted as applying to other situations such as blocks slipping, a foreign object interfering with one or more athletes during a start etc.

RULE 162 S 1 UKA SUPPLEMENT THE START

Under 13, Under 15 and Masters' and Schools' Under 17 Age Groups

In all competitions other than those where younger athletes are competing in a competition where Rule 162(6) above applies, whether false start

detection equipment is in use or not, any athlete deemed responsible for a false start shall be warned. An athlete deemed responsible for two false starts shall be disqualified.

If in the opinion of the Starter, or the Start Recaller, the start was not fair, the competitors must be recalled with a second signal. If the Starter decides that the unfair start was due to one or more competitors 'beating the start signal' it shall be considered a false start.

NOTE: In practice, when one or more competitors beat the start signal others are inclined to follow and strictly speaking, any competitor who does so has beaten the start signal. The Starter should warn (or disqualify) as appropriate, only such competitor or competitors who in his or her opinion were responsible for beating the start signal. If the unfair start is not due to any competitor no warning shall be given.

In the case of athletes competing in a Combined Events competition as defined in Rule 200 for the age groups identified in the previous paragraph, whether false start detection equipment is in use or not, any athlete deemed responsible for a false start shall be warned. Any athlete(s) responsible for three false starts shall be disqualified from the race.

RULE 163 THE RACE

1. In races including at least one bend, the direction of running and walking shall be left-hand inside. The lanes shall be numbered with the left-hand inside lane numbered 1.

Where conditions permit and the track is properly surveyed, straight events can be conducted in the opposite direction, i.e. right-hand inside.

Obstruction

2. If an athlete is jostled or obstructed during an event so as to impede his progress, then:
 - (a) if the jostling or obstruction is considered unintentional or is caused otherwise than by an athlete, the Referee may, if he is of the opinion that an athlete (or his team) was seriously affected,

in accordance with Rule 125.7 or Rule 146.4, order that the race (for one, some or all of the athletes) be re-held or allow the affected athlete (or team) to compete in a subsequent round of the event;

- (b) if another athlete is found by the Referee to be responsible for the jostling or obstruction, such athlete (or his team) shall be liable to disqualification from that event. The Referee may, if he is of the opinion that an athlete (or his team) was seriously affected, in accordance with Rule 125.7 or Rule 146.4, order that the race (for one, some or all of the athletes) be re-held excluding any disqualified athlete (or team) or allow any affected athlete (or team) (other than any disqualified athlete or team) to compete in a subsequent round of the event.

Note: In cases considered serious enough, Rule 125.5 and 145.2 may also be applied.

In both cases Rule 163.2(a) and (b), such athlete (or team) should normally have completed the event with bona fide effort.

Lane Infringement

3. (a) In all races run in lanes, each athlete shall keep within his allocated lane from start to finish. This shall also apply to any portion of a race run in lanes.
- (b) In all races (or any part of races) not run in lanes, an athlete running on a bend, on the outer half of the track as per Rule 163.5(b), or on any curved part of the diversion from the track for the steeplechase water jump, shall not step or run on or inside the kerb or line marking the applicable border (the inside of the track, the outer half of the track, or any curved part of the diversion from the track for the steeplechase water jump).

Except as stated in Rule 163.4, if the Referee is satisfied, on the report of a Judge or Umpire or otherwise, that an athlete has infringed this Rule, he shall be disqualified.

4. An athlete shall not be disqualified if he
 - (a) is pushed or forced by another person to step or run outside his lane or on or inside the kerb or line marking the applicable border, or

- (b) steps or runs outside his lane in the straight, any straight part of the diversion from the track for the steeplechase water jump or outside the outer line of his lane on the bend, with no material advantage thereby being gained and no other athlete being jostled or obstructed so as to impede his progress. If material advantage is gained, the athlete shall be disqualified.

Note: Material advantage includes improving his position by any means, including removing himself from a “boxed” position in the race by having stepped or run inside the inside edge of the track.

This Note specifically outlaws the practice of an athlete seeking to improve his position in races by moving onto the inside of the track (whether intentionally or after being pushed or jostled there by another athlete) to get out of a boxed position by running on the inside until clear. Whilst normally running on the inside of lane 1 in the straight (as distinct from doing so on the bend) would not lead to mandatory disqualification, the Referee now has the power to disqualify in his discretion if this occurs and the athlete is advantaged even if the initial reason for being there was the result of being pushed or jostled. In such cases the athlete should take immediate steps to return to the track without seeking or gaining any advantage.

RULE 163 S 1 UKA SUPPLEMENT RUNNING ON THE LINE

If the Referee considers that such action is unintentional, he or she may, at his or her discretion, disqualify if of the opinion that a material advantage was gained thereby. (The table below may be used for guidance in determining the advantage gained).

Track 400 m Stride 2.30 m	Advantage Gained by Encroaching <i>t</i> cm on Inside of Lane			
Number of Strides	<i>t</i> = 50 mm	<i>t</i> = 100 mm	<i>t</i> = 150 mm	<i>t</i> = 300 mm
	mm	mm	mm	mm
1	4	7	11	22
2	7	14	22	44
3	11	22	33	66
4	14	29	44	88
5	18	36	54	109
6	22	44	65	131
7	25	51	76	153
8	29	58	87	175
9	33	65	98	197
10	36	72	109	219

This table shows, mathematically, the theoretical advantage gained by taking from 1 to 10 strides inside the inner border of a lane, The distances are shown in millimetres, e.g. four strides 150 mm inside gives an advantage of 44 mm.

5. In competitions held under Rule 1.1 and where suitable in other competitions:

- (a) the 800m event shall be run in lanes as far as the nearer edge of the breakline where athletes may leave their respective lanes. The breakline shall be an arced line marked after the first bend, 50mm wide, across all lanes other than lane 1. To assist athletes identify the breakline, small cones, prisms or other suitable markers, 50mm × 50mm and no more than 0.15m high, preferably of different colour from the breakline and the lane lines, shall be placed on the lane lines immediately before the intersection of the lane lines and the breakline.

Note: In competitions under Rules 1.1(d) and (h), the participating teams may agree not to use lanes.

- (b) when there are more than 12 athletes in a race over 1000m, 2000m, 3000m, 5000m or 10,000m, they may be divided into two groups with one group of approximately two thirds of the athletes on the regular arced start line and the other group on a separate arced start line marked across the outer half of the track. The other group shall run as far as the end of the first bend of the race on the outer half of the track, which shall be marked by cones, flags or temporary kerbing as described in Rule 160.1. The separate arced start line shall be positioned in such a way that all the athletes shall run the same distance.

The breakline for 800m indicates where the athletes in the outer group in 2000m and 10,000m may join the athletes using regular start.

For group starts in 1000m, 3000m and 5000m, the track shall be marked at the beginning of the finish straight to indicate where athletes starting in the outer group may join the athletes using the regular start. This mark may be a 50mm × 50mm mark on the line between lanes 4 and 5 (lanes 3 and 4 in a six-lane track) immediately before which a cone or flag is placed until the two groups converge.

- (c) If an athlete does not follow this Rule he, or in the case of a relay his team, shall be disqualified.

Leaving the Track

6. An athlete, after voluntarily leaving the track, shall not be allowed to continue in the race and shall be recorded as not finishing the event. Should the athlete attempt to re-enter the race, he shall be disqualified by the Referee.

Check-Marks

7. Except as stated in Rule 170.4, when all or the first portion of a Relay Race is being run in lanes, athletes may not make check-marks or place objects on or alongside the running track for their assistance. The Judges shall direct the relevant athlete to adapt or remove any marks or objects not complying with this Rule. If he does not, the Judges shall remove them.

Note: Serious cases may further be dealt with under Rule 125.5 and 145.2

Wind Measurement

8. All wind gauge equipment shall be manufactured and calibrated according to international standards. The accuracy of the measuring equipment used in the competition shall have been verified by an appropriate organisation accredited by the national measurement authority.
9. Non-mechanical wind gauges shall be used at all International Competitions under Rules 1.1(a) to (h) and for any performance submitted for ratification as a World Record.
A mechanical wind gauge should have appropriate protection to reduce the impact of any crosswind. Where tubes are used, their length on either side of the measuring device should be at least twice the diameter of the tube.
10. The Track Referee shall ensure that the wind gauge for Track Events is placed beside the straight, adjacent to lane 1, 50m from the finish line. The measuring plane shall be positioned $1.22\text{m} \pm 0.05\text{m}$ high and not more than 2m away from the track.
11. The wind gauge may be started and stopped automatically and/or remotely, and the information conveyed directly to the competition computer.
12. The periods for which the wind velocity shall be measured from the flash / smoke of the Starter's gun are as follows:

	Seconds
100m	10 (Also to apply to all distances up to 100m)
100m Hurdles	13
110m Hurdles	13

In the 200m event, the wind velocity shall normally be measured for a period of 10 seconds commencing when the first athlete enters the straight.

- The wind gauge shall be read in metres per second, rounded to the next higher tenth of a metre per second, unless the second decimal is zero, in the positive direction (that is, a reading of +2.03 metres per second shall be recorded as +2.1; a reading of -2.03 metres per second shall be recorded as -2.0). Gauges that produce digital readings expressed in tenths of metres per second shall be constructed so as to comply with this Rule.

Indication of Intermediate Times

- Intermediate times and preliminary winning times may be officially announced and/or displayed. Otherwise, such times must not be communicated to the athletes by persons in the competition area without the prior approval of the appropriate Referee. This approval shall be given only when there are no time displays visible to athletes at the relevant point and in circumstances where such times will be provided to all athletes in the race.

Athletes who receive intermediate times that have been communicated in violation of this Rule shall be considered to have received assistance and shall be subject to the provisions of Rule 144.2.

Note: The competition area, which normally also has a physical barrier, is defined for this purpose as the area where the competition is being staged and which has an access restricted to the competing athletes and personnel authorised in accordance with the relevant Rules and Regulations.

Drinking / Spinging

- (a) In Track Events of 5000m or longer, the Organisers may provide water and sponges to athletes if weather conditions warrant such provision.

- (b) In Track Events longer than 10,000m, refreshments, water and sponging stations shall be provided. Refreshments may be provided either by the Organisers or the athlete and shall be placed so that they are easily accessible to, or may be put by authorised persons into the hands of, the athletes. Refreshments provided by the athletes shall be kept under the supervision of officials designated by the Organisers from the time that the refreshments are lodged by the athletes or their representatives. Those officials shall ensure that the refreshments are not altered or tampered with in any way.
- (c) An athlete who receives or collects refreshment or water from a place other than the official stations, except where provided for medical reasons from or under the direction of race officials, or takes the refreshment of another athlete, should, for a first such offence, be warned by the Referee normally by showing a yellow card. For a second offence, the Referee shall disqualify the athlete, normally by showing a red card. The athlete shall then immediately leave the track.

Note: An athlete may receive from or pass to another athlete refreshment, water or sponges provided it was carried from the start or collected or received at an official station. However, any continuous support from an athlete to one or more others in such a way may be regarded as unfair assistance and warnings and/or disqualifications as outlined above may be applied.

RULE 164 THE FINISH

1. The finish of a race shall be denoted by a white line 50mm wide.
Note: In the case of events finishing outside the stadium, the finish line may be up to 0.30m in width and may be of any colour contrasting distinctively with the surface of the finish area.
2. The athletes shall be placed in the order in which any part of their bodies (i.e. torso, as distinguished from the head, neck, arms, legs, hands or feet) reaches the vertical plane of the nearer edge of the finish line as defined above.
3. In any race decided on the basis of the distance covered in a fixed period of time, the Starter shall fire the gun exactly one minute

before the end of the race to warn athletes and Judges that the race is nearing its end. The Starter shall be directed by the Chief Timekeeper and, at exactly the appropriate time after the start, he shall signal the end of the race by again firing the gun. At the moment the gun is fired to signal the end of the race, the Judges appointed for that purpose shall mark the exact spot where each athlete touched the track for the last time before or simultaneously with the firing of the gun.

The distance achieved shall be measured to the nearest metre behind this mark. At least one Judge shall be assigned to each athlete before the start of the race for the purpose of marking the distance achieved.

Guidelines for the conduct of the One Hour Race may be downloaded from the IAAF website.

RULE 165 TIMING AND PHOTO FINISH

1. Three methods of timekeeping shall be recognised as official:
 - (a) Hand Timing;
 - (b) Fully Automatic Timing obtained from a Photo Finish System;
 - (c) Timing provided by a Transponder System for competitions held under Rules 230 (races not held completely in the stadium), 240, 250, 251 and 252 only.
2. Under Rule 165.1 (a) and (b), the time shall be taken to the moment at which any part of the body of an athlete (i.e. torso, as distinguished from the head, neck, arms, legs, hands or feet) reaches the vertical plane of the nearer edge of the finish line.
3. Times for all finishers shall be recorded. In addition, whenever possible, lap times in races of 800m and over and intermediate times at every 1000m in races of 3000m and over shall be recorded.

Hand Timing

4. The Timekeepers shall be in line with the finish and, where possible, they should be placed at least 5m from the outside lane of the track. In order that they may all have a good view of the finish line, an elevated stand should be provided.
5. Timekeepers shall use manually operated electronic timers with digital readouts. All such timing devices are termed "watches" for the purpose of the Rules.

6. The lap and intermediate times as per Rule 165.3 shall be recorded either, by designated members of the timekeeping team using watches capable of taking more than one time, or by additional Timekeepers, or by transponders.
7. The time shall be taken from the flash / smoke of the gun.
8. Three official Timekeepers (one of whom shall be the Chief Timekeeper) and one or two additional Timekeepers shall time the winner of every event and any performances for record purposes. (For Combined Events, see Rule 200.8(b).) The times recorded by the additional Timekeepers' watches shall not be considered unless one or more of the official Timekeepers' watches fail to record the time correctly, in which case the additional Timekeepers shall be called upon, in such order as has been decided previously, so that in all the races, three watches should have recorded the official winning time.
9. Each Timekeeper shall act independently and without showing his watch to, or discussing his time with, any other person, shall enter his time on the official form and, after signing it, hand it to the Chief Timekeeper who may examine the watches to verify the reported times.
10. For all hand-timed races, times shall be read and recorded as follows:
 - (a) For races on the track, unless the time is an exact 0.1 second, the time shall be converted and recorded to the next longer 0.1 second, e.g. 10.11 shall be recorded as 10.2.
 - (b) For races partly or entirely outside the stadium, unless the time is an exact whole second, the time shall be converted and recorded to the next longer whole second, e.g. 2:09:44.3 shall be recorded as 2:09:45.
11. If, after converting as indicated above, two of the three watches agree and the third disagrees, the time recorded by the two shall be the official time. If all three watches disagree, the middle time shall be official. If only two times are available and they disagree, the longer time shall be official.
12. The Chief Timekeeper, acting in accordance with the Rules mentioned above, shall decide the official time for each athlete and provide the results to the Competition Secretary for distribution.

Fully Automatic Timing and Photo Finish System

13. A Fully Automatic Timing and Photo Finish System complying with IAAF Rules should be used at all competitions.

The System

14. The system must have been tested, and have a certificate of accuracy issued within 4 years of the competition, including the following:
 - (a) The System must record the finish through a camera positioned in the extension of the finish line, producing a composite image.
 - (i) For competitions under Rule 1.1, this composite image must be composed of at least 1000 images per second.
 - (ii) For other competitions, this composite image must be composed of at least 100 images per second.In each case, the image must be synchronised with a uniformly marked time-scale graduated in 0.01 seconds.
 - (b) The System shall be started automatically by the Starter's signal, so that the overall delay between the report from the muzzle or its equivalent visual indication and the start of the timing system is constant and equal to or less than 0.001 second.
15. In order to confirm that the camera is correctly aligned and to facilitate the reading of the Photo Finish image, the intersection of the lane lines and the finish line shall be coloured black in a suitable design. Any such design must be solely confined to the intersection, for no more than 20mm beyond, and not extended before, the leading edge of the finish line. Similar black marks may be placed on each side of the intersection of an appropriate lane line and the finish line to further facilitate reading.
16. The placing of the athletes shall be identified from the image by means of a cursor with its reading line guaranteed to be perpendicular to the time scale.
17. The System must automatically determine and record the finish times of the athletes and must be able to produce a printed image which shows the time of any athlete. Additionally, the system shall provide a tabular overview which shows the time or other result of every athlete. Subsequent changes of automatically determined values and manual input of values (such as start time, finish time), shall be indicated by the system automatically in the time scale of the printed image and the tabular overview.

18. A system which operates automatically at either the start or the finish, but not at both, shall be considered to produce neither Hand nor Fully Automatic Times and shall not therefore be used to obtain official times. In this case, the times read on the image will not, under any circumstances, be considered as official, but the image may be used as a valid support in order to determine placings and adjust time intervals between athletes.

Note: If the timing mechanism is not started by the Starter's signal, the time-scale on the image shall indicate this fact automatically.

Operation

19. The Chief Photo Finish Judge shall be responsible for the functioning of the System. Before the start of the competition, he will meet the technical staff involved and familiarise himself with the equipment, checking all applicable settings.

In cooperation with the Track Referee and the Starter, he shall initiate a zero control test, before the beginning of each session, to ensure that the equipment is started automatically by the Starter's signal within the limit identified in Rule 165.14(b) (i.e. equal to or less than 0.001 second).

He shall supervise the testing of the equipment and ensure that the camera(s) is (are) correctly aligned.

20. There should be at least two photo finish cameras in action, one from each side. Preferably, these timing systems should be technically independent, i.e. with different power supplies and recording and relaying of the Starter's signal, by separate equipment and cables.

Note: Where two or more Photo Finish cameras are used, one should be designated as official by the Technical Delegate(s) (or International Photo Finish Judge where appointed) before the start of the competition. The times and places from the images of the other camera(s) should not be considered unless there is reason to doubt the accuracy of the official camera or if there is need to use the supplementary images to resolve uncertainties in the finishing order (i.e. athletes wholly or partially obscured on the image from the official camera).

21. In conjunction with an adequate number of assistants, the Chief Photo Finish Judge shall determine the placing of the athletes and,

as a consequence, their official times. He shall ensure that these results are correctly entered in or transferred to the competition results system and conveyed to the Competition Secretary.

At major events where the technology is available, the photo finish image is often immediately provided on the video board or published on the internet. It has become the practice to provide athletes, or persons on their behalf, who are considering making a protest or appeal the opportunity to see the photo, in order to avoid time being spent on any unnecessary protests or appeals.

22. Times from the Photo Finish System shall be regarded as official unless for any reason the appropriate official decides that they obviously must be inaccurate. If such is the case, the times of the back-up Timekeepers, if possible adjusted based on information on time intervals obtained from the Photo Finish image, shall be official. Such back-up Timekeepers must be appointed where any possibility exists of failure of the timing system.
23. Times shall be read and recorded from the Photo Finish image as follows:
 - (a) For all races up to and including 10,000m, unless the time is an exact 0.01 second, the time shall be converted and recorded to the next longer 0.01 second, e.g. 26:17.533 shall be recorded as 26:17.54.
 - (b) For all races on the track longer than 10,000m, all times not ending in two zeroes shall be converted and recorded to the next longer 0.1 second, e.g. 59:26.322 shall be recorded as 59:26.4.
 - (c) For all races held partly or entirely outside the stadium, all times not ending in three zeroes shall be converted and recorded to the next longer whole second, e.g. 2:09:44.322 shall be recorded as 2:09:45.

Transponder System

24. The use of Transponder Timing Systems complying with IAAF Rules in events held under Rules 230 (races not held completely in the stadium), 240, 250, 251 and 252 is permitted provided that:
 - (a) None of the equipment used at the start, along the course or at the finish line constitutes a significant obstacle or barrier to the progress of an athlete.

- (b) The weight of the transponder and its housing carried or worn by the athlete is not significant.
- (c) The System is started by the Starter's gun or synchronised with the start signal.
- (d) The System requires no action by an athlete during the competition, at the finish or at any stage in the result processing.
- (e) For all races, all times not ending in zero shall be converted and recorded to the next longer whole second, e.g. 2:09:44.3 shall be recorded as 2:09:45.

Note: The official time shall be the time elapsed between the firing of the starting gun (or the synchronised start signal) and the athlete reaching the finish line. However, the time elapsed between an athlete crossing the start line and the finish line can be made known to him, but will not be considered an official time.

- (f) Whilst the determination of the finishing order and times may be considered official, Rules 164.2 and 165.2 must be applied where required.

Note: It is recommended that Judges and/or video recording(s) also be provided to assist in determining the finishing order and the identification of athletes.

It is important that when using transponder timing that appropriate back-up systems are put in place by the Organisers, especially to respect Rule 165.24(f). The provision of back-up Timekeepers, and more importantly Finish Judges to adjudicate on close finishes (which might not be differentiated by chip timing) is strongly recommended.

25. The Chief Transponder Timing Judge shall be responsible for the functioning of the System. Before the start of the competition, he will meet the technical staff involved and familiarise himself with the equipment, checking all applicable settings. He shall supervise the testing of the equipment and ensure that the passing of the transponder over the finish line will record the athlete's finish time. In conjunction with the Referee, he shall ensure that provision is made for the application, when necessary, of Rule 165.24(f).

RULE 165 S 1 UKA SUPPLEMENT UK RECORDS

In the event of a National record claim the time should be taken by three graded Timekeepers, each of whom should be at least Level 4. If a fully automatic finish system is not in operation they must show their timings to the Chief Timekeeper and certify these times on the appropriate Record Application form.

RULE 166 SEEDINGS, DRAWS AND QUALIFICATION IN TRACK EVENTS

Rounds and Heats

1. Qualification Rounds shall be held in Track Events in which the number of athletes is too large to allow the competition to be conducted satisfactorily in a single round (final). Where Qualification Rounds are held, all athletes must compete in, and qualify through, all such rounds except that the relevant governing body may, for one or more events, authorise the conduct of additional preliminary qualification rounds(s) either at the same competition or at one or more earlier competition(s) to determine some or all of the athletes who shall be entitled to participate and in which round of the competition. Such procedure and any other means (such as achieving entry standards during a specified period, by specified placing in a designated competition or by specified rankings) by which an athlete is entitled to participate, and in which round of the competition, shall be set out in the regulations for each competition.

Note: See also Rule 146.4(c).

2. The Qualification Rounds for Track Events shall be arranged as follows by the appointed Technical Delegates. If no Technical Delegates have been appointed they shall be arranged by the Organisers.
 - (a) The regulations for each competition should include tables which shall, in the absence of extraordinary circumstances, be used to determine the number of rounds, the number of heats in each round and the qualification procedure, i.e. those to

advance by place (P) and time (T). Such information shall also be provided for any preliminary qualifications.

Tables which may be used in the absence of any provision in applicable regulations or other determination by the Organisers shall be published on the IAAF website.

- (b) Whenever possible, representatives of each Member or team and the best performed athletes shall be placed in different heats in all Qualification Rounds of the competition. In applying this Rule after the first round, the required exchanges of athletes between heats should, to the extent possible, be made between athletes seeded in the same “group of lanes” according to Rule 166.4(b).
- (c) When heats are being arranged, as much information as possible about the performances of all athletes should be considered and the heats drawn so that, normally, the best performed athletes reach the final.

The Qualification Rounds should determine in the best possible way the athletes who will take part in the next round and eventually the final. This includes avoiding where possible the clashing of the best performed athletes (determined generally on performance in the qualification period but also taking into account such matters as outstanding recent career records) in the same heats as also applies to athletes from the same Member or team.

For major competitions, at least, the basis of the seeding should be the best times achieved by each athlete in valid conditions (including with wind readings for the relevant events) during the pre-determined period. This period will usually be specified in the Technical Regulations or in the document setting out the entry conditions and standards for the competition. Where there is no such specification, then the Technical Delegate(s) or the Organisers should decide the basis on which the seeding will be determined.

Such factors as performances achieved during training or tests, even if they appeared to look like competition or notions about what an athlete might "be worth" but has never achieved, should not be taken into account in seeding.

The requirements of the Rule in relation to the "best performed athletes"

does require some deviation from the strict protocol outlined above. For example, an athlete who might normally be seeded in a high position might not have any, or only a poor, valid performance in the predetermined period (through injury, illness, ineligibility or in the case of indoor meetings only have outdoor results). Whilst he would normally be placed lower or at the bottom of the seeding list, adjustment should be considered by the Technical Delegate(s). Similar principles should be applied to avoid a clash in a Qualification Round between athletes considered to be the favourites to place highly in the event if the results of the previous round would strictly dictate that they should be in the same heat. At this same time any adjustments to ensure as much as possible that athletes from the same nation or team are in different heats should also be made.

In all such cases adjustments of the seeding should be made after the initial allocation to the heats but before any draw is made for the lanes.

In applying these principles exchanges of athletes should be made:

- (a) in the first round, between athletes with a similar ranking on the list of best valid performances during the pre-determined period; and
- (b) in subsequent rounds, between athletes seeded in the same “group of lanes” according to Rule 166.4(b).

Following these principles is more important in competitions in which the number of rounds has been reduced in some events - making accurate and well considered seeding vital to achieving both a fair and an athletically appealing outcome.

For lower level competitions, the Technical Delegate(s) or the Organisers may consider use different principles to achieve a similar final outcome.

Ranking and Composition of Heats

- 3. (a) For the first round, the athletes shall be placed in heats using the zigzag distribution with the seeding determined from the relevant list of valid performances achieved during the predetermined period.
- (b) After the first round, the athletes shall be placed in the heats of subsequent rounds in accordance with the following procedures:
 - (i) for events of 100m to 400m inclusive, and relays up to and including 4 × 400m, seeding shall be based upon placings and times of each previous round. For this purpose, athletes

shall be ranked as follows:

Fastest heat winner
2nd fastest heat winner
3rd fastest heat winner, etc.

Fastest 2nd place
2nd fastest 2nd place
3rd fastest 2nd place, etc.

(Concluding with)
Fastest time qualifier
2nd fastest time qualifier
3rd fastest time qualifier, etc.

- (ii) for other events, the original performance lists shall continue to be used for seeding, modified only by improvements in performances achieved during the earlier round(s).
- (c) The athletes shall then be placed in heats in the order of seeding in a zigzag distribution, e.g. three heats will consist of the following seedings:

A	1	6	7	12	13	18	19	24
B	2	5	8	11	14	17	20	23
C	3	4	9	10	15	16	21	22

- (d) In each case, the order in which heats are to be run shall be determined by draw after the composition of the heats has been decided.

For the first round in order to reduce the number of heats required, it is acceptable and normal for additional available lanes (for example a ninth lane on a straight or oval track) to be used in races up to and including 400m and to have more than one athlete in a lane at the start of an 800m race.

The random draw to determine the order in which the heats are conducted is based on fairness. In middle and long distance races the athletes running in the last heat will know as far as qualifying by times the performance they have to realise in order to qualify. Even with the shorter

aces there is a fairness aspect as weather conditions can change (rain suddenly falling or an alteration in wind strength or direction). Fairness dictates that order be determined by chance.

Draw for Lanes

4. For events 100m to 800m inclusive, and relays up to and including 4 × 400m, where there are several successive rounds of a race, lanes will be drawn as follows:
 - (a) In the first round and any additional preliminary qualification round as per Rule 166.1, the lane order shall be drawn by lot.
 - (b) For the following rounds, athletes shall be ranked after each round in accordance with the procedure shown in Rule 166.3(b)(i) or, in the case of 800m, 166.3(b)(ii).

Three draws will then be made:

 - (i) one for the four highest ranked athletes or teams to determine placings in lanes 3, 4, 5 and 6;
 - (ii) another for the fifth and sixth ranked athletes or teams to determine placings in lanes 7 and 8, and
 - (iii) another for the two lowest ranked athletes or teams to determine placings in lanes 1 and 2.

Note (i): When there are fewer or more than 8 lanes, the above system with the necessary modifications should be followed.

Note (ii): In competitions under Rules 1.1(d) to (j), the 800m event may be run with one or two athletes in each lane, or with group start behind an arced line. In competitions under Rules 1.1(a), (b), (c) and (f), this should normally be applied only in the first round, unless because of ties or advancement by the Referee or the Jury of Appeal, there are more athletes in a race of a subsequent round than were anticipated.

Note (iii): In any 800 metres race, including a final, where for any reason there are more athletes competing than lanes available, the Technical Delegate(s) shall determine in which lanes more than one athlete will be drawn.

Note (iv): When there are more lanes than athletes, the inside lane(s) should always remain free.

With regard to Note (iii), there is no exact specification as to how the

Technical Delegates should act as the situations which may give rise to it may vary greatly. However this issue only affects the running of the first bend of the race and is not as important as the allocation of lanes in a shorter race. Technical Delegate(s) are advised to place the additional athlete(s) in the lane(s) where the "double-up" will cause least inconvenience - usually the outer lanes so that the athletes are not running around a tighter bend together.

As to Note (iv), where a stadium has more than eight lanes available, the Technical Delegate(s) (or if none the Organisers) should decide in advance which lanes are to be used for this purpose. For example, in the case of a nine-lane oval track, lane one would not be used in cases where less than nine athletes are taking part in a race. Consequently, for the purposes of Rule 166.4, lane 2 is regarded as lane 1 and so on.

5. In competitions under Rules 1.1(a), (b), (c) and (f), for events longer than 800m, relays longer than $4 \times 400\text{m}$ and any event where only a single round (final) is required, lanes / starting positions shall be drawn by lot.
6. Where it is decided to conduct a series of races in an event rather than rounds and finals, the regulations for the competition shall set out all relevant considerations including seedings and draws and the method by which the final results will be determined.
7. An athlete shall not be allowed to compete in a heat or lane other than the one in which his name appears, except in circumstances which, in the opinion of the Technical Delegate(s) or the Referee, justify an alteration.

Progression

8. In all Qualification Rounds, the tables should, where practicable, allow at least the first and second places in each heat to qualify for the next round and it is recommended that, where possible, at least three in each heat should qualify.

Except where Rule 167 applies, any other athletes may qualify by place or by time according to Rule 166.2, the applicable Technical Regulations, or as determined by the Technical Delegate(s). When athletes are qualified according to their times, only one system of timing may be applied.

Where tables are prescribed in the regulations for a competition it is usual that the principle set out in Rule 166.8 will have been incorporated. Where not, the Technical Delegates or Organisers should follow same principle when establishing the progression table to be used.

There will however be occasions when Rule 167 may cause a variation to be applied, particularly where there is a tie for the last qualifying position based on place. In such cases, it may be necessary for one less athlete to progress on time. In circumstances where there are sufficient additional lanes available, or in the case of the 800m (where a lane at the start may be used for more than one athlete) or a non-laned race, the Technical Delegate(s) may decide to progress an additional athlete(s).

Because of the provision within Rule 166.8 that for time qualification only one system of timing may be applied it is important for back-up timing systems to be available for qualification rounds in case the primary system (usually photo finish) fails. In the event that only times from different timing systems are available for two or more heats, the Technical Delegates in conjunction with the Track Referee should determine, within the circumstances of the particular competition, the fairest method for determining those athletes who should proceed to the next round. Where additional lanes are available, it is recommended that this option be considered first.

One Day Meetings

9. In competitions held under Rule 1.1(e), (i) and (j) athletes may be seeded, ranked and/or allocated to lanes in accordance with the applicable regulations for the competition or any other method determined by the Organisers but preferably notified to the athletes and their representatives in advance.

In one day meetings, if there is only a "final" round but with more than one race, the races should be arranged according to any applicable regulations for the meeting or the series of meetings of which it is a part. If there are none then it is usual for allocation of athletes to the various "races" to be undertaken by the Organisers or if requested by the appointed Technical Delegate(s).

Similar considerations apply to how the final ranking of the athletes in such events will be made. In some meetings the "race(s)" other than the main race are regarded as separate races and are not considered for the overall ranking but in others the results of more than one race are

"combined" to give the overall ranking. It is highly advisable to ensure that whichever is to apply for the competition is also notified to the participants in advance as it may affect prizes and other considerations.

Minimum Times between Rounds

10. The following minimum times must be allowed, when practicable, between the last heat of any round and the first heat of a subsequent round or final:

Up to and including 200m	45 minutes
Over 200m up to and including 1000m	90 minutes
Over 1000m	Not on the same day

RULE 166 S 1 UKA SUPPLEMENT SEEDINGS, DRAWS AND QUALIFICATIONS

Qualification from preliminary heats

The following minimum times must be allowed between the last heat of the round and the first heat of the subsequent round or final.

Up to 100 metres	20 minutes
Over 100m and up to 200m	40 minutes
Over 200m and up to 400m	60 minutes
Over 400m and up to 800m	80 minutes
Over 800m	100 minutes

RULE 167 TIES

1. If the Judges or the Photo Finish Judges are unable to separate the athletes for any place according to Rules 164.2, 165.18, 165.21 or 165.24 (as may be applicable), it shall be determined to be a tie and the tie shall remain.

Tie for ranking position (according to Rule 166.3(b))

2. If there is a tie for any ranking position under Rule 166.3 (b), the Chief Photo Finish Judge shall consider the actual times recorded by the athletes to .001 second and if it is equal, it shall be determined to be a tie and lots shall be drawn to determine the higher ranking position.

Tie for last qualifying position based on place

3. If after the application of Rule 167.1, there is a tie for a last qualifying position based on place, if there are lanes or positions available (including lane sharing in 800m races) the tying athletes shall be placed in the next round. If that is not practicable lots shall be drawn to determine which athlete(s) shall be placed in the next round.
4. Where qualifying for the next round is based on place and time (e.g., the first three in each of two heats plus the next two fastest), and there is a tie for the last qualifying position based on place, placing the tied athletes in the next round shall reduce the number of athletes qualifying based on time.

Tie for last qualifying position based on time

5. If there is a tie for a last qualifying position based on time, the Chief Photo Finish Judge shall consider the actual times recorded by the athletes to .001 second and if it is equal, it shall be determined to be a tie. If there are lanes or positions available (including lane sharing in 800m races) the tying athletes shall be placed in the next round. If that is not practicable lots shall be drawn to determine which athlete(s) shall be placed in the next round.

RULE 168 HURDLE RACES

1. The standard distances shall be:
Men, U20 Men and U18 Boys: 110m, 400m
Women, U20 Women and U18 Girls: 100m, 400m
There shall be ten flights of hurdles in each lane, set out in accordance with the following table:

Men, U20 Men and U18 Boys

Distance of race	Distance from start line to first hurdle	Distance between hurdles	Distance from last hurdle to finish line
110m	13.72m	9.14m	14.02m
400m	45.00m	35.00m	40.00m

Women, U20 Women and U18 Girls

Distance of race	Distance from start line to first hurdle	Distance between hurdles	Distance from last hurdle to finish line
100m	13.00m	8.50m	10.50m
400m	45.00m	35.00m	40.00m

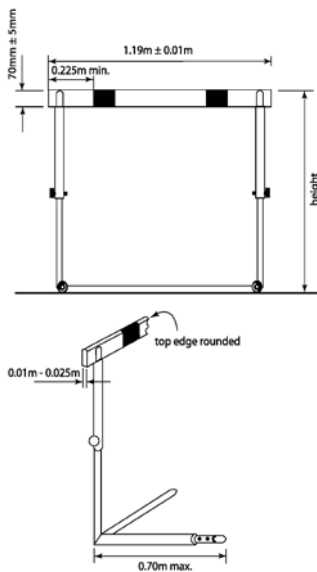

Figure 168 – Example of a hurdle

Each hurdle shall be so placed on the track that the feet shall be on the side of the approach by the athlete. The hurdle shall be so placed that the vertical plane of the side of the bar nearer to the approaching hurdler coincides with the track marking nearest the athlete.

2. The hurdles shall be made of metal or some other suitable material with the top bar of wood or other non-metallic suitable material. They shall consist of two feet and two uprights supporting a

rectangular frame, reinforced by one or more cross bars, the uprights to be fixed at the extreme end of each base. The hurdle shall be of such a design that a force at least equal to the weight of 3.6kg applied horizontally to the centre of the top edge of the top bar is required to tilt it. The hurdle may be adjustable in height for each event. The counterweights shall be adjustable so that at each height a force at least equal to the weight of 3.6kg and not more than 4kg is required to tilt it.

The maximum horizontal deflection of the top bar of a hurdle (including any deflection of the uprights) when subject to a centrally applied force equal to the weight of 10kg shall not exceed 35mm.

3. Dimensions: The standard heights of the hurdles shall be:

Distance	Men U20	Men U18	Boys U18	Women/U20	U18Girls
110m/100m	1.067m	0.991m	0.914m	0.838m	0.762m
400m	0.914m	0.914m	0.838m	0.762m	0.762m

Note: Due to manufacturing varieties, hurdles up to 1.000m are also acceptable in the U20 110m Hurdles.

In each case, there shall be a tolerance allowance of 3mm, above and below the standard heights, to allow for variation in the manufacture. The width of the hurdles shall be from 1.18m to 1.20m. The maximum length of the base shall be 0.70m. The total weight of the hurdles shall be not less than 10kg.

4. The height of the top bar shall be $70\text{mm} \pm 5\text{mm}$. The thickness of this bar should be between 10mm and 25mm, and the top edges should be rounded. The bar should be firmly fixed at the extremities.
5. The top bar should be painted with white and black stripes, or with other strong distinctive contrasting colours (and also in contrast with the surrounding environment), such that the lighter stripes, which should be at least 0.225m wide are on the outside. It shall be coloured so as to be visible to all sighted athletes.
6. All races shall be run in lanes and each athlete shall keep to, and go over the hurdles in, his own lane throughout, except as provided in Rule 163.4. Unless there is no effect or obstruction upon any other athlete(s) in the race, and Rule 168.7(a) is not infringed an athlete shall also be disqualified if he directly or indirectly knocks down or significantly displaces a hurdle in another lane.

The requirement to go over each hurdle should not be read as requiring the athlete to go over each hurdle in his own lane - provided always the intention of Rules 163.3 and 163.4 is followed. But if an athlete knocks down or displaces a hurdle in another lane and thereby affects the progress of another athlete he should be disqualified.

Situations when an athlete knocks down or displaces a hurdle in another lane should be interpreted in a logical way. For example, an athlete who knocks down or displaces a hurdle in the lane of an athlete who has already gone over that hurdle, should not necessarily be disqualified unless they otherwise infringe the Rules, e.g. by moving to an inside lane on the bend. The intent of this Rule is to make it clear that an athlete who in making such action affects another athlete should be considered for disqualification.

Referees and Umpires must nonetheless be alert and be sure that each athlete has kept to his own lane. Additionally it is common in hurdle races that athletes stretch their arms widely while going over the hurdle, thus hitting or hampering the athlete in the next lane. This can best be noticed by Umpires standing or a video camera being placed head-on to the athletes. In this regard Rule 163.2 may be applied.

7. Each athlete shall go over each hurdle. Failure to do so will result in a disqualification.

In addition, an athlete shall be disqualified, if:

- (a) his foot or leg is, at the instant of clearance, beside the hurdle (on either side), below the horizontal plane of the top of any hurdle; or
- (b) in the opinion of the Referee, he deliberately knocks down any hurdle.

Note: Provided that this Rule is otherwise observed and the hurdle is not displaced or its height lowered in any manner including tilting in any direction, an athlete may go over the hurdle in any manner.

Rule 168.7(a) applies to both the athlete's "lead" and "trail" legs. "Knocking down" a hurdle does not in itself result in disqualification. Many athletes knock down the hurdle by hitting the top of the bar when pulling through their back leg. Deliberately knocking down a hurdle (e.g.

when the athlete arrives too near the hurdle) is an infringement. The Referee should be satisfied that the action of the athlete was to deliberately knock down the hurdle so as to avoid the key requirement of Rule 168.7 that each athlete shall go over each hurdle. The most obvious example is where the athlete uses his hand. In other cases, such as where it appears the foot or the underside of the thigh may have been used deliberately, the Referee must have a high level of certainty that the action was deliberate and in contravention of the intention of the Rule. An example of where the athlete does not raise his lead leg sufficiently high as to clear the hurdle and as a result knocks it down, could be such a case.

In relation to the Note, it will mainly be relevant to competitions at a lower level but is nonetheless applicable to all. Essentially it permits an athlete, often one who has fallen or lost their stride pattern, to for example place their hands on the hurdle and “climb over”.

8. Except as provided in Rules 168.6 and 168.7, the knocking down of hurdles shall not result in disqualification nor prevent a Record being made.

RULE 168 S 1 UKA SUPPLEMENT HURDLES SPECIFICATIONS

Distance of race	Height of hurdle	Distance to 1st flight	Distance between flights	Distance to finish	No of hurdles	Track Marking Colour
------------------	------------------	------------------------	--------------------------	--------------------	---------------	----------------------

MEN'S EVENTS

Under 17 (100m 2.7kg Toppling Weight; 400m: 3.6kg Toppling Weight)

100m	.914m	13.0m	8.5m	10.5m	10	Yellow
400m	.840m	45.0m	35.0m	40.0m	10	Green

Under 15 (2.7kg Toppling Weight)

80m	.840m	12.0m	8.0m	12.0m	8	Black
-----	-------	-------	------	-------	---	-------

Under 13 (2.7kg Toppling Weight)

75m	.762m	11.5m	7.5m	11.0m	8	Orange
-----	-------	-------	------	-------	---	--------

Distance of race	Height of hurdle	Distance to 1st flight	Distance between flights	Distance to finish	No of hurdles	Track Marking Colour
------------------	------------------	------------------------	--------------------------	--------------------	---------------	----------------------

WOMEN'S EVENTS

Under 17 (2.7kg Toppling Weight)

80m	.762m	12.0m	8.0m	12.0m	8	Black
300m	.762m	50.0m	35.0m	40.0m	7	Green

Under 15 (2.7kg Toppling Weight)

75m	.762m	11.5m	7.5m	11.0m	8	Orange
-----	-------	-------	------	-------	---	--------

Under 13 (2.7kg Toppling Weight)

70m	.685m	11.0m	7.0m	10.0m	8	Pink
-----	-------	-------	------	-------	---	------

Distance of race	Height of hurdle	Distance to 1st flight	Distance between flights	Distance to finish	No of hurdles	Track Marking Colour
------------------	------------------	------------------------	--------------------------	--------------------	---------------	----------------------

MASTER'S EVENTS

Men 35 - 49 (3.6kg Toppling Weight)

110m	.991m	13.72m	9.14m	14.02m	10	Blue
400m	.914m	45.0m	35.0m	40.0m	10	Green

Men 50 - 59 (100m: 3.6kg Toppling Weight; 400m: 2.7kg Toppling Weight)

100m	.914m	13.0m	8.5m	10.5m	10	Yellow
400m	.840m	45.0m	35.0m	40.0m	10	Green

Men 60 – 69 (2.7kg Toppling Weight)

80m	.762m	12.0m	7.0m	19.0m	8	-
300m	.685m	50.0m	35.0m	40.0m	7	Green

Men 70 – 79 2.7kg Toppling Weight)

80m	.685m	12.0m	7.0m	19.0m	8	-
200m	.685m	20.0m	35.0m	40.0m	5	-

Distance of race	Height of hurdle	Distance to 1st flight	Distance between flights	Distance to finish	No of hurdles	Track Marking Colour
------------------	------------------	------------------------	--------------------------	--------------------	---------------	----------------------

Women 35 – 39 (2.7kg Toppling Weight)

100m	.840m	13.0m	8.5m	10.5m	10	Yellow
400m	.762m	45.0m	35.0m	40.0m	10	Green

Women 40 – 49 (2.7kg Toppling Weight)

80m	.762m	12.0m	8.0m	12.0m	8	Black
400m	.762m	45.0m	35.0m	40.0m	10	Green

Women 50 – 59 (2.7kg Toppling Weight)

80m	.762m	12.0m	7.0m	19.0m	8	-
300m	.762m	50.0m	35.0m	40.0m	7	Green

Women 60 and over (2.7kg Toppling Weight)

80m	.685m	12.0m	7.0m	19.0m	8	-
-----	-------	-------	------	-------	---	---

Women 60 – 69 (2.7kg Toppling Weight)

300m	.685m	50.0m	35.0m	40.0m	7	Green
------	-------	-------	-------	-------	---	-------

Women 70 and over (2.7kg Toppling Weight)

200m	.685m	20.0m	35.0m	40.0m	5	-
------	-------	-------	-------	-------	---	---

MASTERS' EVENTS

Men 35 - 49 (3.6kg Toppling Weight)

60m	.991m	13.72m	9.14m	9.72m	5
-----	-------	--------	-------	-------	---

Men 50 - 59 (3.6kg Toppling Weight)

60m	.914m	13.0m	8.5m	13.0m	5
-----	-------	-------	------	-------	---

Men 60 – 69 (2.7kg Toppling Weight)

60m	.840m	12.0m	8.0m	16.0m	5
-----	-------	-------	------	-------	---

Men 70 – 79 2.7kg Toppling Weight)

60m	.762m	12.0m	7.0m	20.0m	5
-----	-------	-------	------	-------	---

Men 80 and over 2.7kg Toppling Weight)

60m	.685m	12.0m	7.0m	20.0m	5
-----	-------	-------	------	-------	---

Women 35 – 39 (2.7kg Toppling Weight)

60m	.840m	13.0m	8.5m	13.0m	5
-----	-------	-------	------	-------	---

Women 40 – 49 (2.7kg Toppling Weight)

60m	.762m	12.0m	8.0m	16.0m	5
-----	-------	-------	------	-------	---

Women 50 – 59 (2.7kg Toppling Weight)

60m	.762m	12.0m	7.0m	20.0m	5
-----	-------	-------	------	-------	---

Women 60 and over (2.7kg Toppling Weight)

60m	.685m	12.0m	7.0m	20.0m	5
-----	-------	-------	------	-------	---

NOTE 1: In each case there shall be a tolerance of .003m above and below the standard height to allow for variation in manufacture. NOTE 2: Due to manufacturing varieties, hurdles up to 1.000m are also acceptable in the U20 110m Hurdles.

NOTE 3: Under 17 Men seeking qualification standards for IAAF U18 Competition are advised to request the appropriate toppling weight to be applied.

RULE 169 STEEPLECHASE RACES

1. The standard distances shall be: 2000m and 3000m.
2. There shall be 28 hurdle jumps and 7 water jumps included in the 3000m event, and 18 hurdle jumps and 5 water jumps in the 2000m event.
3. For the steeplechase events, there shall be five jumps in each lap after the finish line has been passed for the first time, with the water

jump as the fourth. The jumps should be evenly distributed, so that the distance between the jumps shall be approximately one fifth of the nominal length of the lap.

Note (i): Adjustment to the hurdle spacing may be necessary to ensure that safe distances from a hurdle / start line and to the next hurdle are maintained before and after the finish line respectively, as indicated in the IAAF Track and Field Facilities Manual.

Note (ii): In the 2000m event, if the water jump is on the inside of the track, the finish line has to be passed twice before the first lap with five jumps.

4. In the 3000m event, the distance from the start to the beginning of the first lap shall not include any jumps, the hurdles being removed until the athletes have entered the first lap. In the 2000m event, the first jump is at the third hurdle of a normal lap. The previous hurdles shall be removed until the athletes have passed them for the first time.
5. The hurdles shall be $0.914\text{m} \pm 0.003\text{m}$ high for men's / boys' events and $0.762\text{m} \pm 0.003\text{m}$ for women's / girls' events and shall be at least 3.94m wide. The section of the top bar of the hurdles, and the hurdle at the water jump, shall be 0.127m square. The weight of each hurdle shall be between 80kg and 100kg . Each hurdle shall have on either side a base between 1.2m and 1.4m (see Figure 169a).

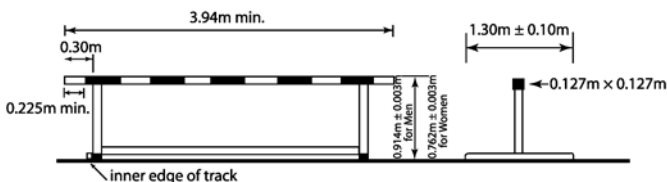

Figure 169a - Example of a steeplechase hurdle

The hurdle at the water jump shall be $3.66\text{m} \pm 0.02\text{m}$ wide, and shall be firmly fixed in or to the the pit concrete walls, so that minimal only horizontal movement is possible.

The top bars should be painted with white and black stripes, or with

other strong distinctive contrasting colours (and also in contrast with the surrounding environment), such that the lighter stripes, which should be at least 0.225m wide, are on the outside and shall be coloured so as to be visible to all sighted athletes.

The hurdle shall be placed on the track so that at least 0.30m of the top bar will extend inside the inner edge of the track.

Note: It is recommended that the first hurdle taken in the race should be at least 5m in width.

6. The water jump, including the hurdle, shall be $3.66\text{m} \pm 0.02\text{m}$ in length and the water pit shall be $3.66\text{m} \pm 0.02\text{m}$ in width.

The bottom of the water pit shall consist of a synthetic surface, or matting, of sufficient thickness to ensure safe landing, and allow for the spikes to grip satisfactorily. The depth of the water closest to the hurdle shall be 0.70m for approximately 0.30m. From there, the bottom shall have a uniform slope upwards to the level of the track at the farther end of the water pit. At the start of a race, the surface of the water shall be level with the surface of the track within a margin of 20mm.

Note: The depth of the water in the pit from the track surface level may be reduced for approximately 1.2m from 0.70m maximum down to 0.50m minimum. The uniform slope of the bottom of the pit ($12.4^\circ \pm 1^\circ$) shall be maintained as shown in Figure 169b. It is recommended that all new water pits be constructed to the shallower depth.

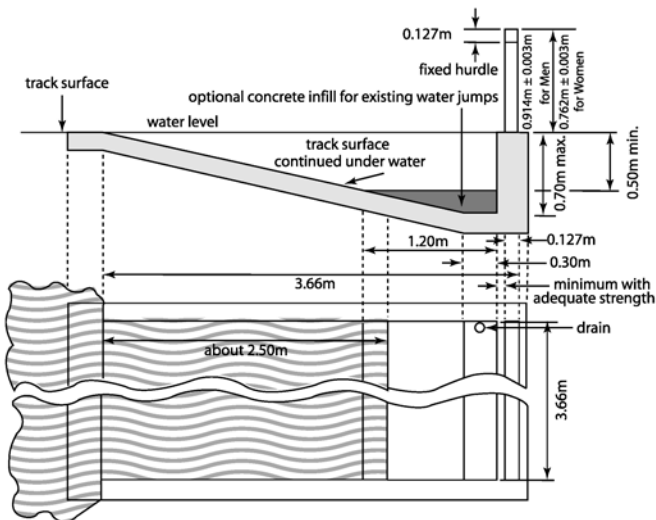

Figure 169b – Water jump

7. Each athlete shall go over or through the water and shall go over each hurdle. Failure to do so will result in a disqualification. In addition, an athlete shall be disqualified, if
- he steps to the one side or other of the water jump, or
 - his foot or leg is, at the instant of clearance, beside the hurdle (on either side), below the horizontal plane of the top of any hurdle.

Provided this Rule is observed, an athlete may go over each hurdle in any manner.

RULE 169 S 1 UKA SUPPLEMENT STEEPLECHASE RACES

- (1) Seniors, Under 20 and Under 17s are allowed to contest any steeplechase event. With effect from 1st April 2016 Under 15 athletes may compete in Steeplechase races over 1500m and a hurdle height of 0.762m on the understanding that this will be a developmental event until publication of the 2020 – 2022 Rule Book.
- (2) The standard events are:

Distance of of Race	Number of of Hurdles	Number of Water Jumps	Distance from start to first hurdle
3000m	28	7	257.8m
2000m	18	5	203.8m
1500m	13	3	255.8m

NOTE: Owing to the water jump having to be constructed on the arena inside or outside the track, thereby shortening or lengthening the normal distance of the lap, it is not possible to lay down any rule specifying the exact length of the lap or state precisely the position of the water jump.

It should be borne in mind that there must be enough distance from the starting line to the first hurdle to prevent competitors from overcrowding and there should be approximately 62.2m from the last hurdle to the finish line.

The water jump should be, where possible, the fourth jump in each lap. If necessary, the finish line should be moved to another part of the track.

- (3) The following measurements are given as a guide and any adjustments necessary should be made by lengthening or shortening the distance at the starting point of the race. It is assumed that a lap of 400 metres has been shortened by 6 metres by constructing the water jump inside the track.

(i) 3000 Metres

Distance from starting point to commencement of first lap, to be run without jumps	242.0m
Distance from commencement of 1st lap to 1st hurdle	15.8m
From 1st to 2nd hurdle	79.0m
From 2nd to 3rd hurdle	79.0m
From 3rd hurdle to water jump	79.0m
From water jump to 4th hurdle	79.0m
From 4th hurdle to finishing line	62.2m
7 laps of 394m =	2758.0m
plus	242.0m
	<u>3000m</u>

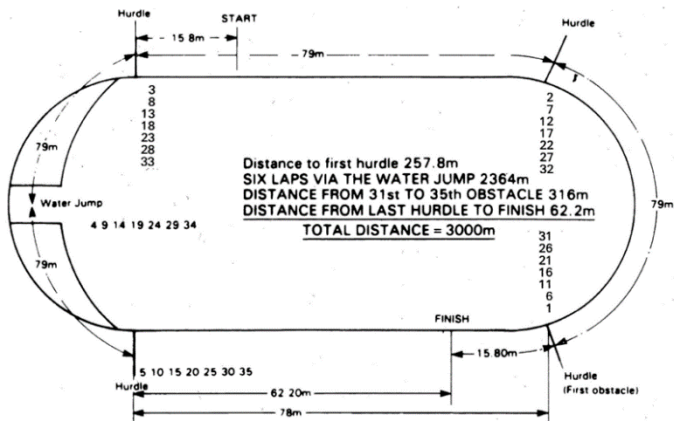

(ii) 2000 Metres

(if the course is laid out with a lap of 394m.)

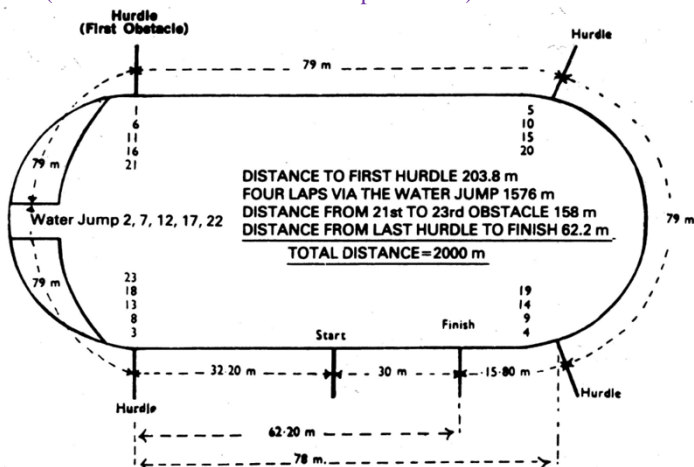

(iii) 1500 Metres

(if the course is laid out with a lap of 394m.)

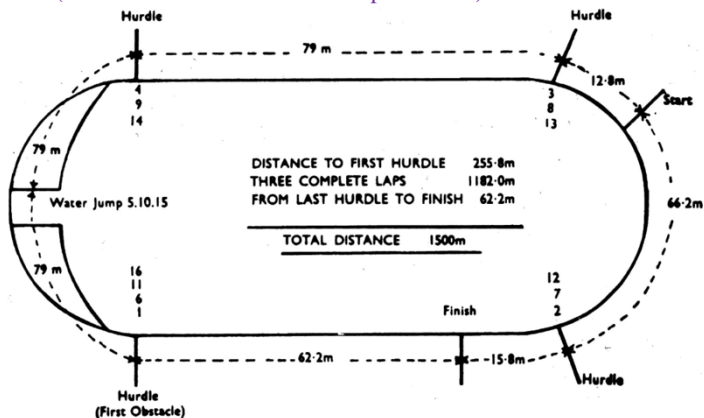

(4) Masters'

Men 35 – 59	3000m	.914m	28 barriers and 7 water jumps
Men 60+	2000m	.762m	18 barriers and 5 water jumps
Women 35+	2000m	.762m	18 barriers and 5 water jumps

RULE 170 RELAY RACES

1. The standard distances shall be: 4 × 100m, 4 × 200m, 100m-200m-300m-400m Medley Relay (Medley Relay), 4 × 400m, 4 × 800m, 1200m-400m-800m-1600m Distance Medley Relay (Distance Medley Relay), 4 × 1500m.

Note: The Medley Relay may be run with the legs in a different order in which case the appropriate adjustments should be made to the application of Rules 170.14, 170.18, 170.19 and 170.20.

2. Lines 50mm wide shall be drawn across the track to mark the distances of the legs and to denote the scratch line.
3. In the 4 x 100m and the 4 x 200m relays and for the first and second changes in the Medley Relay, each takeover zone shall be 30m long, of which the scratch line is 20m from the start of the zone. For the third change in the Medley Relay and in the 4 x 400m and longer relays each takeover zone shall be 20m long of which the scratch line is the centre.

The zones shall start and finish at the edges of the zone lines nearest the start line in the running direction. For each takeover conducted in lanes, a designated official shall ensure that the athletes are correctly placed in their takeover zone. The designated official shall also ensure that Rule 170.4 is observed.

UKA Note: In all cases where a track has not been remarked to take account of this Rule change then the existing mark for the start of the acceleration zone shall be used as the start of the 4 x 100m takeover zone.

The Umpires must ensure that each athlete from each team takes his position in the correct lanes or position. The Starter's Assistants will be responsible for the positioning of the first runners and for ensuring that each is supplied with a baton. They may also be assigned to assist at any takeover zones which subsequently occur at the start line. Chief Umpires

for each takeover zone and the umpires placed at their disposal will be responsible for the positioning of the subsequent runners. When all athletes are correctly positioned the zone Chief Umpire should advise the relevant other officials by the agreed means of communication – which for major competitions would usually be by radio.

They must also ensure that for all takeovers the outgoing runners' feet are completely inside the zone before they commence their movement which eventuates in the taking of the baton. This movement may not commence at any point outside the zone.

4. When all or the first portion of a Relay Race is being run in lanes, an athlete may place one check-mark on the track within his own lane, by using adhesive tape, maximum $0.05\text{m} \times 0.40\text{m}$, of a distinctive colour which cannot be confused with other permanent markings. No other check-mark may be used. The Judges shall direct the relevant athlete(s) to adapt or remove any marks not complying with this Rule. If they do not, the Judges shall remove them.

Note: Serious cases may further be dealt with under Rules 125.5 and 145.2.

5. The relay baton shall be a smooth hollow tube, circular in section, made of wood, metal or any other rigid material in one piece, the length of which shall be 0.28m to 0.30m. The outside diameter shall be $40\text{mm} \pm 2\text{mm}$ and it shall not weigh less than 50g. It should be coloured so as to be easily visible during the race.

6. (a) A baton shall be used for all Relay Races held in the Stadium and shall be carried by hand throughout the race. At least for competitions conducted under Rules 1.1 (a), (b), (c) and (f), each baton shall be numbered and of a different colour and may include a timing transponder.

Note: If possible, the allocation of the colour to each lane or starting order position should be shown on the start list.

- (b) Athletes are not permitted to wear gloves or to place material (other than those permitted by Rule 144.4(c)) or substances on their hands in order to obtain a better grip of the baton.
- (c) If dropped, the baton shall be recovered by the athlete who dropped it. He may leave his lane to retrieve it provided that, by doing so, he does not lessen the distance to be covered. In addition, where the baton is dropped in such a way that it moves sideways or forward in the direction of running (including

beyond the finish line), the athlete who dropped it, after retrieving it, must return at least to the point where it was last in his hand, before continuing in the race. Provided these procedures are adopted where applicable and no other athlete is impeded, dropping the baton shall not result in disqualification.

If an athlete does not follow this Rule, his team shall be disqualified.

7. The baton shall be passed within the takeover zone. The passing of the baton commences when it is first touched by the receiving athlete and is completed the moment it is in the hand of only the receiving athlete. In relation to the takeover zone, it is only the position of the baton which is decisive. Passing of the baton outside the takeover zone shall result in disqualification.

In determining the position of the baton, it is the whole baton which must be considered.

Umpires must be diligent to ensure that they observe any contact by the outgoing runner with the baton prior to the baton entering the takeover zone, particularly in 4x400m relays and longer. If the outgoing runner even touches the baton prior to the baton being inside the zone, the team will be subject to disqualification. They must also ensure that the baton is only in the hand of the receiving athlete before it “leaves” the takeover zone.

8. Until the moment when the baton is in the hand of only the receiving athlete, Rule 163.3 shall be applicable only to the incoming athlete. Thereafter it shall be applicable only to the receiving athlete. Additionally, athletes before receiving and/or after handing over the baton, should keep in their lanes or maintain position until the course is clear to avoid obstruction to other athletes. Rules 163.3 and 163.4 shall not apply to these athletes. If, however, an athlete impedes a member of another team, including by running out of position or lane, Rule 163.2 shall be applied.
9. If during the race an athlete takes or picks up the baton of another team, his team shall be disqualified. The other team should not be penalised unless an advantage is obtained.
10. Each member of a relay team may run one leg only. Any four athletes from among those entered for the competition, whether for that or any other event, may be used in the composition of the relay team for any round. However, once a relay team has started in a

competition, only two additional athletes may be used as substitutes in the composition of the team. If a team does not follow this Rule, it shall be disqualified.

11. The composition of a team and the order of running for a relay shall be officially declared no later than one hour before the published first call time (the time by which the athletes must be present in the Call Room) for the first heat of each round of the competition. Further alterations must be verified by a medical officer appointed by the Organisers and may be made only until the final call time (the time at which the athletes are listed to depart the Call Room) for the particular heat in which the team is competing. The team shall compete as named and in the declared order. If a team does not follow this Rule, it shall be disqualified.
12. The $4 \times 100\text{m}$ race shall be run entirely in lanes.
13. The $4 \times 200\text{m}$ race may be run in any of the following ways:
 - (a) where possible, entirely in lanes (four bends in lanes),
 - (b) in lanes for the first two legs, as well as that part of the third leg up to the nearer edge of the breakline described in Rule 163.5, where athletes may leave their respective lanes (three bends in lanes),
 - (c) in lanes for the first leg up to the nearer edge of the breakline described in Rule 163.5, where athletes may leave their respective lanes (one bend in lanes).

Note: Where not more than four teams are competing and option (a) is not possible, it is recommended that option (c) should be used.

14. The Medley Relay race should be run in lanes for the first two legs, as well as that part of the third leg up to the nearer edge of the breakline described in Rule 163.5, where athletes may leave their respective lanes (two bends in lanes).
15. The $4 \times 400\text{m}$ race may be run in either of the following ways:
 - (a) in lanes for the first leg, as well as that part of the second leg up to the nearer edge of the breakline described in Rule 163.5, where athletes may leave their respective lanes (three bends in lanes),
 - (b) in lanes for the first leg up to the nearer edge of the breakline described in Rule 163.5, where athletes may leave their

respective lanes (one bend in lanes).

Note: Where not more than four teams are competing, it is recommended that option (b) should be used.

16. The 4 × 800m race may be run in either of the following ways:
 - (a) in lanes for the first leg up to the nearer edge of the breakline described in Rule 163.5, where athletes may leave their respective lanes (one bend in lanes),
 - (b) without the use of lanes.
17. If an athlete does not follow Rule 170.13, 170.14, 170.15 or 170.16(a) his team shall be disqualified.
18. The Distance Medley Relay race and the 4 × 1500m race shall be run without the use of lanes.
19. For all takeovers, athletes are not permitted to begin running outside their takeover zones, and shall start within the zone. If an athlete does not follow this Rule, his team shall be disqualified.
20. In the Medley Relay, the athletes running the final leg and in the 4 × 400m race, the athletes running the third and fourth legs (or under Rule 170.15(b), the second leg) shall, under the direction of a designated official, place themselves in their waiting position in the same order (inside to out) as the order of their respective team members as they enter the last bend. Once the incoming athletes have passed this point, the waiting athletes shall maintain their order, and shall not exchange positions at the beginning of the takeover zone. If an athlete does not follow this Rule, his team shall be disqualified.

Note: In the 4 × 200m race (if this event is not run entirely in lanes) where the previous leg is not run in lanes, the athletes shall line up in the order of the start list (inside to out).

21. In any race, when lanes are not being used, including when applicable, in 4 × 200m, the Medley Relay and 4 × 400m, waiting athletes can take an inner position on the track as incoming team members approach, provided they do not jostle or obstruct another athlete so as to impede his progress. In 4 × 200m, the Medley Relay and 4 × 400m, waiting athletes shall maintain the order in accordance with Rule 170.20. If an athlete does not follow this Rule, his team shall be disqualified.

Chief Umpires must remain at the zone to which they and their Umpires have been assigned. Once the athletes are correctly placed in their lanes and the race has started, zone Chief Umpires and those Umpires assigned to them are responsible for reporting any infringements of both these Rules as well as any other infringements particularly those under Rule 163.

RULE 170 S 1 UKA SUPPLEMENT

RELAY RACES

- (1) On completion of the final leg the baton is to be handed to an official by the last runner. It is not to be dropped or thrown from the hand. Failure to comply with this instruction may lead to disqualification. (See also Rule 145)
- (2) The 4 x 300m Relay uses the 800m start line with the first leg being run in lanes until the break line described in Rule 163.5(a) (one bend in lanes).
The takeover zones for the 2nd, 3rd and 4th legs will be 20m metres, with no acceleration permitted (Rule 170.19).
Athletes for the 2nd, 3rd and 4th legs will be lined up by a designated official in the order (inside to out) of their respective team members as they enter the last bend (Rule 170.20).

SECTION IV – FIELD EVENTS

RULE 180 GENERAL CONDITIONS – FIELD EVENTS

Practice Trials at the Competition Area

1. At the competition area and before the beginning of the event, each athlete may have practice trials. In the case of throwing events, the practice trials will be in draw order and always under the supervision of the Judges.

Whilst in the past the Rules specified that there should be two practice trials for each athlete in throwing events, there is currently no such specification. Rule 180.1 should be interpreted as allowing whatever number of practice trials that may be included in the warm-up time available. Whilst for major events, two remains a standard practice, this is regarded as a minimum and should time be available and some or all of the athletes request additional practice trials, this can be permitted.

2. Once a competition has begun, athletes are not permitted to use, for practice purposes, as appropriate,
 - (a) the runway or take-off area;
 - (b) vaulting poles;
 - (c) implements;
 - (d) the circles or the ground within the sector with or without implements.

The application of this Rule should not prevent an athlete from touching, preparing or taping his vaulting pole or his selected implement in readiness for his trial provided that it does not endanger, delay or obstruct another athlete or other person. It is particularly important that the Judges interpret this Rule reasonably so as to ensure the competition proceeds in an efficient manner and the athlete is able if he so chooses to take his trial immediately his time begins.

Markers

3. (a) In all Field Events where a runway is used, markers shall be placed alongside it, except for High Jump where the markers can be placed on the runway. An athlete may use one or two markers (supplied or approved by the Organisers) to assist him

in his run-up and take-off. If such markers are not supplied, he may use adhesive tape but not chalk or similar substance nor anything which leaves indelible marks.

- (b) For throws made from a circle, an athlete may use one marker only. This marker may be placed only on the ground in the area immediately behind or adjacent to the circle. It must be temporary, in position only for the duration of each athlete's own trial, and shall not impair the view of the Judges. No personal markers may be placed in or beside the landing area.

Note: Each marker shall be composed of a single piece only.

- (c) For Pole Vault, the Organisers should place suitable and safe distance markers beside the runway at each 0.5m between the points 2.5m to 5m from the “zero” line and at each 1.0m from the 5m to the 18m point.
- (d) The Judges shall direct the relevant athlete to adapt or remove any marks not complying with this Rule. If he does not, the Judges shall remove them.

Note: Serious cases may further be dealt with under Rules 125.5 and 145.2

If the ground is wet, the adhesive tape can be fixed to the ground by drawing pins of several colours.

The requirement for each marker to be a single piece should be interpreted sensibly by the Referee. If for example the manufacturer has used two pieces connected to make a single structure which is intended to be used that way, it should be allowed. Similarly if an athlete chooses to place both his markers in the same place or in the case of the high jump an athlete who tears the tape he is given into one or more pieces to make a single marker of a different shape to stand out more clearly, these should also be acceptable.

Rule 180.3(c) is designed to assist athletes and their coaches in determining their take-off points and the progress on the runway. There is no set concept as to how they should be constructed or look – with Organisers and Referees having discretion in interpreting what is acceptable and fair within the intention of the Rule in each particular competition environment.

RULE 180 S 1 UKA SUPPLEMENT PRACTICE TRIALS

Practice Trials at the Competition Area

In the case of practice trials for throwing events the judges shall have the power to alter the order of the trials.

NOTE: In the Long and Triple Jumps athletes may request that a line be laid down alongside the runway, using tape which is a maximum of 5cm in width and 10cm in length. For the Long & Triple Jumps, this line is to be placed at 3m from the scratch line. If more than one take-off board is to be used for the Triple Jump, it shall only be placed for the board further (furthest) from the landing area.

Performance Markers and Wind Socks

4. (a) A distinctive flag or marker may be provided to mark the existing World Record and, when appropriate, the existing Area, National or Meeting Record.
- (b) One or more wind sock(s) should be placed in an appropriate position in all jumping events, Discus Throw and Javelin Throw, to show the athletes the approximate direction and strength of the wind.

Competing Order and Trials

5. Except where Rule 180.6 applies, the athletes shall compete in an order drawn by lot.
If any athlete by his own decision makes a trial in an order different from that previously determined, Rules 125.5 and 145.2 shall be applied. In the case of a warning, the result of the trial (valid or failure) will stand. If there is a Qualification Round, there shall be a fresh drawing of lot for the final.

RULE 180 S 2 UKA SUPPLEMENT ORDER OF COMPETING

The Judges shall have the power to alter the order of competing.

6. Except for the High Jump and Pole Vault, no athlete shall have more than one trial recorded in any one round of trials of the competition. In all Field Events, except for the High Jump and Pole Vault, where

there are more than eight athletes, each athlete shall be allowed three trials and the eight athletes with the best valid performances shall be allowed three additional trials, unless the applicable regulations provide otherwise.

In the case of the last qualifying place, if two or more athletes have the same best performances, Rule 180.22 shall be applied. If it is thus determined that there has been a tie, the tying athletes shall be allowed any additional trials, permitted by the applicable regulations.

Where there are eight athletes or fewer, each athlete shall be allowed six trials, unless the applicable regulations provide otherwise. If more than one fail to achieve a valid trial during the first three rounds of trials, such athletes shall compete in subsequent rounds of trials before those with valid trials, in the same relative order according to the original draw.

In both cases:

- (a) the competing order for any subsequent rounds of trials shall be in the reverse ranking order recorded after the first three rounds of trials, unless the applicable regulations provide otherwise;
- (b) when the competing order is to be changed and there is a tie for any position, those tying shall compete in the same relative order according to the original draw.

Note (i): For Vertical Jumps, see Rule 181.2

Note (ii): If one or more athlete(s) is permitted by the Referee to continue in a competition “under protest” in accordance with Rule 146.5, such athletes shall compete in all subsequent rounds of trials before all others continuing in the competition and if more than one, in the same relative order according to the original draw.

Note (iii): The regulations of the relevant governing body may specify the number of trials (provided it is no more than six) and the number of athletes which may progress to each additional round of trials after the third.

RULE 180 S 3 UKA SUPPLEMENT NUMBER OF TRIALS

The competition may be decided by each competitor being allowed from three to six trials with the number, order and method of qualification determined according to competition regulations governing that event.

Recording of Trials

7. Except in High Jump and Pole Vault, a valid trial shall be indicated by the measurement taken.
For the standard abbreviations and symbols to be used in all other cases see Rule 132.4.

Completion of Trials

8. The judge shall not raise a white flag to indicate a valid trial until a trial is completed. The judge may reconsider a decision if he believes he raised the incorrect flag.

The completion of a valid trial shall be determined as follows:

- (a) in the case of Vertical Jumps, once the judge has determined that there is no failure according to Rules 182.2, 183.2 or 183.4;
- (b) in the case of Horizontal Jumps, once the athlete leaves the landing area in accordance with Rule 185.2;
- (c) in the case of throwing events, once the athlete leaves the circle or runway in accordance with Rule 187.17.

Qualification Round

9. A Qualification Round shall be held in Field Events in which the number of athletes is too large to allow the competition to be conducted satisfactorily in a single round (final). When a Qualification Round is held, all athletes shall compete in, and qualify through, that round except that the relevant governing body may, for one or more events, authorise the conduct of additional preliminary qualification rounds(s) either at the same or at one or more earlier competition(s) to determine some or all of the athletes who shall be entitled to participate and in which round of the competition. Such procedure and any other means (such as achieving entry standards during a specified period, by specified placing in a designated competition or by rankings) by which an

athlete is entitled to participate, and in which round of the competition, shall be set out in the regulations for each competition. Performances accomplished in a Qualification Round or additional preliminary qualification rounds(s) shall not be considered as part of the final.

10. The athletes shall normally be divided into two or more groups at random, but whenever possible so that representatives of each Member or team shall be placed in different groups. Unless there are facilities for the groups to compete at the same time and under the same conditions, each group should start its practice trials immediately after the previous group has finished.
11. It is recommended that, in competitions of more than three days, a rest day be provided between Qualifying Rounds and the finals in the vertical jumping events.
12. The conditions for qualifying, the qualifying standard and the number of athletes in the final, shall be decided by the Technical Delegate(s). If no Technical Delegate(s) have been appointed, the conditions shall be decided by the Organisers. For competitions conducted under Rules 1.1(a), (b), (c) and (f), there should be at least 12 athletes in the final unless otherwise provided in the regulations for the competition.
13. In a Qualifying Round, apart from the High Jump and the Pole Vault, each athlete shall be allowed up to three trials. Once an athlete has achieved the qualifying standard, he shall not continue in the Qualifying Round.
14. In a Qualifying Round for the High Jump and the Pole Vault, the athletes, not eliminated after three consecutive failures, shall continue to compete according to Rule 181.2 (including passing a trial) until the end of the last trial at the height set as the qualifying standard, unless the number of athletes for the final has been reached as defined in Rule 180.12. Once it is determined that an athlete will be in the final, he shall not continue in the Qualifying Round.
15. If no athletes, or fewer than the required number of athletes, achieve the pre-set qualifying standard, the group of finalists shall be expanded to that number by adding athletes according to their performances in the Qualifying Round. In the case of the last qualifying place, if two or more athletes have the same best performances in the overall results of the competition, Rule 180.22

or 181.8 as appropriate shall be applied. If it is thus determined that there has been a tie, the tying athletes shall be placed in the final.

16. When a Qualifying Round for the High Jump and Pole Vault is held in two simultaneous groups, it is recommended that the bar be raised to each height at the same time in each group. It is also recommended that the two groups be of approximately equal strength.

It is important when seeding High Jump and Pole Vault qualifying groups that the requirements of Rule 180.10 and 180.16 are both observed. The Technical Delegates and the ITO/Referee must follow closely the progress of the qualifying rounds of the High Jump and the Pole Vault to ensure that on the one hand, the athletes must jump, as long as they are not eliminated under Rule 181.2 until the qualifying standard has been reached (unless the number of athletes for the final has been reached as defined in Rule 180.12) and on the other hand, any tie between athletes in the overall standings in the two Groups is resolved according to Rule 181.8. Close attention must also be kept to the application of Rule 180.14 to ensure that athletes do not unnecessarily continue in the competition once it is certain that they will be in the final regardless of what may happen to the other athletes continuing to compete in the Qualification Round.

Time Allowed for Trials

17. The official responsible shall indicate to an athlete that all is ready for the trial to begin, and the period allowed for this trial shall commence from that moment.

For the Pole Vault, the time shall begin when the crossbar has been adjusted according to the previous wishes of the athlete. No additional time will be allowed for further adjustment.

If the time allowed elapses after an athlete has started his trial, that trial should not be disallowed.

If after the time for a trial has begun, an athlete decides not to attempt that trial, it shall be considered a failure once that period allowed for the trial has elapsed.

The following times shall not be exceeded. If the time is exceeded, unless a determination is made under Rule 180.18, the trial shall be recorded as a failure:

Individual Events

	High Jump	Pole Vault	Other
More than 3 athletes (or for the very first trial of each athlete)	0.5 min	1 min	0.5 min
2 or 3 athletes	1.5 min	2 min	1 min
1 athlete	3 min	5 min	-
Consecutive trials	2 min	3 min	2 min

Combined Events

	High Jump	Pole Vault	Other
More than 3 athletes (or for the very first trial of each athlete)	0.5 min	1 min	0.5 min
2 or 3 athletes	1.5 min	2 min	1 min
1 athlete	2 min	3 min	-
Consecutive trials	2 min	3 min	2 min

Note (i): A clock which shows the remaining time allowed for a trial should be visible to an athlete. In addition, an official shall raise and keep raised, a yellow flag, or otherwise indicate, during the final 15 seconds of the time allowed.

Note (ii): In the High Jump and Pole Vault, any change in the time period allowed for a trial, except the time specified for consecutive trials, shall not be applied until the bar is raised to a new height. In the other Field Events, except for the time specified for consecutive trials, the time limit allowed will not change.

Note (iii): When calculating the number of athletes remaining in the competition, this shall include those athletes who could be involved in a jump off for first place.

Note (iv): When only one athlete (who has won the competition) remains in High jump or Pole Vault and is attempting a World Record or other record relevant to the competition, the time limit shall be increased by one minute beyond those set out above.

Whilst the Judges should always use a system which notifies or calls the next athlete who is to take his trial plus the one who is to follow, this is

essential when the time allowed for an athlete to take his trial is 30 seconds or 1 minute. They must also ensure that the competition area is completely ready for the next trial before calling the athlete and then starting the clock. The Judges and the Referee in particular must be fully aware of the current competition environment when deciding when to start the clock or to “time out” and call a failure.

Particular circumstances which should be taken into account are the availability of the runway for an athlete’s trial in High Jump and Javelin Throw (when Track Events are being held simultaneously in the same competition area) and the distance for athletes to walk to and through the cage to reach the circle to take their trial in Discus Throw and Hammer Throw.

To be clear, the time limit will not change in the final round of any horizontal Field Event, once only 2 or 3 athletes remain to take their trials. The 1 minute time limit only applies when a horizontal Field Event has only 2 or 3 athletes on the original start list (except for the very first trial of each athlete).

Substitute Trials

18. If, for any reason beyond his control, an athlete is hampered in a trial and is unable to take it, or the trial cannot be correctly recorded, the Referee shall have the authority to award him a substitute trial or to re-set the time either partially or in full.

No change in the order shall be permitted. A reasonable time shall be allowed for any substitute trial according to the particular circumstances of the case. In cases when the competition has progressed before the substitute trial is awarded, it should be taken before any other subsequent trials are then made.

There are several situations in which it may be appropriate for an athletes to be given a substitute trial including where because of procedural or technical failure a trial is not measured and it is not possible for a re-measurement to be accurately made. Whilst this should be avoided by good systems and backups, with technology being used more and more provision needs to be made for when things do go wrong. As no change in the competition order should be permitted (unless the problem is not immediately discovered and the competition has continued), the Referee must decide how long should be allowed for the substitute trial taking into account the specific circumstances of each particular case.

Absence during Competition

19. An athlete may not leave the immediate area of the event during the progress of the competition, unless he has the permission of, and is accompanied by, an official. If possible a warning should be given first, but for subsequent instances or in serious cases the athlete shall be disqualified.

UKA Note: Should there be insufficient Officials available, then an Official may grant an athlete permission to leave the area unaccompanied.

Change of Competition Area or Time

20. The Technical Delegate(s) or appropriate Referee shall have the authority to change the place or time of the competition if, in his opinion, the conditions justify it. Such a change should be made only after a round of trials has been completed.

Note: Neither the wind strength nor its change of direction is sufficient condition to change the place nor time of the competition.

The phrase "round of trials" instead of "rounds" is designed to ensure a clear difference between a "round of trials" within a Field Event competition and a "round of the competition" (i.e. a Qualification Round or a final).

If the conditions make it impossible to complete a round of trials before a change of place or time is made, the Technical Delegate (through the Referee) or Referee should normally void those trials already completed in that round of trials (always depending on and evaluating the conditions and the results of the trials up to the time of the interruption) and recommence the competition at the beginning of that round of trials. See also Rule 149.3.

Result

21. Each athlete shall be credited with the best of all his trials, including, in the case of High Jump and Pole Vault, those achieved in resolving a tie for first place.

Ties

22. Except for the High Jump and Pole Vault, the second best performance of the athletes having the same best performances shall determine whether there has been a tie. Then, if necessary, the third best, and so on. If the athletes are still equal following the application of this Rule 180.22, it shall be determined to be a tie.

Except in Vertical Jumps, in the case of a tie for any place, including first place, the tie shall remain.

Note: For Vertical Jumps, see Rules 181.8, 181.9.

A. VERTICAL JUMPS

RULE 181 GENERAL CONDITIONS – VERTICAL JUMPS

1. Before the competition begins, the Referee or the Chief Judge shall announce to the athletes the starting height and the subsequent heights to which the bar will be raised at the end of each round of trials, until there is only one athlete remaining having won the competition, or there is a tie for first place. (For Combined Events, see Rule 200.8(d)).

Trials

2. An athlete may commence jumping / vaulting at any height previously announced by the Referee or Chief Judge and may jump / vault at his own discretion at any subsequent height. Three consecutive failures, regardless of the height at which any of such failures occur, disqualify from further jumping / vaulting except in the case of a tie for first place.

The effect of this Rule is that an athlete may pass his second or third trial at a particular height (after failing first or second time) and still jump / vault at a subsequent height.

If an athlete passes a trial at a certain height, he may not make any subsequent trial at that height, except in the case of a jump-off for first place.

In the case of the High Jump and Pole Vault, if an athlete is not present when all other athletes who are present have completed the competition, the Referee shall deem that such athlete(s) has abandoned the competition, once the period for one further trial has elapsed.

3. Even after all the other athletes have failed, an athlete is entitled to continue jumping until he has forfeited his right to compete further.
4. Unless there is only one athlete remaining and he has won the competition:
 - (a) the bar shall never be raised by less than 2cm in the High Jump and 5cm in the Pole Vault after each round of trials; and the
 - (b) increment of the raising of the bar shall never increase.

These Rules 181.4(a) and (b) shall not apply once the athletes still competing all agree to raise it to a World Record (or other record relevant to the competition) height directly.

After an athlete has won the competition, the height or heights to which the bar is raised shall be decided by the athlete, in consultation with the relevant Judge or Referee.

Note: This Rule does not apply for a Combined Events Competition.

Height Measurement

5. In all vertical jumping events, measurements shall be made, in whole centimetres, perpendicularly from the ground to the lowest part of the upper side of the bar.
6. Any measurement of a new height shall be made before athletes attempt such height. In all cases of Records, the Judges shall also re-check the measurement before each subsequent Record attempt if the bar has been touched since last measured.

Crossbar

7. The crossbar shall be made of fibre-glass, or other suitable material but not metal, circular in cross-section except for the end pieces. It shall be coloured so as to be visible to all sighted athletes. The overall length of the crossbar shall be $4.00\text{m} \pm 0.02\text{m}$ in the High Jump and $4.50\text{m} \pm 0.02\text{m}$ in Pole Vault. The maximum weight of the crossbar shall be 2kg in the High Jump and 2.25kg in Pole Vault. The diameter of the circular part of the crossbar shall be $30\text{mm} \pm 1\text{mm}$.

The crossbar shall consist of three parts - the circular bar and two end pieces, each 30mm-35mm wide and 0.15m-0.20m long for the purpose of resting on the supports of the uprights.

These end pieces shall be circular or semi-circular with one clearly defined flat surface on which the bar rests on the crossbar supports. This flat surface may not be higher than the centre of the vertical cross section of the crossbar. The end pieces shall be hard and smooth. They shall not be of, or covered with rubber or any other material which has the effect of increasing the friction between them and the supports.

The crossbar shall have no bias and, when in place, shall sag a maximum of 20mm in the High Jump and 30mm in Pole Vault.

Control of elasticity: Hang a 3kg weight in the middle of the crossbar when in position. It may sag a maximum of 70mm in the High Jump

and 0.11m in Pole Vault.

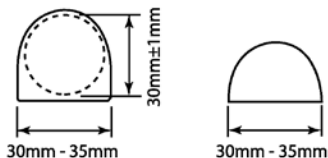

Figure 181 - Alternative ends for crossbar

Placings

8. If two or more athletes clear the same final height, the procedure to decide the places will be the following:
- (a) The athlete with the lowest number of jumps at the height last cleared shall be awarded the higher place.
 - (b) If the athletes are equal following the application of Rule 181.8(a), the athlete with the lowest total of failures throughout the competition up to and including the height last cleared, shall be awarded the higher place.
 - (c) If the athletes are still equal following the application of Rule 181.8(b), the athletes concerned shall be awarded the same place unless it concerns the first place.
 - (d) If it concerns the first place, a jump-off between these athletes shall be conducted in accordance with Rule 181.9, unless otherwise decided, either in advance according to the regulations applying to the competition, or during the competition but before the start of the event by the Technical Delegate(s) or the Referee if no Technical Delegate has been appointed. If no jump-off is carried out, including where the relevant athletes at any stage decide not to jump further, the tie for first place shall remain.

Note: This Rule 181.8(d) does not apply for a Combined Events Competition.

There are a number of ways in which a jump-off may be terminated:

- (a) by provision in advance of the competition set out in the regulations;

(b) by decision during the competition by the Technical Delegate (or Referee if there is no Technical Delegate).;

(c) by decision of the athletes not to jump further prior to or at any stage of the jump-off.

Whilst any decision by the Technical Delegate or Referee not to conduct a jump-off should be made before the start of the event, there may be circumstances where this might not be possible such as where conditions at the place of competition make it impossible or undesirable to begin or continue with a jump-off. The Referee could use his powers under Rules 125 or 180 to deal with this situation.

Jump-off

9. (a) Athletes concerned must jump at every height until a decision is reached or until all of the athletes concerned decide not to jump further.
- (b) Each athlete shall have one jump at each height.
- (c) The jump-off shall start at the next height determined in accordance with Rule 181.1 after the height last cleared by the athletes concerned.
- (d) If no decision is reached the bar shall be raised if more than one athlete concerned were successful, or lowered if all of them failed, by 2cm for the High Jump and 5cm for the Pole Vault.
- (e) If an athlete is not jumping at a height he automatically forfeits any claim to a higher place. If only one other athlete then remains he is declared the winner regardless of whether he attempts that height.

High Jump - Example

Heights announced by the Chief Judge at the beginning of competition: 1.75m; 1.80m; 1.84m; 1.88m; 1.91m; 1.94m; 1.97m; 1.99m...

Athlete	Heights							Failures	Jump Off			Pos
	1.75m	1.80m	1.84m	1.88m	1.91m	1.94m	1.97m		1.91m	1.89m	1.91m	
A	O	XO	O	XO	X-	XX	2	X	O	X	2	
B	-	XO	-	XO	-	-	XXX	2	X	O	O	1
C	-	O	XO	XO	-	XXX	2	X	X		3	
D	-	XO	XO	XO	XXX		3				4	

A, B, C and D all cleared 1.88m.

Rules 181.8 and 181.9 now come into operation; the Judges add up the total number of failures, up to and including the height last cleared, i.e. 1.88m.

"D" has more failures than "A", "B" or "C", and is therefore awarded fourth place. "A", "B" and "C" are still equal and as this concerns the first place, they shall jump at 1.91m which is the next height after the height last cleared by the athletes concerned.

As all the athletes failed, the bar is lowered to 1.89m for another jump-off. As only "C" failed to clear 1.89m, the two other athletes, "A" and "B" shall have a third jump-off at 1.91m which only "B" cleared and is therefore declared the winner.

When an athlete unilaterally decides to withdraw from a jump-off, the other athlete (if only one remains) will be declared the winner in accordance with Rule 181.9(e). It is not necessary for that athlete to attempt the applicable height. Where more than one athlete remains in the jump-off, the jump-off continues with those athletes, with the athlete who withdrew being placed according to his then finishing place, he having forfeited any right to any higher placing, including first, then remaining.

Extraneous Forces

10. When it is clear that the bar has been displaced by a force not associated with an athlete (e.g. a gust of wind)
if such displacement occurs after an athlete has cleared the bar without touching it, then the trial shall be considered successful, or
if such displacement occurs under any other circumstance, a new trial shall be awarded.

RULE 182 HIGH JUMP

Competition

1. An athlete shall take off from one foot.
2. An athlete fails if:
 - (a) After the jump, the bar does not remain on the supports because of the action of the athlete whilst jumping; or
 - (b) He touches the ground including the landing area beyond the vertical plane through the nearer edge of the crossbar, either between or outside the uprights with any part of his body,

without first clearing the bar. However, if when he jumps, an athlete touches the landing area with his foot and in the opinion of the Judge, no advantage is gained, the jump for that reason shall not be considered a failure.

Note: To assist in the implementation of this Rule a white line 50mm wide shall be drawn (usually by adhesive tape or similar material) between points 3m outside of each upright, the nearer edge of the line being drawn along the vertical plane through the nearer edge of the crossbar.

- (c) He touches the crossbar or the vertical section of the uprights when running up without jumping.

Runway and Take-off Area

3. The minimum width of the runway shall be 16m and the minimum length of the runway shall be 15m except in competitions held under Rules 1.1(a), (b), (c), (e) and (f), where the minimum length shall be 25m.
4. The maximum overall downward inclination in the last 15m of the runway and take-off area shall not exceed 1:250 (0.4%) along any radius of the semi-circular area centred midway between the uprights and having the minimum radius specified in Rule 182.3. The landing area should be placed so that the athlete's approach is up the inclination.
5. The take-off area shall be level or any inclination shall be in accordance with the requirements of Rule 182.4 and the IAAF Track and Field Facilities Manual.

Apparatus

6. Any style of uprights or posts may be used, provided they are rigid. They shall have supports for the crossbar firmly fixed to them. They shall be sufficiently tall as to exceed the actual height to which the crossbar is raised by at least 0.10m. The distance between the uprights shall be not less than 4.00m nor more than 4.04m.
7. The uprights or posts shall not be moved during the competition unless the Referee considers that either the take-off or landing area has become unsuitable. In such a case, the change shall be made only after a round of trials has been completed.

8. The crossbar supports shall be flat and rectangular, 40mm wide and 60mm long. They shall be firmly fixed to the uprights and immovable during the jump and shall each face the opposite upright. The ends of the crossbar shall rest on them in such a manner that, if the crossbar is touched by an athlete, it will easily fall to the ground, either forwards or backwards. The surface of the supports shall be smooth.

The supports shall not be of, or covered with, rubber or with any other material which has the effect of increasing the friction between them and the surface of the crossbar, nor may they have any kind of springs.

The supports shall be the same height above the take-off area immediately below each end of the crossbar.

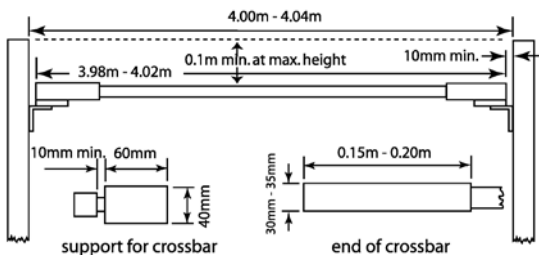

Figure 182 - High Jump uprights and crossbar

9. There shall be a space of at least 10mm between the ends of the crossbar and the uprights.

Landing Area

10. For competitions under Rules 1.1(a), (b), (c), (e) and (f), the landing area shall be not smaller than 6m long x 4m wide x 0.7m high behind the vertical plane of the crossbar.

Note: The uprights and landing area should also be designed so that there is a clearance of at least 0.1m between them when in use, to avoid displacement of the crossbar through a movement of the landing area causing contact with the uprights.

For other competitions, the landing area should measure not less than 5m long x 3m wide x 0.7m high.

Team of Officials

For a High Jump event, it is recommended to allocate the available officials as follows:

(1) The Chief Judge will watch over the whole of the event and verify the measurements. He must be provided with two flags - white to indicate if the trial is valid and red if it is a failure. He must place himself so as to manage two matters in particular:

(a) Frequently it happens that the cross-bar having been touched by an athlete trembles on the supports. The Chief Judge, depending on the position of the cross-bar, must decide when the vibrating of the bar must be stopped and the appropriate flag raised – particularly the special situations as covered in Rule 181.10 and

(b) Since the athlete may not touch the crossbar, the vertical section of the uprights or ground beyond the vertical plane of the nearer edge of the crossbar it is important to keep a watch on the position of the athletes feet in situations where when deciding not to complete a trial he runs to the side or goes “under” the bar.

(2) Judges (1) and (2) on either side of the landing area and slightly standing back in charge of replacing the cross-bar when it falls and assisting the Chief Judge in applying the above Rules.

(3) Judge - a recorder scoring the results sheet and calling each athlete (and the one who is to follow).

(4) Judge in charge of the scoreboard (trial-number-result).

(5) Judge in charge of the clock indicating to the athletes that they have a certain time to take their trial.

(6) Judge in charge of athletes.

Note (i): This is the traditional setting-up of the officials. In major competitions, where a data system and electronic scoreboards are available, specialised personnel are certainly required. To be clear in these cases, the progress and scoring of a Field Event is followed by both the recorder and by the data system.

Note (ii): Officials and equipment must be placed in such a way as not to obstruct the athlete’s way nor impede the view of the spectators.

Note (iii): A space must be reserved for a wind-sock to indicate the wind direction and strength.

RULE 182 S 1 UKA SUPPLEMENT HIGH JUMP LANDING AREA

The landing area should measure at least 5m long (that is at the take-off side) by 3m wide. The minimum depth of the landing area shall be 0.6m.

RULE 183 POLE VAULT

Competition

1. Athletes may have the crossbar moved only in the direction of the landing area so that the edge of the crossbar nearest the athlete can be positioned at any point from that directly above the back end of the box to a point 80cm in the direction of the landing area.

An athlete shall, before the competition starts, inform the appropriate official of the position of the crossbar he requires for his first trial and this position shall be recorded.

If subsequently an athlete wants to make any changes, he should immediately inform the appropriate official before the crossbar has been set in accordance with his initial wishes. Failure to do this shall lead to the start of his time limit.

Note: A line, 10mm wide and of distinguishable colour, shall be drawn at right angles to the axis of the runway, in line with the back end of the box ("zero" line). A similar line, up to 50mm wide, shall appear on the surface of the landing area and be prolonged as far as the outside edge of the uprights. The edge of the line nearer to the approaching athlete coincides with the back end of the box.

2. An athlete fails if:
 - (a) after the vault, the bar does not remain on both pegs because of the action of an athlete whilst vaulting; or
 - (b) he touches the ground, including the landing area, beyond the vertical plane through the back end of the box with any part of his body or with the pole, without first clearing the bar; or
 - (c) after leaving the ground, he places his lower hand above the upper one or moves the upper hand higher on the pole; or
 - (d) during the vault, he steadies or replaces the bar with his hand(s).

Note (i): It is not a failure if an athlete runs outside the white lines marking the runway at any point.

Note (ii) It is not a failure if the pole touches the landing mats, in the course of a trial, after properly being planted in the box.

The following should be noted in applying and interpreting Rule 183.2: (a) the bar must be dislodged because of the action of the athlete "whilst vaulting". So, if the athlete after correctly retrieving his pole (so as not to infringe Rule 183.4) were then to hit the crossbar or the uprights with the pole so that it was dislodged, this would not amount to a failure since it was not because of the action of the athlete whilst vaulting, unless the crossbar was still moving and, as a result, the Judge had not yet raised the white flag;

(b) to take into account the effect of Note (ii) as there will be many occasions when the pole on bending will touch the landing area beyond the zero line;

(c) to be aware of the possibility that the athlete can actually take-off in such a way that his body or the bend of the pole will penetrate the vertical plane through the zero line but then he returns to the runway without attempting to clear the bar. Provided that he has time left for his trial and he did not touch the ground beyond the zero line, he may continue with the trial;

(d) Judges must take particular care to detect whether any action prohibited under Rule 183.2(d) has occurred. Not only does it mean that the relevant Judge must keep an eye on the vaulter throughout the vault, but he must determine that such action was not merely incidental touching as the athlete cleared the bar. In general for (d) to be applied, there should be some direct action on behalf of the athlete to steady or replace the bar.

3. Athletes may, during the competition, place a substance on their hands or on the pole, in order to obtain a better grip. The use of gloves is permitted.

Whilst there is no prohibition on wearing gloves or the use of permitted substances on gloves, this practice should be monitored by Referees in case the practice causes concern and gives rise to possible issue of unfair assistance.

4. After the release of the pole, no one including the athlete shall be allowed to touch the pole unless it is falling away from the bar or uprights. If it is touched, however, and the Referee is of the opinion that, but for the intervention, the bar would have been knocked off, the vault shall be recorded as a failure.

This is one of the few Rules where behaviour by an official can result in a failure being called. It is important therefore that the upright judges are diligent in ensuring that they do not touch or catch a pole unless it is clearly falling away from the cross bar and/or uprights.

5. If, in making a trial, an athlete's pole is broken, it shall not be counted as a failure and he shall be awarded a new trial.

Runway

6. The minimum length of the runway, measured from the “zero” line, shall be 40m and where conditions permit, 45m. It shall have a width of $1.22\text{m} \pm 0.01\text{m}$ and shall be marked by white lines 50mm in width.

Note: For all tracks constructed before 1 January 2004 the runway may have a width of maximum 1.25m. However, when such a runway is fully resurfaced, the lane width shall comply with this Rule.

7. The maximum lateral inclination of the runway should be 1:100 (1%) unless special circumstances exist which justify the IAAF providing an exemption and, in the last 40m of the runway, the overall downward inclination in the direction of running shall not exceed 1:1000 (0.1%).

Apparatus

8. The take-off for the Pole Vault shall be from a box. It shall be constructed of suitable material, with rounded or soft upper edges and shall be sunk level with the runway. It shall be 1.00m in length, measured along the inside of the bottom of the box, 0.60m in width at the front end and tapering to 0.15m in width at the bottom of the stop board. The length of the box at runway level and the depth of the stop board are determined by the angle of 105° formed between the base and the stop board. (Tolerances on dimensions and angles:

of the landing area. The pegs shall be without notches or indentations of any kind, of uniform thickness throughout and not more than 13mm in diameter.

They shall not extend more than 55mm from the supporting members, which shall be smooth. The vertical peg backings, which shall also be smooth and be constructed in a way that the crossbar cannot rest on the top of them, shall extend 35mm-40mm above the pegs.

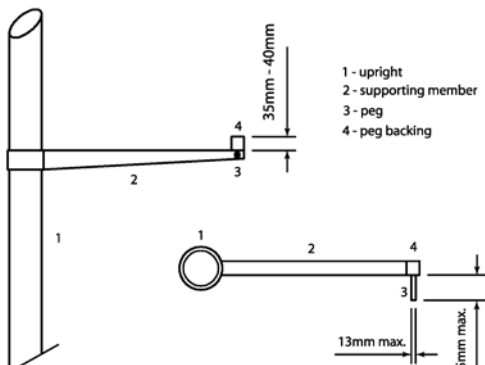

Figure 183b- Pole Vault crossbar support
(view from landing area and top view)

The distance between the pegs shall be 4.28m-4.37m. The pegs shall not be of, or covered with, rubber or with any other material which has the effect of increasing the friction between them and the surface of the bar, nor may they have any kind of springs. The pegs should support the bar in the middle of the end pieces.

Note: To lessen the chance of injury to an athlete by his falling on the feet of the uprights, the pegs supporting the crossbar may be placed upon extension arms permanently attached to the uprights, thus allowing the uprights to be placed wider apart, without increasing the length of the crossbar (see Figure 183b).

Vaulting Poles

11. Athletes may use their own poles. No athlete shall use any other athlete's pole except with the consent of the owner.

The pole may be of any material or combination of materials and of any length or diameter, but the basic surface must be smooth.

The pole may have layers of tape at the grip end (to protect the hand) and of tape and/or any other suitable material at the bottom end (to protect the pole). Any tape at the grip end must be uniform except for incidental overlapping and must not result in any sudden change in diameter, such as the creation of any "ring" on the pole.

Only "regular" taping in accordance with the Rule is allowed at the grip end of the pole - rings, loops and the like are not permitted. There is no restriction on how far up or down the pole such taping extends but it should be for the purpose for which it is intended - to protect the hand. There is however no restriction at the bottom end of the pole and in general any form of taping or protection is permitted there - provided it does not give the athlete any advantage.

Landing Area

12. For competitions under Rules 1.1(a), (b), (c), (e) and (f), the landing area shall be not smaller than 6m long (behind the zero line and excluding the front pieces) x 6m wide x 0.8m high. The front pieces must be at least 2m long.

The sides of the landing area nearest to the box shall be placed 0.10m to 0.15m from the box and shall slope away from the box at an angle of approximately 45° (see Figure 183c).

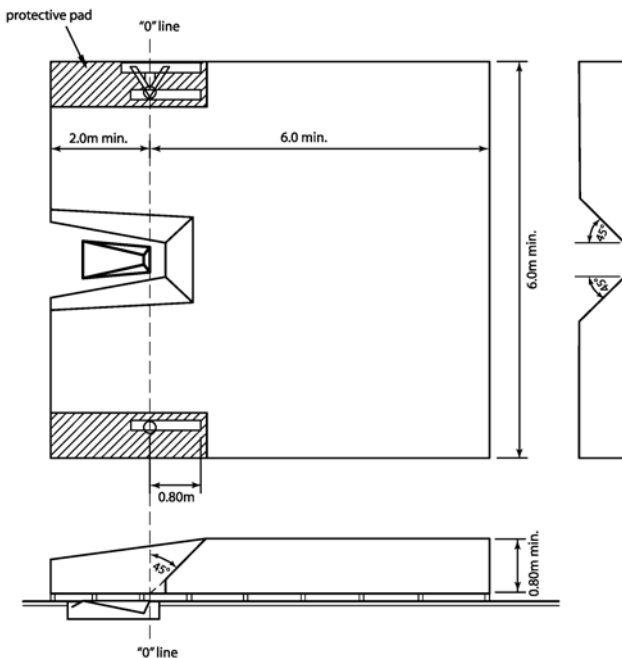

Figure 183c - Pole Vault landing area (top and side views)

(a) Frequently it happens that the cross-bar having been touched by an athlete trembles on the supports. The Chief Judge, depending on the position of the cross-bar, must decide when the vibrating of the bar must be stopped and the appropriate flag raised – particularly the special situations covered in Rule 181.10 and 183.4 and

(b) Since before the take-off, the athlete may not touch the ground beyond the vertical plane through the back end of the box he must place himself in such manner as to be able to determine this.

(2) Judges (1) and (2), on either side in line with the back of the box, in charge of replacing the cross-bar when it falls, assisting the Chief Judge in applying the above Rules. They are also responsible for the correct

positioning of the crossbar as notified by the recorder according to the wishes of the athlete.

(3) Judge - a recorder noting the upright positions requested by the athletes, scoring the results sheet and calling the crossbar position and then each athlete (and the one who is to follow).

(4) Judge in charge of the scoreboard (trial-number-result).

(5) Judge in charge of the clock indicating to the athletes that they have a certain time to take their trial.

(6) Judge in charge of athletes.

Note (i): This is the traditional setting-up of the officials. In major competitions, where a data system and electronic scoreboards are available, specialised personnel are certainly required. To be clear in these cases, the progress and scoring of a Field Event is followed by both the recorder and by the data system.

Note (ii): Officials and equipment must be placed in such a way as not to obstruct the athlete's way nor impede the view of the spectators.

Note (iii): A space must be reserved for a wind-sock to indicate the wind direction and strength.

B. HORIZONTAL JUMPS

RULE 184 GENERAL CONDITIONS – HORIZONTAL JUMPS

Runway

1. The minimum length of the runway, measured from the relevant take-off line shall be 40m and, where conditions permit, 45m. It shall have a width of $1.22\text{m} \pm 0.01\text{m}$ and shall be marked by white lines 50mm in width.

Note: For all tracks constructed before 1 January 2004 the runway may have a width of maximum 1.25m. However when such a runway is fully resurfaced, the lane width shall comply with this Rule.

2. The maximum lateral inclination of the runway should be 1:100 (1%) unless special circumstances exist which justify the IAAF providing an exemption and, in the last 40m of the runway, the overall downward inclination in the direction of running shall not exceed 1:1000 (0.1%).

Take-off Board

3. The take-off shall be marked by a board sunk level with the runway and the surface of the landing area. The edge of the board which is nearer to the landing area shall be the take-off line. Immediately beyond the take-off line there shall be placed a plasticine indicator board for the assistance of the Judges.
4. The take-off board shall be rectangular, made of wood or other suitable rigid material in which the spikes of an athlete's shoe will grip and not skid and shall measure $1.22\text{m} \pm 0.01\text{m}$ long, $0.20\text{m} \pm 0.002\text{m}$ wide and not more than 0.10m deep. It shall be white.
5. The plasticine indicator board shall consist of a rigid board, $0.10\text{m} \pm 0.002\text{m}$ wide and $1.22\text{m} \pm 0.01\text{m}$ long made of wood or any other suitable material and shall be painted in a contrasting colour to the take-off board. Where possible, the plasticine should be of a third contrasting colour. The board shall be mounted in a recess or shelf in the runway, on the side of the take-off board nearer the landing area. The surface shall rise from the level of the take-off board to a height of $7\text{mm} \pm 1\text{mm}$. The edges shall either slant at an angle of 45° with the edge nearer to the runway covered with a plasticine

layer along its length 1mm thick or shall be cut away such that the recess, when filled with plasticine shall slant at an angle of 45° (see Figure 184a).

RULE 184 S 1 UKA SUPPLEMENT - PLASTICINE

NOTE: For the avoidance of doubt the plasticine is deemed to be the ground.

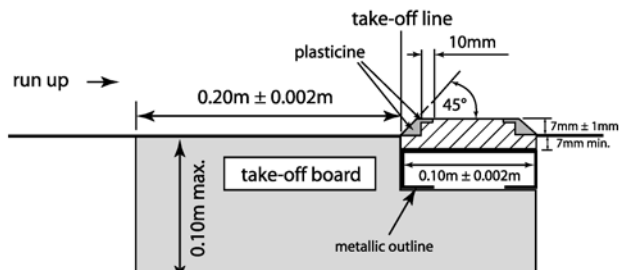

Figure 184a- Take-off board and plasticine indicator board

The upper part of the indicator board shall also be covered for the first 10mm approximately and along its entire length, by a plasticine layer.

When mounted in this recess, the whole assembly shall be sufficiently rigid to accept the full force of the athlete's foot.

The surface of the board beneath the plasticine shall be of a material in which the spikes of an athlete's shoe will grip and not skid.

The layer of plasticine can be smoothed off by means of a roller or suitably shaped scraper for the purposes of removing the footprint of an athlete.

Note: It will be found very helpful to have spare plasticine boards available so that, while a footprint is being eliminated, the competition is not delayed.

Landing Area

6. The landing area shall have a minimum width of 2.75m and a

maximum width of 3m. It shall, if possible, be so placed that the middle of the runway, if extended, would coincide with the middle of the landing area.

Note: When the axis of the runway is not in line with the centre line of the landing area, a tape, or if necessary, two tapes, shall be placed along the landing area so that the above is achieved (see Figure 184b).

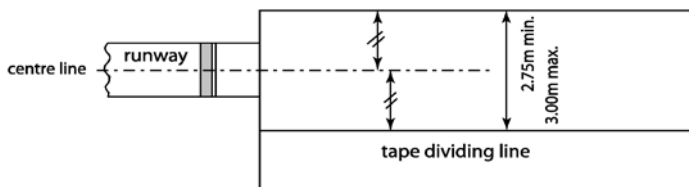

Figure 184b - Centralised Long Jump / Triple Jump landing area

Where new facilities are developed at which it is envisaged that visually impaired athletes will compete, at least one pit should be built with an increased width (3.50m instead of maximum 3.00m as in IAAF Rules) as recommended by IPC.

7. The landing area should be filled with soft damp sand, the top surface of which shall be level with the take-off board.

Distance Measurement

8. In all horizontal jumping events, distances shall be recorded to the nearest 0.01m below the distance measured if the distance measured is not a whole centimetre.
9. The measurement of each jump shall be made immediately after each valid trial (or after an immediate oral protest made under Rule 146.5) from the nearest break in the landing area made by any part of the body, or anything that was attached to the body at the time it made a mark, to the take-off line, or take-off line extended. The measurement shall be taken perpendicular to the take-off line or its extension.

As long as no irregularity has been committed, each trial must be measured whatever the distance reached, including for the reasons that

other trial measurements may become critical in determining countbacks or whether an athlete will proceed to subsequent rounds.

Except where Rule 146.5 is applied, under normal practice no trial during which an irregularity has been committed should be measured. Judges should carefully use their discretion in applying any alternate practice and usually only in special cases.

Unless video measuring is being used, for every valid trial a marker (usually metal) should be placed in a vertical position at the place of the imprint left by the athlete in the landing area nearest to the take-off line. The marker is passed through the loop at the end of the graduated metal tape so that the “zero” is on the mark. The tape should be pulled out horizontally taking care not to place it on any rise in the ground.

Wind Measurement

10. The wind gauge shall be the same as described in Rules 163.8 and 163.9. It shall be operated as described in Rules 163.11 and 184.12 and read as per Rule 163.13.
11. The relevant Field Events Referee shall ensure that the wind gauge is placed 20m from the take-off line. The measuring plane shall be positioned $1.22\text{m} \pm 0.05\text{m}$ high and not more than 2m away from the runway.
12. The wind velocity shall be measured for a period of 5 seconds from the time an athlete passes a mark placed alongside the runway, for the Long Jump 40m from the take-off line and for the Triple Jump 35m. If an athlete runs less than 40m or 35m, as appropriate, the wind velocity shall be measured from the time he commences his run.

RULE 185 LONG JUMP

Competition

1. An athlete fails if:
 - (a) he while taking off, touches the ground (including any part of the plasticine board) beyond the take-off line with any part of his body, whether running up without jumping or in the act of jumping; or
 - (b) he takes off from outside either end of the board, whether beyond or before the extension of the take-off line; or

- (c) he employs any form of somersaulting whilst running up or in the act of jumping; or
 - (d) after taking off, but before his first contact with the landing area, he touches the runway or the ground outside the runway or outside the landing area; or
 - (e) in the course of landing (including any overbalancing), he touches the border of, or the ground outside, the landing area closer to the take-off line than the nearest break made in the sand; or
 - (f) he leaves the landing area in any manner other than that described in Rule 185.2.
2. When leaving the landing area, an athlete's first contact by foot with its border or the ground outside shall be further from the take-off line than the nearest break in the sand (which may be any mark made on overbalancing completely inside the landing area or when walking back closer to the take-off line than the initial break on landing).

Note: This first contact is considered leaving.

3. An athlete shall not be regarded to have failed if:
- (a) he runs outside the white lines marking the runway at any point; or
 - (b) except as described in Rule 185.1(b), he takes off before reaching the board; or
 - (c) under Rule 185.1(b) a part of his shoe / foot is touching the ground outside either end of the take-off board, before the take-off line; or
 - (d) if in the course of landing, he touches, with any part of his body, or anything attached to it at that moment, the border of, or the ground outside the landing area, unless such contact contravenes Rule 185.1(d) or (e); or
 - (e) he walks back through the landing area after having left the landing area in the manner described in Rule 185.2.

Take-off Line

- 4. The distance between the take-off line and the far end of the landing area shall be at least 10m.
- 5. The take-off line shall be placed between 1m and 3m from the nearer end of the landing area.

Team of Officials

For a Long Jump or Triple Jump event, it is recommended to allocate the available officials as follows:

- (1) The Chief Judge will watch over the whole of the event.
- (2) Judge checking whether the take-off has been made correctly and measuring the trial. He must be provided with two flags - white to indicate if the trial is valid and red if it is a failure. When the jump has been measured, it is advised that the judge stands in front of the take-off board, holding the red flag, while the landing area is levelled and, if relevant, the plasticine board is replaced. A cone may be used instead or in addition. (In some competitions this position is assumed by the Chief Judge of the event.)
- (2) Judge at the landing point determining the position of the nearest break in the landing area to the take-off line, to insert the spike/prism and then, if a tape is being used, hold the tape on the 0. When video measuring is being used, no judge will normally be required on site for this purpose. When an optic system of measuring is being used on site, two judges are needed at the landing point, one to plant the marker in the sand, the other one to read the result on the optic apparatus.
- (3) Judge - a recorder scoring the results sheet and calling each athlete (and the one who is to follow).
- (4) Judge in charge of the scoreboard (trial-number-result).
- (5) Judge in charge of the wind-gauge positioned at a point 20 metres from the take-off board.
- (6) one or more Judges or assistants in charge of levelling the landing area after each trial.
- (7) Judge or an assistant in charge of replacing the plasticine.
- (8) Judge in charge of the clock indicating to the athletes that they have a certain time to take their trial.
- (9) Judge in charge of athletes.

Note (i): This is the traditional setting-up of the officials. In major competitions, where a data system and electronic scoreboards are available, specialised personnel are certainly required. To be clear in these cases, the progress and scoring of a Field Event is followed by both the recorder and by the data system.

Note (ii): Officials and equipment must be placed in such a way as not to obstruct the athlete's way nor impede the view of the spectators.

Note (iii): A space must be reserved for a wind-sock to indicate the wind direction and strength.

RULE 186 TRIPLE JUMP

Rules 184 and 185 apply to Triple Jump with the following variations:

Competition

1. The Triple Jump shall consist of a hop, a step and a jump in that order.
2. The hop shall be made so that an athlete lands first on the same foot as that from which he has taken off; in the step he shall land on the other foot, from which, subsequently, the jump is performed. It shall not be considered a failure if an athlete, while jumping, touches the ground with the "sleeping" leg.

Note: Rule 185.1(d) does not apply to the normal landings from the hop and step phases.

It should be noted that it is not a failure (for that reason alone) if the athlete:

- (a) touches the white lines or the ground outside between the take-off line and the landing area; or
- (b) if the athlete lands in the pit in the step phase through no fault of his own (i.e. if the Judge incorrectly indicated the take-off board) - in which such case the Referee would normally offer the athlete a substitute trial. It is, however a failure if the landing of the jump is not within the landing area.

Take-off Line

3. The distance between the take-off line for men and the far end of the landing area shall be at least 21m.
4. For International Competitions, there should be a separate take-off board for men and women. The take-off line shall not be less than 13m for men and 11m for women from the nearer end of the landing area. For any other competition, this distance shall be appropriate for the level of competition.
5. Between the take-off board and the landing area there shall, for the step and jump phases, be a take-off area of 1.22m \pm 0.01m wide providing firm and uniform footing.

|| *Note: For all tracks constructed before 1 January 2004, this take-off area may have a width of maximum 1.25m. However when such a runway is fully resurfaced, the lane width shall comply with this Rule.*

C. THROWING EVENTS

RULE 187 GENERAL CONDITIONS – THROWING EVENTS

Official Implements

1. In all International Competitions, the implements used shall comply with current IAAF specifications. Only IAAF certified implements may be used. The following table shows the implement to be used by each age group:

Implement	Girls U18	Women U20/Senior	Boys U18	Men U20	Men Senior
Shot	3.000kg	4.000kg	5.000kg	6.000kg	7.260kg
Discus	1.000kg	1.000kg	1.500kg	1.750kg	2.000kg
Hammer	3.000kg	4.000kg	5.000kg	6.000kg	7.260kg
Javelin	500g	600g	700g	800g	800g

Note: The current standard forms required to be used for the certification and renewal application as well as the Certification System Procedures are available from the IAAF Office, or may be downloaded from the IAAF website.

2. Except as provided below, all such implements shall be provided by the Organisers. The Technical Delegate(s) may, based on the applicable regulations of each competition, allow athletes to use their own personal implements or those provided by a supplier, provided that such implements are IAAF certified, checked and marked as approved by the Organisers before the competition and made available to all athletes. Such implements will not be accepted if the same model is already on the list of those provided by the Organisers.

Note: “IAAF certified” implements may include older models that previously held a certificate but are not in production any longer.

RULE 187 S 1 UKA SUPPLEMENT IMPLEMENTS

Competitors may use any implements provided for general use. Subject to any regulations laid down by the Promoting Body, competitors who wish to use their own implements must submit them to the Referee for approval. An athlete shall not use another’s implement without the owner’s prior permission.

RULE 187 S 2 UKA SUPPLEMENT SAFETY

In order to avoid accidents the central throwing area or the specific safety sector must be roped off as a unit at a height of approximately 1 metre. Alternatively, shot throwing sectors must be roped off at a height of approximately 1 metre and at a minimum distance of 2 metres outside the shot sector lines.

For safety reasons all throws should be preceded by a warning which shall be acknowledged by the event officials before the throw commences.

NOTE: Referees are reminded of the need to ensure that discus, hammer and javelin competitions (including warm-up for these events) are not held at the same time within the central throwing area when the standard of any of the competitors is likely to create possible danger to the officials operating within and alongside the respective sectors of these events.

It is becoming increasingly common for Organisers to provide a lesser range of implements than in the past (largely due to the cost of purchases). This increases the responsibility of Technical Managers and their assistants to closely check all personal implements presented for competitions - to ensure that they comply with the Rules as well as being on the IAAF list of certified products. Implements which do not currently have but have previously had an IAAF certificate may be accepted for competition if they comply with the Rules.

3. No modification shall be made to any implements during the competition.

Assistance

4. The following shall be considered assistance and are therefore not allowed:
 - (a) The taping of two or more fingers together. If taping is used on the hands and fingers, it may be continuous provided that as a result no two or more fingers are taped together in such a way

that the fingers cannot move individually. The taping should be shown to the Chief Judge before the event starts.

- (b) The use of any device of any kind, including weights attached to the body, which in any way provides assistance when making a trial.
- (c) The use of gloves except in the Hammer Throw. In this case, the gloves shall be smooth on the back and on the front and the tips of the glove fingers, other than the thumb, shall be open.
- (d) The spraying or spreading by an athlete of any substance in the circle or on his shoes nor the roughening of the surface of the circle.

Note: If the Judges are aware, they shall direct any athlete not complying with this rule to correct the situation. If the athlete does not, such trial(s) shall be a failure. If a trial is completed before the non-compliance is noticed, the Referee shall decide what action shall be taken. In all cases considered serious enough, Rules 125.5 and 145.2 may also be applied.

- 5. The following shall not be considered assistance and are therefore allowed:
 - (a) The use by an athlete, in order to obtain a better grip, of a suitable substance on his hands only or in the case of a hammer thrower on his gloves. A shot putter may use such substances on his neck.
 - (b) The placement by an athlete, in the Shot Put and Discus Throw, on the implement, chalk or a similar substance.

All substances used on the hands, gloves and on the implements shall be easily removable from the implement using a wet cloth and shall not leave any residue. If this is not followed the note to Rule 187.4 shall be applied.

- (c) The use of taping on the hands and fingers that is not in contravention of Rule 187.4(a).

Throwing Circle

- 6. The rim of the circle shall be made of band iron, steel or other suitable material, the top of which shall be flush with the ground outside. It shall be at least 6mm thick and shall be white. The ground surrounding the circle may be concrete, synthetic, asphalt, wood or any other suitable material.

The interior of the circle may be constructed of concrete, asphalt or some other firm but not slippery material. The surface of this interior shall be level and $20\text{mm} \pm 6\text{mm}$ lower than the upper edge of the rim of the circle.

In the Shot Put, a portable circle meeting these specifications is permissible.

RULE 187 S 3 UKA SUPPLEMENT THROWING CIRCLE

The UKA circle specification shall be used for all new and resurfaced circles. Contact UKA for the latest specification.

- The inside diameter of the circle shall be $2.135\text{m} \pm 0.005\text{m}$ in the Shot Put and the Hammer Throw and $2.50\text{m} \pm 0.005\text{m}$ in the Discus Throw.

The hammer may be thrown from the discus circle provided the diameter of this circle is reduced from 2.50m to 2.135m by placing a circular ring inside.

Note: The circular ring should preferably be coloured other than white so that the white lines required by Rule 187.8 be clearly visible.

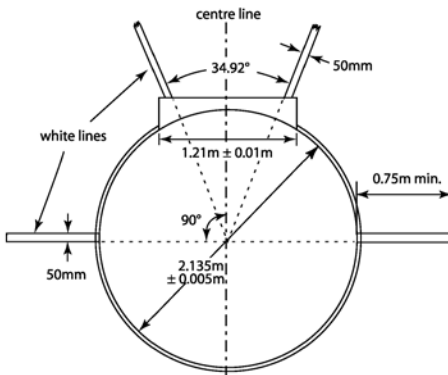

Figure 187A - Layout of Shot Put circle

8. A white line 50mm wide shall be drawn from the top of the rim extending for at least 0.75m on either side of the circle. The white line may be painted or made of wood or other suitable material. The rear edge of the white line shall form a prolongation of a theoretical line through the centre of the circle at right angles to the centre line of the landing sector.

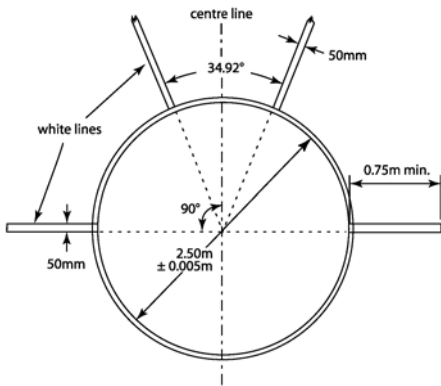

Figure 187b - Layout of Discus Throw circle

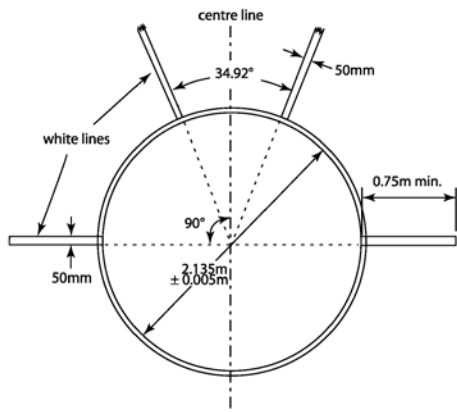

Figure 187c - Layout of Hammer Throw circle

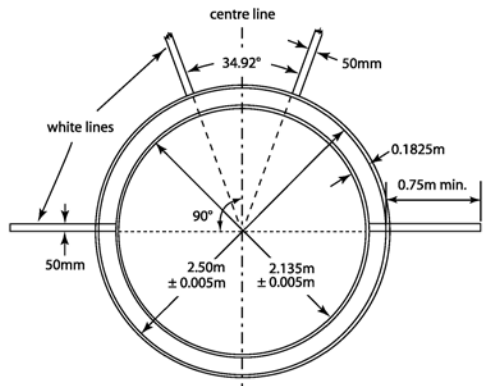

Figure 187d - Layout of concentric circles for Discus and Hammer Throw circle

Javelin Throw Runway

9. The minimum length of the runway shall be 30m except in competitions held under Rules 1.1(a), (b), (c) (e) and (f), where the minimum shall be 33.50m. Where conditions permit, the minimum length should be 36.50m.

It shall be marked by two parallel white lines 50mm wide and 4m apart. The throw shall be made from behind an arc of a circle drawn with a radius of 8m. The arc shall consist of an at least 70mm wide strip painted or made of wood or a suitable non-corrodible material like plastic. It shall be white and be flush with the ground. Lines shall be drawn from the extremities of the arc at right angles to the parallel lines marking the runway. These lines shall be white, at least 0.75m long and at least 70mm wide. The maximum lateral inclination of the runway should be 1:100 (1%) unless special circumstances exist which justify the IAAF providing an exemption and, in the last 20m of the runway, the overall downward inclination in the direction of running shall not exceed 1:1000 (0.1%).

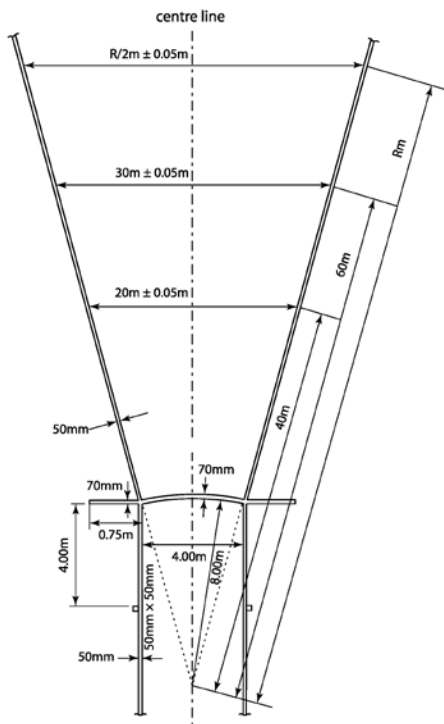

Figure 187e - Javelin Throw runway and landing sector (not to scale)

Landing Sector

10. The landing sector shall consist of cinders or grass or other suitable material on which the implement makes an imprint.
11. The maximum overall downward inclination of the landing sector, in the throwing direction, shall not exceed 1:1000 (0.1%).
12. (a) Except for the Javelin Throw, the landing sector shall be marked with white lines 50mm wide at an angle of 34.92° such that the inner edge of lines, if extended, would pass through the centre of the circle.

Note: The 34.92° sector may be laid out accurately by making the distance between the two points on the sector lines 20m from the centre of the circle 12m ± 0.05m (20m × 0.60m) apart. Thus, for every 1m from the centre of the circle, the distance across shall be increased by 0.60m.

- (b) In the Javelin Throw, the landing sector shall be marked with white lines 50mm wide such that the inner edge of the lines, if extended, would pass through the two intersections of the inner edges of the arc, and the parallel lines marking the runway and intersect at the centre of the circle of which the arc is part (see Figure 187e). The sector angle is thus 28.96°.

The landing sector shall be of an even surface soft enough to ensure that the place of the initial fall of the implement can be clearly established by the Judges. The landing surface should not allow the implement bounce backwards thus creating a risk that the measuring point is obliterated.

Trials

13. In the Shot Put, Discus Throw and Hammer Throw, implements shall be thrown from a circle, and in the Javelin Throw, from a runway. In the case of trials made from a circle, an athlete shall commence his trial from a stationary position inside the circle. An athlete is allowed to touch the inside of the rim. In the Shot Put, he is also allowed to touch the inside of the stop board described in Rule 188.2.

There is no restriction on how, or from which direction, an athlete may enter the circle. The relevant requirement is that once inside he must adopt a stationary position before commencing his trial.

14. It shall be a failure if an athlete in the course of a trial:
- (a) releases the shot or the javelin other than as permitted under Rules 188.1 and 193.1;
 - (b) after he has stepped into the circle and begun to make a throw, touches with any part of his body the top (or the top inside edge) of the rim or the ground outside the circle;
- Note: However, it will not be considered a failure if the touch is made without providing any propulsion and occurs during*

any first rotation at a point completely behind the white line which is drawn outside the circle running, theoretically, through the centre of the circle.

- (c) in the Shot Put, touches with any part of his body any part of the stop board other than its inner side (excluding its top edge which is considered to be part of the top);
- (d) in the Javelin Throw, touches with any part of his body the lines which mark the runway or the ground outside.

Note: It will not be considered a failure if the discus or any part of the hammer strikes the cage after release provided that no other Rule is infringed.

It is clarified that the top inside edges of the rim of the circle and of the stop board are considered to be part of the top of the rim and stop board respectively. This means that should an athlete make contact with the top inside edge of either the rim or the stop-board then he will be considered thereby to have made a failure.

The addition of the Note to Rule 187.14(b) applies to rotational techniques used by athletes in Shot Put, Discus Throw or Hammer Throw. It should be interpreted that any “incidental” touch of the top of the rim or the ground outside in respect of the back half of the circle during the first rotation should not of itself be regarded as a failure. However it is clear that any technique which thereby obtains an advantage through leverage or propulsion would constitute a failure.

15. Provided that, in the course of a trial, the Rules relative to each throwing event have not been infringed, an athlete may interrupt a trial once started, may lay the implement down inside or outside the circle or runway and may leave the circle or runway.

Note: All the moves permitted by this paragraph shall be included in the maximum time for a trial given in Rule 180.17.

In these circumstances, there is no restriction on how, or from which direction, an athlete may leave the circle or runway if he chooses to do. The relevant requirement is that no other Rule is or has already been infringed.

16. It shall be a failure if the shot, the discus, the hammer head or the

head of the javelin in contacting the ground when it first lands touches the sector line or the ground or any object (other than the cage as provided in the Note to Rule 187.14) outside the sector line.

It should be noted that for the purposes of this Rule, the position of the hammer wire or handle is not relevant. For example, the wire could land or be laying on or outside the sector line and it would not matter, provided that the head had landed correctly. The same applies in respect of determining the point from which the measurement is taken under Rule 187.20(a).

17. It shall be a failure if the athlete leaves the circle or runway before the implement has touched the ground, or
- (a) for throws made from a circle, if, when leaving the circle, the athlete's first contact with the top of the rim or the ground outside the circle is not completely behind the white line which is drawn outside the circle running, theoretically, through the centre of the circle;
Note: The first contact with the top of the rim or the ground outside the circle is considered leaving.
 - (b) in the case of the Javelin Throw, if, when leaving the runway, the athlete's first contact with the parallel lines or the ground outside the runway is not completely behind the white line of the arc or the lines drawn from the extremities of the arc at right angles to the parallel lines. Once the implement has touched the ground, an athlete will also be considered to have left the runway correctly, upon making contact with or behind a line (painted, or theoretical and indicated by markers beside the runway) drawn across the runway, four metres back from the end points of the throwing arc. Should an athlete be behind that line and inside the runway at the moment the implement touches the ground, he shall be considered to have left the runway correctly.

The second and third sentences in Rule 187.17(b) are designed to speed up the judging process and not to create an additional method of calling a failure on the athlete. The purpose of the "4m marks" is solely to enable the Judges to raise the white flag and begin measuring the trial once the

athlete retreats behind this point (in the same way as they would do if he had otherwise correctly left the runway). The only requirement is that there is no other reason for calling a failure and that the implement has touched the ground before the white flag is raised. Necessarily, if the athlete for whatever reason never progresses past the “4m marks” when making his throw then the flag can be raised once the implement has landed.

18. After each throw, implements shall be carried back to the area next to the circle or runway and never thrown back.

Distance Measurement

19. In all throwing events, distances shall be recorded to the nearest 0.01m below the distance measured if the distance measured is not a whole centimetre.
20. The measurement of each throw shall be made immediately after each valid trial (or after an immediate oral protest made under Rule 146.5):
 - (a) from the nearest mark made by the fall of the shot, discus and hammer head, to the inside of the circumference of the circle along a line to the centre of the circle;
 - (b) in Javelin Throw, from where the head of the javelin first struck the ground to the inside edge of the arc, along a line to the centre of the circle of which the arc is part.

As long as no irregularity has been committed, each trial must be measured whatever the distance reached, including for the reasons that other trial measurements may become critical in determining countbacks or whether an athlete will proceed to subsequent rounds.

Except where Rule 146.5 is applied, under normal practice no trial during which an irregularity has been committed should be measured. Judges should carefully use their discretion in applying any alternate practice and usually only in special cases.

Unless video measuring is being used, for every valid trial a marker (usually metal) should be placed in a vertical position at the place of the imprint left by the implement in the landing area nearest to the take-off line. The marker is passed through the loop at the end of the graduated metal tape so that the “zero” is on the mark. The tape should be pulled

out horizontally taking care not to place it on any rise in the ground.

RULE 188 SHOT PUT

Competition

1. The shot shall be put from the shoulder with one hand only. At the time an athlete takes a stance in the circle to commence a put, the shot shall touch or be in close proximity to the neck or the chin and the hand shall not be dropped below this position during the action of putting. The shot shall not be taken behind the line of the shoulders.

Note: Cartwheeling techniques are not permitted.

Stop Board

2. The stop board shall be white and made of wood or other suitable material in the shape of an arc so that the inner surface aligns with the inner edge of the rim of the circle and is perpendicular to the surface of the circle. It shall be placed so that its centre coincides with the centre line of the landing sector (see Figure 188), and shall be firmly fixed to the ground or to the concrete surrounding the circle.

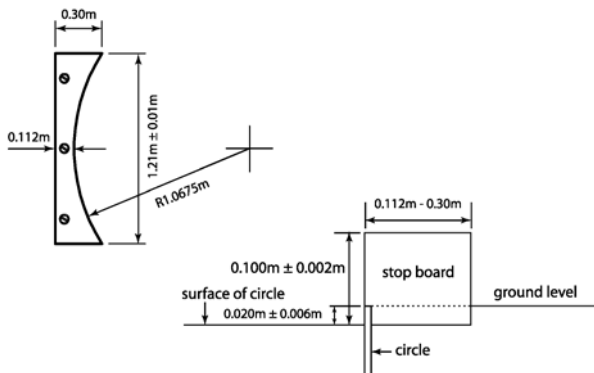

Figure 188 - Shot Put stop board (top and side view)

NOTE: stop board height should read 0.100m +/- 0.008m

Note: Stop boards to the 1983/84 IAAF specifications remain acceptable.

3. The stop board shall measure 0.112m to 0.30m wide, with a chord of $1.21\text{m} \pm 0.01\text{m}$ for an arc of the same radius as the circle and $0.10\text{m} \pm 0.008\text{m}$ high in relation to the level of the inside of the circle adjacent to the stop board.

Shot

4. The shot shall be of solid iron, brass or any metal not softer than brass, or a shell of such metal filled with lead or other solid material. It shall be spherical in shape and its surface finish shall be smooth. Information for manufacturers: to be smooth, the surface average height must be less than $1.6\mu\text{m}$, i.e. a roughness number N7 or less.
5. The shot shall conform to the following specifications:

Minimum weight for admission to competition and acceptance of a Record:	3.000kg	4.000kg	5.000kg	6.000kg	7.260kg
Diameter:					
Minimum	85mm	95mm	100mm	105mm	110mm
Maximum	110mm	110mm	120mm	125mm	130mm

Team of Officials

For a Shot Put event, it is recommended to allocate the available officials as follows:

- (1) The Chief Judge will watch over the whole of the event.
- (2) Two Judges checking whether the put has been made correctly and measuring the trial. One must be provided with two flags - white to indicate if the trial is valid and red if it is a failure. When the put has been measured, it is advised that the Judge stands in the circle holding the red flag, while the implement is returned and the landing area is cleared. A cone may be placed in the circle instead. (In some competitions this position is assumed by the Chief Judge of the event.) Where EDM is not in use the second Judge should pull through and hold the measuring tape in such a way that it passes through the centre of the circle.
- (3) Judge immediately after the throw placing a marker indicating the point from which the trial is to be measured.
- (4) Judge positioning the spike/prism at the point where the marker has

been placed ensuring the tape is on the zero mark.

(5) Judge in charge of retrieving the implements and returning them to the implement stand or placing them in the return chute.

(6) Judge - a recorder scoring the results sheet and calling each athlete (and the one who is to follow).

(7) Judge in charge of the scoreboard (trial-number-result).

(8) Judge in charge of the clock indicating to the athletes that they have a certain time to take their trial.

(9) Judge in charge of athletes.

(10) Judge in charge of the implement stand.

Note (i): This is the traditional setting-up of the officials. In major competitions, where a data system and electronic scoreboards are available, specialised personnel are certainly required. To be clear in these cases, the progress and scoring of a Field Event is followed by both the recorder and by the data system.

Note (ii): Officials and equipment must be placed in such a way as not to obstruct the athlete's way nor impede the view of the spectators.

RULE 188 S 1 UKA SUPPLEMENT
SHOT SPECIFICATIONS FOR NON-IAAF AGE GROUPS

MEN	UNDER 17		UNDER 15	
	Minimum	Maximum	Minimum	Maximum
Weight	5kg	-	4kg	-
Diameter	100mm	120mm	95mm	110mm

	UNDER 13	
Weight	3kg	-
Diameter	90mm	105mm

WOMEN	UNDER 17		UNDER 15	
Weight	3kg	-	3kg	-
Diameter	85mm	110mm	85mm	110mm

	UNDER 13	
Weight	2.72kg	-
Diameter	85mm	95mm

MASTERS	MEN 35–49		MEN 50–59	
Weight	7.26kg	-	6kg	-
Diameter	110mm	130mm	105mm	125mm

	MEN 60–69		MEN 70–79	
Weight	5kg	-	4kg	-
Diameter	100mm	120mm	95mm	110mm

	MEN 80+	
Weight	3kg	-
Diameter	85mm	130mm

	WOMEN 35–49		WOMEN 50 –74	
Weight	4kg	-	3kg	-
Diameter	95mm	110mm	85mm	110mm

	WOMEN 75+	
Weight	2kg	-
Diameter	80mm	110mm

RULE 189 DISCUS THROW

Discus

1. The body of the discus may be solid or hollow and shall be made of wood, or other suitable material, with a metal rim, the edge of which shall be circular. The cross section of the edge shall be rounded in a true circle having a radius of approximately 6mm. There may be circular plates set flush into the centre of the sides. Alternatively, the discus may be made without metal plates, provided that the equivalent area is flat and the measurements and total weight of the implement correspond to the specifications.

Each side of the discus shall be identical and shall be made without indentations, projections or sharp edges. The sides shall taper in a straight line from the beginning of the curve of the rim to a circle of a radius of 25mm to 28.5mm from the centre of the discus.

The profile of the discus shall be designed as follows. From the beginning of the curve of the rim the thickness of the discus increases regularly up to the maximum thickness D . This maximum value is achieved at a distance of 25 mm to 28.5mm from the axis Y . From this point up to the axis Y the thickness of the discus is constant. Upper and lower side of the discus must be identical, also the discus has to be symmetrical concerning rotation around the axis Y .

The discus, including the surface of the rim shall have no roughness and the finish shall be smooth (see Rule 188.4) and uniform throughout.

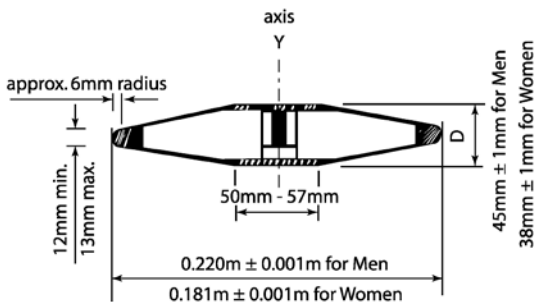

Figure 189 – Discus

2. The discus shall conform to the following specifications:

Minimum weight for admission to competition and acceptance of a Record:

	1.000kg	1.500kg	1.750kg	2.000kg
Outside diameter of metal rim:				
Minimum	180mm	200mm	210mm	219mm
Maximum	182mm	202mm	212mm	221mm
Diameter of metal plate or flat centre area:				
Minimum	50mm	50mm	50mm	50mm
Maximum	57mm	57mm	57mm	57mm
Thickness of metal plate or flat centre area:				
Minimum	37mm	38mm	41mm	44mm
Maximum	39mm	40mm	43mm	46mm
Thickness of metal rim (6mm from edge):				
Minimum	12mm	12mm	12mm	12mm
Maximum	13mm	13mm	13mm	13mm

**RULE 189 S 1 UKA SUPPLEMENT
DISCUS SPECIFICATIONS FOR
NON-IAAF AGE GROUPS**

	Weight kg	Outer Dia of Metal Rim		Dia of Metal Plates		Thickness at Centre		Thickness of Rim at 6mm from the Edge	
		Min mm	Max mm	Min mm	Max mm	Min mm	Max mm	Min mm	Max mm
Men									
Under 17	1.5	200	205	50	57	37	42	12	13
Under 15	1.25	180	182	50	57	37	39	12	13
Under 13	1.0	180	182	50	57	37	39	12	13
Women									
Under 17 and Under 15	1.0	180	182	50	57	37	39	12	13
Under 13 Masters	0.75	145	170	50	57	25	35	10	11
Men 35 - 49	2.0	219	221	50	57	44	46	12	13
Men 50 - 59	1.5	200	205	50	57	37	42	12	13
Men 60+	1.0	180	182	50	57	37	39	12	13
Women 35 - 74	1.0	180	182	50	57	37	39	12	13
Women 75+	0.75	145	170	50	57	25	35	10	11

Team of Officials

For a Discus Throw event, it is recommended to allocate the available officials as follows:

- (1) The Chief Judge will watch over the whole of the event.
- (2) Two Judges checking whether the throw has been made correctly and measuring the trial. One must be provided with two flags - white to indicate if the trial is valid and red if it is a failure. When the throw has been measured, it is advised that the Judge stands at the entrance to the cage holding the red flag, while the implement is returned and the landing area is cleared. A cone may be placed at this point instead. (In some competitions this position is assumed by the Chief Judge of the event.)

Where EDM is not in use the second Judge should pull through and hold the measuring tape in such a way that it passes through the centre of the circle.

(3) Judge immediately after the throw placing a marker indicating the point from which the trial is to be measured. If the implement lands outside the sector either this Judge or the one with the spike/prism (whichever is closer to the line) should indicate this by holding his arm outstretched. No indication is required for a valid trial.

(4) Judge positioning the spike/prism at the point where the marker has been placed ensuring the tape is on the zero mark.

(5) One or more Judges or assistants in charge of retrieving the implements and returning them to the implement stand or placing them in the return device. Where a tape is used for measurement, one of these Judges or assistants should ensure that the tape measure is taut in order to ensure a correct measurement.

(6) Judge - a recorder scoring the results sheet and calling each athlete (and the one who is to follow).

(7) Judge in charge of the scoreboard (trial-number-result).

(8) Judge in charge of the clock indicating to the athletes that they have a certain time to take their trial.

(9) Judge in charge of athletes.

(10) Judge in charge of the implement stand.

Note (i): This is the traditional setting-up of the officials. In major competitions, where a data system and electronic scoreboards are available, specialised personnel are certainly required. To be clear in these cases, the progress and scoring of a Field Event is followed by both the recorder and by the data system.

Note (ii): Officials and equipment must be placed in such a way as not to obstruct the athlete's view nor impede the view of the spectators.

Note (iii): A space must be reserved for a wind-sock to indicate the wind direction and strength.

RULE 190 DISCUS CAGE

1. All discus throws shall be made from an enclosure or cage to ensure the safety of spectators, officials and athletes. The cage specified in this Rule is intended for use when the event takes place in the Field of Play with other events taking place at the same time or when the event takes place outside the Field of Play with spectators present. Where this does not apply, and especially in training areas, a much simpler construction may be satisfactory. Advice is available, on request, from Members or from the IAAF Office.

Note: The hammer cage specified in Rule 192 may also be used for Discus Throw, either by installing 2.135/2.50m concentric circles, or by using the extension of the gates of that cage with a separate discus circle installed in front of the hammer circle.

2. The cage should be designed, manufactured and maintained so as to be capable of stopping a 2kg discus moving at a speed of up to 25 metres per second. The arrangement should be such that there is no danger of ricocheting or rebounding back towards the athlete or over the top of the cage. Provided that it satisfies all the requirements of this Rule, any form of cage design and construction can be used.
3. The cage should be U-shaped in plan as shown in Figure 190. The width of the mouth should be 6m, positioned 7m in front of the centre of the throwing circle. The end points of the 6m wide mouth shall be the inner edge of the cage netting. The height of the netting panels or draped netting at their lowest point should be at least 4m and it should be at least 6m for the 3m nearest the front of the cage on each side. [from 1 January 2020]

Provision should be made in the design and construction of the cage to prevent a discus forcing its way through any joints in the cage or the netting or underneath the netting panels or draped netting.

Note (i): The arrangement of the rear panels/netting is not important provided the netting is a minimum of 3.00m away from the centre of the circle.

Note (ii): Innovative designs that provide the same degree of protection and do not increase the danger zone compared with conventional designs may be IAAF certified.

Note (iii) The cage side, particularly alongside the track, may be lengthened and/or increased in height so as to provide greater protection to athletes competing on the adjoining track during a discus competition.

The netting must be fixed in a way that the width of the mouth is the same at each height of the netting. This applies also for the panels when put into a position according to Rule 192.4 Note (ii).

4. The netting for the cage can be made from suitable natural or synthetic fibre cord or, alternatively, from mild or high tensile steel wire. The maximum mesh size shall be 44mm for cord netting and 50mm for steel wire.

Note: Further specifications for the netting and safety inspection procedures are set out in the IAAF Track and Field Facilities Manual.

5. The maximum danger sector for discus throws from this cage is approximately 69°, when used by both right and left handed throwers in the same competition (calculated by assuming that the discus is released from a circumscribed circle of 1.5m radius). The position and alignment of the cage in the Field of Play is, therefore, critical for its safe use.

Note: The method used to determine the danger zone is illustrated in Figure 190.

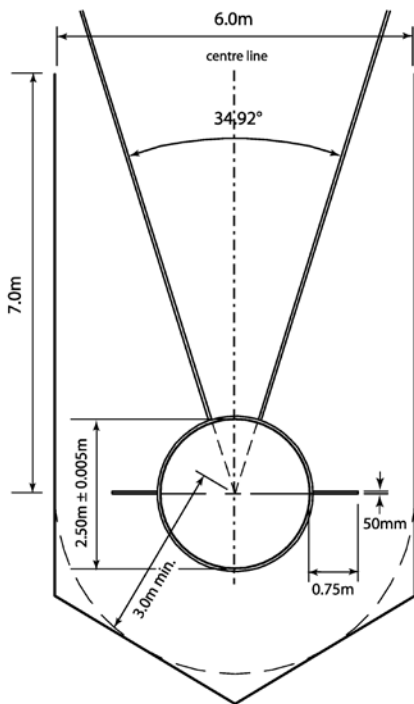

Figure 190 - Cage for Discus Throw only

RULE 191 HAMMER THROW

Competition

1. An athlete, in his starting position prior to the preliminary swings or turns, is allowed to put the head of the hammer on the ground inside or outside the circle.
2. It shall not be considered a failure if the head of the hammer touches the ground inside or outside the circle, or the top of the rim. The

athlete may stop and begin the throw again, provided no other Rule has been breached.

3. If the hammer breaks during a throw or while in the air, it shall not count as a failure, provided the trial was otherwise made in accordance with this Rule. Nor shall it count as a failure if an athlete thereby loses his balance and as a result contravenes any part of this Rule. In both cases the athlete shall be awarded a new trial.

Hammer

4. The hammer shall consist of three main parts: a metal head, a wire and a handle.
5. The head shall be of solid iron, brass or other metal not softer than brass or a shell of such metal filled with lead or other solid material. The centre of gravity of the head shall be not more than 6mm from the centre of the sphere, i.e. - it must be possible to balance the head, less handle and wire, on a horizontal sharp-edged circular orifice 12mm in diameter (see Figure 191a). If a filling is used, this shall be inserted in such manner that it is immovable and complies with the requirement for the centre of gravity.

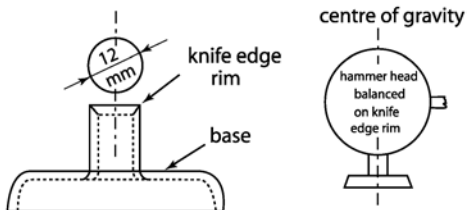

Figure 191a - Suggested apparatus for testing centre of gravity of hammer head

6. The wire shall be a single unbroken and straight length of spring steel wire not less than 3mm in diameter and shall be such that it cannot stretch appreciably while the hammer is being thrown. The wire may be looped at one or both ends as a means of attachment. The wire shall be connected to the head by means of a swivel, which may be either plain or ball bearing.
7. The handle shall be rigid and without hinging joints of any kind. The

total deformation of the handle under a tension load of 3.8kN shall not exceed 3mm. It shall be attached to the wire in such a manner that it cannot be turned within the loop of the wire to increase the overall length of the hammer. The handle shall be connected to the wire by means of a loop. A swivel may not be used.

The handle shall have a symmetric design and may have a curved or straight grip and/or brace. The minimum handle breaking strength shall be 8 kN.

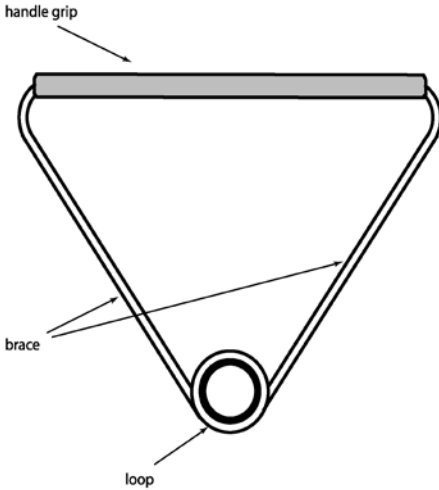

Figure 191b - Generic hammer handle

Note: Other designs complying with the specifications are acceptable.

8. The hammer shall conform to the following specifications:
Minimum weight for admission to competition and acceptance of a Record:

3.000kg 4.000kg 5.000kg 6.000kg 7.260kg

|| Length of hammer measured from inside centre of handle:

Maximum 1195mm 1195mm 1200mm 1215mm 1215mm

Diameter of head:

Minimum 85mm 95mm 100mm 105mm 110mm

Maximum 100mm 110mm 120mm 125mm 130mm

Note: The weight of the implement includes the totality of the hammer head, wire and handle.

Team of Officials

For a Hammer Throw event, it is recommended to allocate the available officials as follows:

(1) The Chief Judge will watch over the whole of the event.

(2) Two Judges checking whether the throw has been made correctly and measuring the trial. One must be provided with two flags - white to indicate if the trial is valid and red if it is a failure. When the throw has been measured, it is advised that the Judge stands at the entrance to the cage holding the red flag, while the implement is returned and the landing area is cleared. A cone may be placed at this point instead. (In some competitions this position is assumed by the Chief Judge of the event.)

Where EDM is not in use the second Judge should pull through and hold the measuring tape in such a way that it passes through the centre of the circle.

(3) Judge immediately after the throw placing a marker indicating the point from which the trial is to be measured. If the implement lands outside the sector either this Judge or the one with the spike/prism (whichever is closer to the line) should indicate this by holding his arm outstretched. No indication is required for a valid trial.

(4) Judge positioning the spike/prism at the point where the marker has been placed ensuring the tape is on the zero mark.

(5) one or more Judges or assistants in charge of retrieving the implements and returning them to the implement stand or placing them in the return device. Where a tape is used for measurement, one of these Judges or assistants should ensure that the tape measure is taut in order

to ensure a correct measurement.

(6) Judge - a recorder scoring the results sheet and calling each athlete (and the one who is to follow).

(7) Judge in charge of the scoreboard (trial-number-result).

(8) Judge in charge of the clock indicating to the athletes that they have a certain time to take their trial.

(9) Judge in charge of athletes.

(10) Judge in charge of the implement stand.

Note (i): This is the traditional setting-up of the officials. In major competitions, where a data system and electronic scoreboards are available, specialised personnel are certainly required. To be clear in these cases, the progress and scoring of a Field Event is followed by both the recorder and by the data system.

Note (ii): Officials and equipment must be placed in such a way as not to obstruct the athlete's way nor impede the view of the spectators.

RULE 191 S 1 UKA SUPPLEMENT
HAMMER SPECIFICATIONS FOR NON-IAAF AGE GROUPS

MEN	UNDER 17		UNDER 15	
	Minimum	Maximum	Minimum	Maximum
Weight Complete	5kg	–	4kg	–
Length of Hammer	–	1200mm	–	1195mm
Diameter of Head	100mm	120mm	95mm	110mm
	UNDER 13			
Weight Complete	3kg	–		
Length of Hammer	–	1195mm		
Diameter of Head	85mm	100mm		
	WOMEN UNDER 17, UNDER 15, UNDER 13			
Weight Complete	3kg	–		
Length of Hammer	–	1195mm		
Diameter of Head	85mm	100mm		
	MASTERS MEN 35–49		MEN 50–59	
Weight Complete	7.26kg	–	6kg	–
Length of Hammer	–	1215mm	–	1215mm
Diameter of Head	110mm	130mm	105mm	125mm
	MEN 60–69		MEN 70–79	
Weight Complete	5kg	–	4kg	–
Length of Hammer	–	1200mm	–	1195mm
Diameter of Head	100mm	120mm	95mm	110mm
	MEN 80 and OVER			
Weight Complete	3kg	–		
Length of Hammer	–	1195mm		
Diameter of Head	85mm	100mm		
	WOMEN 35–49		WOMEN 50–74	
Weight Complete	4kg	–	3kg	–
Length of Hammer	–	1195mm	–	1195mm
Diameter of Head	95mm	110mm	85mm	100mm
	WOMEN 75 and OVER			
Weight Complete	2kg	–		
Length of Hammer	–	1195mm		
Diameter of Head	80mm	90mm		

RULE 192 HAMMER CAGE

1. All hammer throws shall be made from an enclosure or cage to ensure the safety of spectators, officials and athletes. The cage specified in this Rule is intended for use when the event takes place in the Field of Play with other events taking place at the same time or when the event takes place outside the Field of Play with spectators present. Where this does not apply, and especially in training areas, a much simpler construction may be satisfactory. Advice is available on request from Members or from the IAAF Office.
2. The cage should be designed, manufactured and maintained so as to be capable of stopping a 7.260kg hammer head moving at a speed of up to 32 metres per second. The arrangement should be such that there is no danger of ricocheting or rebounding back towards the athlete or over the top of the cage. Provided that it satisfies all the requirements of this Rule, any form of cage design and construction can be used.
3. The cage should be U-shaped in plan as shown in Figure 192a. The width of the mouth should be 6m, positioned 7m in front of the centre of the throwing circle. The end points of the 6m wide mouth shall be the inner edge of the pivoted netting. The height of the netting panels or draped netting at their lowest point shall be at least 7m for the panels/netting at the rear of the cage and at least 10m for the last 2.80m panels to the gate netting pivot points. Provisions should be made in the design and construction of the cage to prevent a hammer forcing its way through any joints in the cage or the netting or underneath the netting panels or draped netting.
Note: The arrangement of the rear panels / netting is not important provided the netting is a minimum of 3.50m away from the centre of the circle.

RULE 192 S 1 UKA SUPPLEMENT HAMMER CAGE

The cage should be U-shaped in plan, consisting of a minimum of netting panels each having a minimum width of 2.74m as shown in the diagram. The width of the mouth should be 6m, positioned 4.2m in front of the

centre of the throwing circle. The end points of the 6m wide mouth shall be the inner edge of the cage netting. The minimum height of these netting panels shall be 7m.

Provision should be made in the design and construction of the cage to prevent a hammer forcing its way through any joints in the cage or the netting. In addition, provision should be made to prevent a hammer sliding along the ground underneath the netting.

4. Two movable netting panels 2m wide shall be provided at the front of the cage, only one of which will be operative at a time. The minimum height of the panels shall be 10m.

RULE 192 S 2 UKA SUPPLEMENT GATE PANELS

Two movable gate panels shall be provided at the front of the cage, only one of which will be operative at a time. The minimum height of the panels shall be 9m.

Note (i): The left hand panel is used for throwers turning anti clockwise, and the right hand panel for throwers turning clockwise. In view of the possible need to change over from one panel to the other during the competition, when both left and right-handed throwers are present, it is essential that this changeover should require little labour and be carried out in the minimum of time.

Note (ii): The end position of both panels is shown in the plan even though only one panel will be closed at any one time during competition. The out of use gate panel must be parallel to the sector lines as shown in the diagram.

Note (iii): When in operation, the movable panel shall be exactly in the position shown. Provision shall therefore, be made in the design of the movable panels to lock them in the operative position. It is recommended to mark (either temporarily or permanently) the operative positions of the panels on the ground.

Note (iv): The construction of these panels and their operation depends on the overall design of the cage and can be sliding,

hinging on a vertical or horizontal axis or dismounting. The only firm requirements are that the panel in operation shall be fully able to stop any hammer striking it and there shall be no danger of a hammer being able to force its way between the fixed and movable panels.

Note (v): Innovative designs that provide the same degree of protection and do not increase the danger zone compared with conventional designs may be IAAF certified.

5. The netting for the cage can be made from suitable natural or synthetic fibre cord or, alternatively, from mild or high tensile steel wire. The maximum mesh size shall be 44mm for cord netting and 50mm for steel wire.

Note: Further specifications for the netting and safety inspection procedures are set out in the IAAF Track and Field Facilities Manual.

6. Where it is desired to use the same cage for Discus Throw, the installation can be adapted in two alternative ways. Most simply, a 2.135m/2.50m concentric circle may be fitted, but this involves using the same surface in the circle for Hammer Throw and Discus Throw. The hammer cage shall be used for Discus Throw by fixing the movable netting panels clear of the cage opening.

For separate circles for Hammer Throw and Discus Throw in the same cage, the two circles shall be placed one behind the other with the centres 2.37m apart on the centre line of the landing sector and with the discus circle at the front. In that case, the movable netting panels shall be used for Discus Throw in order to lengthen the cage sides.

Note: The arrangement of the rear panels/draped netting is not important provided the netting is a minimum of 3.50m away from the centre of concentric circles or the hammer circle in case of separate circles (or 3.00m for cages with separate circles built under the Rule in force before 2004 with the discus circle at the back) (See also Rule 192.4).

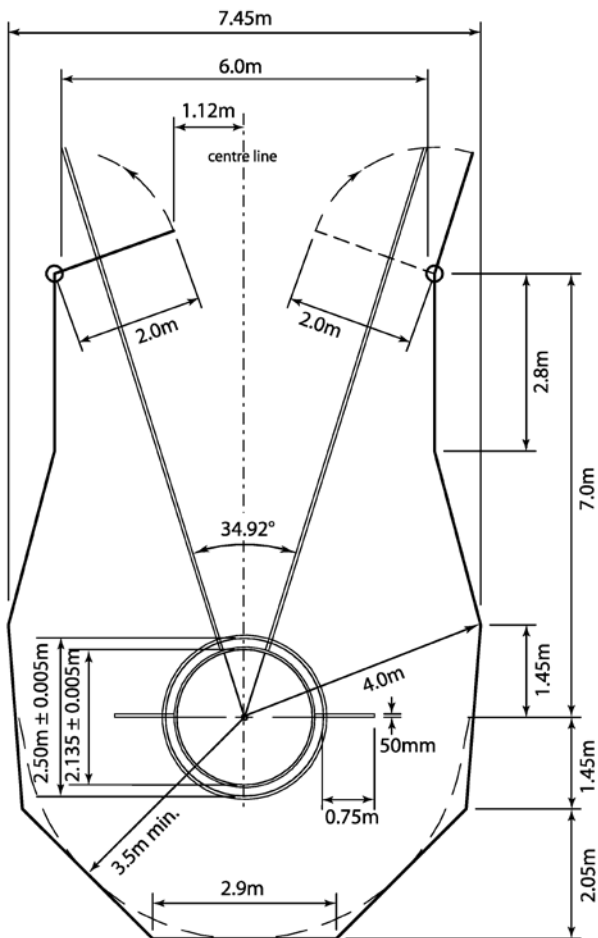

Figure 192a - Cage for Hammer and Discus Throw with concentric circles (Hammer Throw configuration)

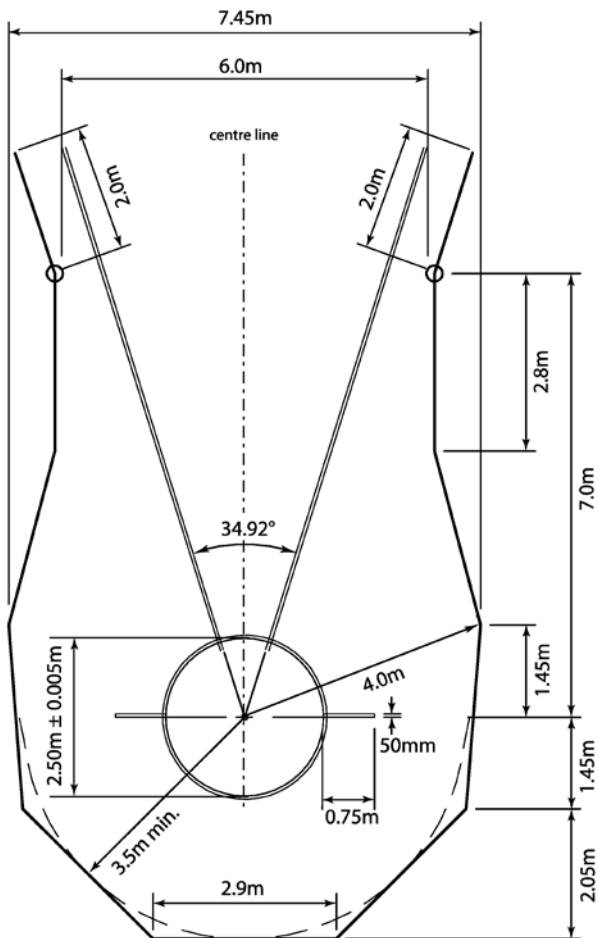

Figure 192b - Cage for Hammer and Discus Throw with concentric circles (Discus Throw configuration)

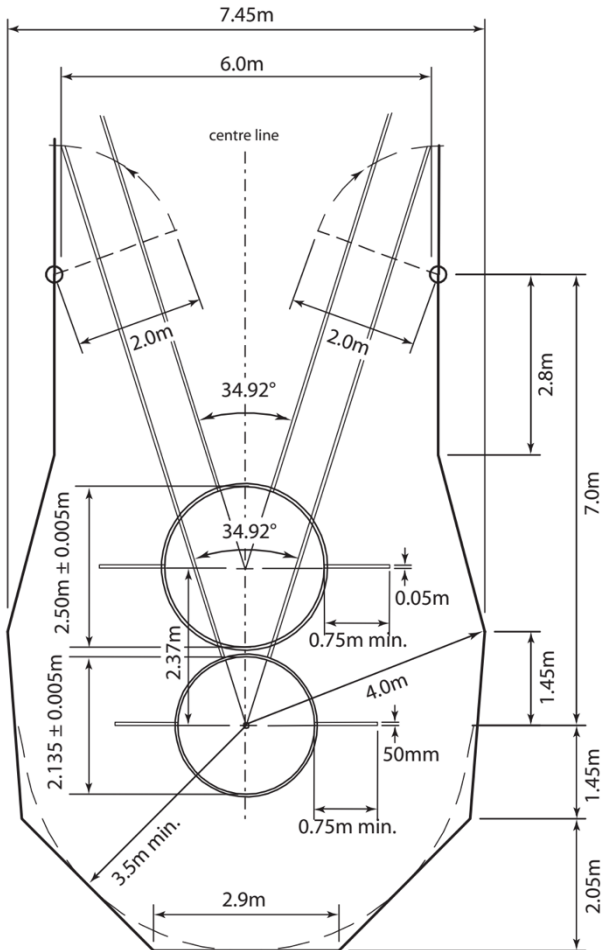

Figure 192c - Cage for Hammer and Discus Throw with separate circles

7. The maximum danger sector for hammer throws from this cage is approximately 53°, when used by both right and left-handed throwers in the same competition (calculated by assuming that the hammer is released from a circumscribed circle of 2.407m radius). The position and alignment of the cage in the Field of Play is, therefore, critical for its safe use.

Note: The method used to determine the danger zone is illustrated in Figure 192a.

RULE 193 JAVELIN THROW

Competition

1. (a) The javelin shall be held at the grip with one hand only. It shall be thrown over the shoulder or upper part of the throwing arm and shall not be slung or hurled. Non-orthodox styles are not permitted.
- (b) A throw shall be valid only if the metal head strikes the ground before any other part of the javelin.
- (c) Until the javelin has been thrown, an athlete shall not at any time turn completely around, so that his back is towards the throwing arc.

Previous references in the Rules to the “tip” of the javelin have been removed and are replaced by a generic reference to the head. This acknowledges that the shape of the head varies greatly, making it harder to separately define the tip. It means that Judges in determining whether the javelin has landed correctly in terms of Rule 187.16 and Rule 193.1(b) and the reference point for measurement in terms of Rule 187.20(b) now have a bigger area with which to assess. But the principles remain as before and there must be some angle on landing, however small, for the throw to be valid. Flat or “tail-first” landings are still to be red flagged.

2. If the javelin breaks during a throw or while in the air, it shall not count as a failure, provided the trial was otherwise made in accordance with this Rule. Nor shall it count as a failure if an athlete thereby loses his balance and as a result contravenes any part of this Rule. In both cases the athlete shall be awarded a new trial.

Javelin

3. The javelin shall consist of three main parts: a shaft, a head and a cord grip.
4. The shaft may be solid or hollow and shall be constructed of metal or other suitable material so as to constitute a fixed and integrated whole. The surface of the shaft shall have no dimples or pimples, grooves or ridges, holes or roughness, and the finish shall be smooth (see Rule 188.4) and uniform throughout.
5. The shaft shall have fixed to it a metal head terminating in a sharp point. The head shall be constructed completely of metal. It may contain a reinforced tip of other metal alloy fixed to the front end of the head provided that the completed head is smooth (see Rule 188.4) and uniform along the whole of its surface. The angle of tip shall not exceed 40 degrees.
6. The cord grip, which shall cover the centre of gravity, shall not exceed the diameter of the shaft by more than 8mm. It may have a regular non-slip pattern surface but without thongs, notches or indentations of any kind. The grip shall be of uniform thickness.
7. The cross-section shall be regularly circular throughout (see Note (i)). The maximum diameter of the shaft shall be immediately in front of the grip. The central portion of the shaft, including the part under the grip, may be cylindrical or slightly tapered towards the rear but in no case may the reduction in diameter, from immediately in front of the grip to immediately behind, exceed 0.25mm. From the grip, the javelin shall taper regularly to the tip at the front and the tail at the rear. The longitudinal profile from the grip to the front tip and to the tail shall be straight or slightly convex (see Note (ii)), and there shall be no abrupt alteration in the overall diameter, except immediately behind the head and at the front and rear of the grip, throughout the length of the javelin. At the rear of the head, the reduction in the diameter may not exceed 2.5mm and this departure from the longitudinal profile requirement may not extend more than 0.3m behind the head.

Note (i): Whilst the cross section throughout should be circular, a maximum difference between the largest and the smallest diameter at any cross section of 2% is permitted. The mean value of these

two diameters, at any nominated cross section, shall meet the specifications of a circular javelin in the tables hereunder.

Note (ii): The shape of the longitudinal profile may be quickly and easily checked using a metal straight edge at least 500mm long and two feeler gauges 0.20mm and 1.25mm thick. For slightly convex sections of the profile, the straight edge will rock while being in firm contact with a short section of the javelin. For straight sections of the profile, with the straight edge held firmly against it, it must be impossible to insert the 0.20mm gauge between the javelin and the straight edge anywhere over the length of contact. This shall not apply immediately behind the joint between the head and the shaft. At this point it must be impossible to insert the 1.25mm gauge.

8. The javelin shall conform to the following specifications:
Minimum weight for admission to competition and acceptance of a Record (inclusive of the cord grip):

	500g	600g	700g	800g
Overall length (L0):				
Minimum	2000mm	2200mm	2300mm	2600mm
Maximum	2100mm	2300mm	2400mm	2700mm
Distance from tip of metal head to centre of gravity (L1):				
Minimum	780mm	800mm	860mm	900mm
Maximum	880mm	920mm	1000mm	1060mm
Distance from tail to centre of gravity (L2):				
Minimum	1120mm	1280mm	1300mm	1540mm
Maximum	1320mm	1500mm	1540mm	1800mm
Length of metal head (L3):				
Minimum	220mm	250mm	250mm	250mm
Maximum	270mm	330mm	330mm	330mm
Width of cord grip (L4):				
Minimum	135mm	140mm.	150mm	150mm
Maximum	145mm	150mm	160mm.	160mm.
Diameter of shaft at thickest point (in front of grip - D0):				
Minimum	20mm	20mm	23mm	25mm
Maximum	24mm	25mm	28mm	30mm

**RULE 193 S 1 UKA SUPPLEMENT
JAVELIN SPECIFICATIONS FOR
NON-IAAF AGE GROUPS**

MEN	UNDER 17		UNDER 15		UNDER 13	
	Min	Max	Min	Max	Min	Max
Weight (incl of cord grip)	700g		600g		400g	
Length	2300mm	2400mm	2200mm	2300mm	1700mm	1950mm
Length of metal head	250mm	330mm	250mm	330mm	200mm	300mm
Distance from tip of metal head to centre of gravity	830mm	1010mm	800mm	920mm	700mm	850mm
Diameter at thickest point	22mm	28mm	20mm	25mm	19mm	24mm
Whipcord Width	150mm	160mm	140mm	150mm	130mm	140mm

WOMEN	UNDER 17 and UNDER 15		UNDER 13		
	Min	Max	Min	Max	
Weight (incl of cord grip)	500g		400g		
Length	2000mm	2100mm	1700mm	1950mm	
Length of metal head	220mm	270mm	200mm	300mm	
Distance from tip of metal head to centre of gravity	720mm	880mm	700mm	850mm	
Diameter at thickest point	20mm	24mm	19mm	24mm	
Whipcord Width	135mm	145mm	130mm	140mm	
MASTERS	MEN	MEN	MEN	MEN	MEN
	35 - 49	50 - 59	60 - 69	70 - 79	80+
Weight (incl of cord grip)	800g	700g	600g	500g	400g
	WOMEN	WOMEN	WOMEN	WOMEN	
	35 - 49	50 - 59	60 - 69	70 - 79	80+
Weight (incl of cord grip)	600g	500g	400g	300g	

9. The javelin shall have no mobile parts or other apparatus, which during the throw could change its centre of gravity or throwing characteristics.
10. The tapering of the javelin to the tip of the metal head shall be such that the angle of the point shall be not more than 40°. The diameter, at a point 0.15m from the tip, shall not exceed 80% of the maximum diameter of the shaft. At the midpoint between the centre of gravity and the tip of the metal head, the diameter shall not exceed 90% of the maximum diameter of the shaft.

11. The tapering of the shaft to the tail at the rear shall be such that the diameter, at the midpoint between the centre of gravity and the tail, shall not be less than 90% of the maximum diameter of the shaft. At a point 0.15m from the tail, the diameter shall be not less than 40% of the maximum diameter of the shaft. The diameter of the shaft at the end of the tail shall not be less than 3.5mm.

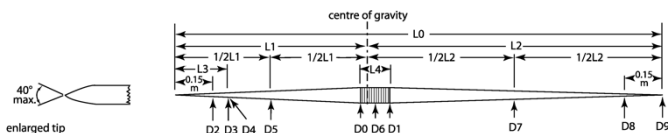

Lengths		Diameters		Maximum	Minimum
L0	Overall	D0	In front of grip	–	–
L1	Tip to C of G	D1	At rear of grip	D0	D0-0.25mm
1/2L1	Half L1	D2	150mm from tip	0.8 D0	–
L2	Tail to C of G	D3	At rear of head	–	–
1/2L2	Half L2	D4	Immediately behind head	–	D3-2.5mm
L3	Head	D5	Half way tip to C of G	0.9 D0	–
L4	Grip	D6	Over grip	D0+8mm	–
		D7	Half way tail to C of G	–	0.9 D0
		D8	150mm from tail	–	0.4 D0
C of G	Centre of Gravity	D9	At tail	–	3.5mm

Note: All measurements of diameters must be to at least 0.1 mm.

Figure 193 - International Javelin

Team of Officials

For a Javelin Throw event, it is recommended to allocate the available officials as follows:

- (1) The Chief Judge will watch over the whole of the event.
- (2) Two Judges checking whether the throw has been made correctly and measuring the trial. One must be provided with two flags - white to indicate if the trial is valid and red if it is a failure. When the throw has been measured, it is advised that the Judge stands on the runway holding the red flag, while the implement is returned and the landing area is cleared. A cone may be placed on the runway instead. (In some competitions this position is assumed by the Chief Judge of the event.)

Where EDM is not in use the second Judge should pull through and hold the measuring tape in such a way that it passes through the 8m point marked on the runway.

(3) one or two Judges immediately after the throw placing a marker indicating the point from which the trial is to be measured. If the implement lands outside the sector either this Judge or the one with the spike/prism (whichever is closer to the line) should indicate this by holding his arm outstretched. An appropriate indication is also required if these Judges determine that the implement has not landed “head first”. It is recommended that some form of signal other than flags is used for this purpose. No indication is required for a valid trial.

(4) Judge positioning the spike/prism at the point where the marker has been placed ensuring the tape is on the zero mark.

(5) one or more Judges or assistants in charge of retrieving the implements and returning them to the implement stand or placing them in the return device. Where a tape is used for measurement, one of these Judges or assistants should ensure that the tape measure is taut in order to ensure a correct measurement.

(6) Judge - a recorder scoring the results sheet and calling each athlete (and the one who is to follow).

(7) Judge in charge of the scoreboard (trial-number-result).

(8) Judge in charge of the clock indicating to the athletes that they have a certain time to take their trial.

(9) Judge in charge of athletes.

(10) Judge in charge of the implement stand.

Note (i): This is the traditional setting-up of the officials. In major competitions, where a data system and electronic scoreboards are available, specialised personnel are certainly required. To be clear in these cases, the progress and scoring of a Field Event is followed by both the recorder and by the data system.

Note (ii): Officials and equipment must be placed in such a way as not to obstruct the athlete’s way nor impede the view of the spectators.

Note (iii): A space must be reserved for a wind-sock to indicate the wind direction and strength.

SECTION V – COMBINED EVENTS COMPETITIONS

RULE 200 COMBINED EVENTS COMPETITIONS

U18 Boys, U20 and Senior Men (Pentathlon and Decathlon)

1. The Pentathlon consists of five events which shall be held on one day in the following order: Long Jump; Javelin Throw; 200m; Discus Throw; and 1500m.
2. The U18 Boys' and the Men's Decathlon consists of ten events which shall be held on two consecutive days in the following order:

First day: 100m; Long Jump; Shot Put; High Jump; 400m.
Second day: 110m Hurdles; Discus Throw; Pole Vault;
Javelin Throw; 1500m.

U20 and Senior Women (Heptathlon and Decathlon)

3. The Heptathlon consists of seven events, which shall be held on two consecutive days in the following order:

First day: 100m Hurdles; High Jump; Shot Put; 200m.
Second day: Long Jump; Javelin Throw; 800m.

4. The Women's Decathlon consists of ten events which shall be held on two consecutive days in the order of Rule 200.2 or in the following order:

First day: 100m; Discus Throw; Pole Vault; Javelin Throw;
400m.
Second day: 100m Hurdles; Long Jump; Shot Put;
High Jump; 1500m.

U18 Girls (Heptathlon only)

5. The U18 Girls' Heptathlon consists of seven events, which shall be held on two consecutive days in the following order:

First day: 100m Hurdles; High Jump; Shot Put;
200m.

Second day: Long Jump; Javelin Throw; 800m.

General

6. At the discretion of the Combined Events Referee, there shall, whenever possible, be an interval of at least 30 minutes between the time one event ends and the next event begins, for any individual athlete. If possible, the time between the finish of the last event on the first day and the start of the first event on the second day should be at least 10 hours.

The minimum period of 30 minutes is to be calculated as being the actual time between the end of the last race or trial for any athlete in the previous event to the start of the first race or trial in the next event. It is therefore possible and not uncommon for athletes to go directly from the conclusion of one event to the warm-up for the next so that the 30 minutes is in effect taken up by the movement from one site to another and the warm-up. Changes in the number of days over which a Combined Events competition is conducted are not allowed except for special cases (e.g. exceptional weather conditions). Such decisions are matters for the Technical Delegates and/or Referees in the particular circumstances of each case. However if, for any reason, the competition is held for a longer period than according to Rules 200 or 223 then a record in Combined Events (total number of points) cannot be ratified.

7. In each separate event, except the last, of a Combined Events competition, the heats and groups shall be arranged by the Technical Delegate(s) or Combined Events Referee, as applicable, so that the athletes with similar performances in each individual event during a predetermined period, shall be placed in the same heat or group. Preferably five or more, and never less than three, athletes shall be

placed in each heat or group. When this cannot be achieved because of the timetable of events, the heats or groups for the next event should be arranged as and when athletes become available from the previous event.

In the last event of a Combined Events competition, the heats should be arranged so that the last one contains the leading athletes after the penultimate event.

The Technical Delegate(s) or the Combined Events Referee shall have the authority to rearrange any group if, in his opinion, it is desirable.

8. The Rules for each event constituting the competition will apply with the following exceptions:
 - (a) in the Long Jump and each of the throwing events, each athlete shall be allowed three trials only.
 - (b) in case a Fully Automatic Timing and Photo Finish System is not available, each athlete's time shall be taken by three Timekeepers independently.
 - (c) in the Track Events, only one false start per race shall be allowed without the disqualification of the athlete(s) responsible for the false start. Any athlete(s) responsible for further false starts in the race shall be disqualified by the Starter (see also Rule 162.8).
 - (d) in the Vertical Jumps, each increase of the bar shall be uniform throughout the competition: 3cm in the High Jump and 10cm in the Pole Vault.
9. Only one system of timing may be applied throughout each individual event. However, for Record purposes, times obtained from a Fully Automatic Timing and Photo Finish system shall be applied regardless of whether such times are available for other athletes in the event.

Two systems of timekeeping are recognised for this purpose – those set out in Rule 165.1 (a) and (b).

If for example there is a malfunction of Photo Finish being used for some but not all of the heats it will be impossible to compare directly the points scores in the two systems for the same time - one by hand time and the other automatic.

Since under Rule 200.9, only one system of timing may be applied

throughout any single event in a competition, in such a case all athletes would have their points determined based on their manual times using the specific manual times table.

To be clear, if in other events all athletes have Photo Finish times, the electronic times table can be used for those events.

10. Any athlete failing to attempt to start or make a trial in one of the events shall not be allowed to take part in the subsequent events but shall be considered to have abandoned the competition. He shall not, therefore, figure in the final classification.
Any athlete deciding to withdraw from a Combined Events competition shall immediately inform the Combined Events Referee of his decision.
11. The scores, according to the current IAAF Combined Events Scoring Tables, shall be announced, separate for each event and as a cumulative total, to all athletes after the completion of each event. The athletes shall be placed in order according to the total number of points obtained.

The same Scoring Tables are used for each event even if for the younger age groups the specifications for the hurdles or throwing implements differ from those used for senior competition.

The score for any performance in either a Track Event or a Field Event can be found in the appropriate table. In many events, not all possible times or distances are listed in the table. In such cases, the score for the nearest lesser performance should be used.

Example: For the women's Javelin Throw there is no points score shown for a distance of 45.82m. The nearer shorter distance listed in the table is 45.78m for which there is a score of 779 points.

Ties

12. If two or more athletes achieve an equal number of points for any place in the competition, it shall be determined as a tie.

RULE 200 S 1 UKA SUPPLEMENT
COMBINED EVENTS FOR AGE GROUPS YOUNGER THAN
IAAF AGE GROUPS

(1) The Outdoor Pentathlon for Under 15 Boys consists of five events which may be held on one day or on two consecutive days in the following order: 80 metres Hurdles, Putting the Shot, Long Jump, High Jump, 800 metres.

(2) The Outdoor Pentathlon for Under 15 Girls consists of five events which should be held on one day or on two consecutive days in the following order: Long Jump, 75 metres Hurdles, Putting the Shot, (break of one hour), High Jump, 800 metres.

NOTE: If practicable, there should be at least a 30 minute break between events. If the Pentathlon is held on one day the competition should be split into two sessions with a break of one hour between each session.

(3) The Hexathlon for Under 15 Girls consists of six events which shall be held over two days; 75 metres Hurdles (which shall begin the first day), Long Jump, Throwing the Javelin, High Jump, Putting the Shot, 800 metres (which shall be the final event).

(4) The Outdoor Heptathlon for Under 17 Women shall be held on two consecutive days in the following order: first day: 80 metres Hurdles, High Jump, Putting the Shot, 200 metres. Second day: Long Jump, Throwing the Javelin, 800 metres but the Hurdle event specifications shall be those relating to this age group and the order of events shall be flexible.

(5) The Outdoor Octathlon for Under 17 Men shall consist of the following eight events held over two days: High Jump, Long Jump, Putting the Shot, Throwing the Discus, Throwing the Javelin, 100 metres Hurdles, 400 metres (which shall conclude the first day's programme) and 1500 metres (which shall be the final event).

(6) The Outdoor Octathlon for Under 15 Boys shall consist of the following eight events held over two days: 100 metres (which shall begin the first day), 80 metres Hurdles, High Jump, Pole Vault, Throwing the Discus, Throwing the Javelin, 400 metres (which shall conclude the first day's programme), and 1000 metres (which shall be the final event).

SECTION VI – INDOOR COMPETITIONS

RULE 210 APPLICABILITY OF OUTDOOR RULES TO INDOOR COMPETITIONS

With the exceptions stated in the following Rules of this Section VI and the requirement for wind measurement set out in Rules 163 and 184, the Rules of Sections I to V for outdoor competitions shall apply to Indoor Competitions.

RULE 211 THE INDOOR STADIUM

1. The stadium shall be completely enclosed and covered. Lighting, heating and ventilation shall be provided to give satisfactory conditions for competition.
2. The Field of Play should include an oval track; a straight track for sprints and hurdles; runways and landing areas for jumping events. In addition, a circle and landing sector for the Shot Put should be provided, whether permanently or temporarily. All the facilities should conform to the specifications in the IAAF Track and Field Facilities Manual.
3. All the tracks, runways or take-off surface areas shall be covered with a synthetic material that should preferably be able to accept 6mm spikes in running shoes.
Alternative thicknesses may be provided by the stadium management, who will notify athletes of the permissible length of spikes. (See Rule 143.4).
Indoor Track and Field competitions under Rules 1.1(a), (b), (c), and (f) should be held only on facilities that hold an IAAF Indoor Athletics Facility Certificate. It is recommended that, when such facilities are available, competitions under Rules 1.1(d), (e), (g), (h), (i) and (j) should also be held on these facilities.
4. The foundation on which the synthetic surface of the tracks, runways and take-off areas is laid shall be either solid e.g. concrete or, if of suspended construction (such as wooden boards or plywood sheets mounted on joists), without any special sprung sections and, as far as technically possible, each runway shall have a uniform resilience throughout. This shall be checked, for the take-off area for the jumps, before each competition.

Note (i): A "sprung section" is any deliberately engineered or constructed section designed to give extra assistance to an athlete.

Note (ii): The IAAF Track and Field Facilities Manual, which is available from the IAAF Office, or may be downloaded from the IAAF website, contains more detailed and defined specifications for planning and construction of indoor stadia including diagrams for track measurement and marking.

Note (iii): The current standard forms required to be used for the certification application and measurement report as well as the Certification System Procedures are available from the IAAF Office, or may be downloaded from the IAAF website.

Lack of suitable lighting is a common problem for Indoor Competitions. A covered stadium must have a lighting which allows a correct and fair delivery of the events and if there is television coverage the illumination level may need to be higher. The finish line area(s) may require additional lighting for the Fully Automatic Timing.

RULE 212 THE STRAIGHT TRACK

1. The lateral inclination of the track should not exceed 1:100 (1%) unless special circumstances exist which justify the IAAF providing an exemption, and the inclination in the running direction shall not exceed 1:250 (0.4%) at any point and 1:1000 (0.1%) overall.

Lanes

2. The track should have a minimum of 6 and a maximum of 8 lanes separated and bounded on both sides by white lines 50mm wide. The lanes shall all be $1.22\text{m} \pm 0.01\text{m}$ wide including the lane line on the right.

Note: For all tracks constructed before 1 January 2004, the lanes may have a width of maximum 1.25m. However, when such a track is fully resurfaced or replaced, the lane width shall comply with this Rule.

Start and Finish

3. There should be a clearance of at least 3m behind the start line free

of any obstruction. There shall be a clearance of at least 10m beyond the finish line free of any obstruction with adequate provision beyond for an athlete to come to a halt without injury.

Note: It is strongly recommended that the minimum clearance beyond the finish line should be 15m.

RULE 213 THE OVAL TRACK AND LANES

1. The nominal length should preferably be 200m. It shall consist of two parallel straights and two bends, which may be banked, whose radii should be equal.

The inside of the track shall be bordered either with a kerb of suitable material, approximately 50mm in height and width, or with a white line 50mm wide. The outside edge of this kerb or line forms the inside of lane 1. The inside edge of the kerb or line shall be horizontal throughout the length of the track with a maximum slope of 1:1000 (0.1%). The kerb on the two straights may be omitted, and a white line 50mm wide substituted.

Note: All measurements shall be taken as indicated in Rule 160.2.

Lanes

2. The track should have a minimum of four and a maximum of six lanes. The nominal width of the lanes shall be between 0.90m and 1.10m including the lane line on the right. All lanes shall be of the same nominal width with a tolerance of $\pm 0.01\text{m}$ to the selected width. The lanes shall be separated by white lines 50mm wide.

Banking

3. The angle of banking in all the lanes in the bend and, separately, in the straight, should be the same at any cross section of the track. The straight may be flat or have a maximum lateral inclination of 1:100 (1%) towards the inside lane.

In order to ease the change from the straight to the banked bend, the change may be made with a smooth gradual horizontal transition which may be extended into the straight. In addition, there should be a vertical transition.

Marking of the Inside Edge

4. Where the inside edge of the track is bordered with a white line, it

shall be marked additionally with cones or flags on the bends and, optionally, on the straights. The cones shall be at least 0.20m high. The flags shall be approximately 0.25m × 0.20m in size, at least 0.45m high and set at an angle of 60° with the ground away from the track. The cones or flags shall be placed on the white line so that the edge of the base of the cone or flag pole coincides with the edge of the white line closest to the track. The cones or flags shall be placed at intervals not exceeding 1.5m on the bends and 10m on the straights.

Note: For all indoor competitions directly under the IAAF, the use of an inside kerb is strongly recommended.

An oval track may be longer than 200m but any records for 200m or longer races would not be ratified. The development of a 200m track is therefore more advantageous than those of a shorter distance. To organise top level competitions, it will be useful to have a 6 lane track. The ideal width of the lanes of an oval track should be 1m.

Cones must be placed not only along the bends, but along the whole of the oval track.

When positioning the flags or cones it must be taken into account that the white line on the inside edge of lane 1 does not belong to the runner drawn in that lane. Cones are preferred and recommended for Indoor Competitions.

RULE 214 START AND FINISH ON THE OVAL TRACK

1. Technical information on the construction and marking of a 200m banked indoor track are given in detail in the IAAF Track and Field Facilities Manual. The basic principles to be adopted are given hereunder.

Basic Requirements

2. The start and finish of a race shall be denoted by white lines 50mm wide, at right angles to the lane lines for straight parts of the track and along a radius line for curved parts of the track.
3. The requirements for the finish line are that, if at all possible, there should be only one for all the different lengths of race, it shall be on a straight part of the track and as much of that straight as possible

should be before the finish.

4. The essential requirement for all start lines, straight, staggered or curved, is that the distance for every athlete, when taking the shortest permitted route, shall be the same.
5. As far as possible, start lines (and takeover zone lines for Relay Races) should not be on the steepest part of the banking.

Conduct of the Races

6. (a) Races of up to, and including, 300m shall be run entirely in lanes.

UKA Note: 300m races shall start and continue in lanes until the breakline marked at the end of the second bend.

- (b) Races over 300m, and less than 800m shall start and continue in lanes until the breakline marked at the end of the second bend.
- (c) For the start of races of 800m, each athlete may be assigned a separate lane, or up to two athletes may be assigned per lane, or a group start, as in Rule 163.5(b) preferably commencing in lanes 1 and 4, may be used. In these cases, athletes may leave their lane, or those running in the outer group may join the inner group, only after the breakline marked at the end of the first bend, or if the race is run with two bends in lanes, at the end of the second bend. A single curved start line may also be used.

UKA Note: A (single) arced start may be used for 800m races.

- (d) Races longer than 800m shall be run without lanes using an arced start line or group starts. If a group start is used, the breakline shall be at the end of either the first or second bend.

If an athlete does not follow this Rule, he shall be disqualified.

The breakline shall be an arced line marked after each bend, 50mm wide, across all lanes other than lane 1. To assist athletes identify the breakline, small cones, prisms or other suitable markers, 50mm × 50mm and no more than 0.15m high, preferably of different colour from the breakline and the lane lines, shall be placed on the lane lines immediately before the intersection of the lane lines and the breakline.

Note (i): In competitions other than those held under Rules 1.1(a), (b), (c) and (f), the participating teams may agree not to use lanes for the 800m event.

Note (ii): On tracks with less than six lanes, a group start may be used to allow six athletes to compete.

Start Line and Finish Line for a Track of 200m Nominal Length

7. The start line in lane 1 should be on the principal straight. Its position shall be determined so that the most advanced staggered start line in the outside lane (400m races) should be in a position where the angle of banking should not be more than 12 degrees.

The finish line for all races on the oval track shall be an extension of the start line in lane 1, right across the track and at right angles to the lane lines.

Colours to use for marking the track are indicated on the Track Marking Plan included in the IAAF Track and Field Facilities Manual.

RULE 215 DRAW FOR LANES IN TRACK EVENTS

1. For all events run wholly or partly in lanes around a bend, where there are successive rounds of a race, three draws for lanes will be made:
 - (a) one for the two highest ranked athletes or teams to determine placings in the outer two lanes;
 - (b) another for the third and fourth ranked athletes or teams to determine placings in the next two lanes;
 - (c) another for the other athletes or teams to determine placings in any remaining inner lanes.The ranking referred to shall be determined as follows:
 - (d) for the first round, from the relevant list of valid performances achieved during the predetermined period;
 - (e) after the first round, in accordance with the procedures identified in Rule 166.3(b)(i) or in the case of the 800m, in Rule 166.3(b)(ii).
2. For all other races, the lane order shall be drawn in accordance with Rules 166.4 and 166.5.

Where tracks have a different configuration of lanes, then the tables to be

used should be adapted either in the specific Technical Regulations for the competition or if not by the Technical Delegate(s) or the Organisers.

RULE 216 CLOTHING, SHOES AND ATHLETE BIBS

That part of each spike which projects from the sole or the heel shall not exceed 6mm (or as required by the Organisers) subject always to the maxima provided in Rule 143.4.

RULE 217 HURDLE RACES

1. The standard distances shall be: 50m or 60m on the straight track.
2. Layout of the hurdles for races:

	U18 Boys	U20 Men	Men	U18 Girls	U20 Women/Women
Height of hurdle	0.914m	0.991m	1.067m	0.762m	0.838m
Distance	50m/60m				
Number of hurdles	4/5				
Start line to first hurdle	13.72m			13.00m	
Between hurdles	9.14m			8.50m	
Last hurdle to finish line	8.86m/9.72m			11.50m/13.00m	

See Rule 168 S1 for UK Indoor Hurdles Specifications

RULE 218 RELAY RACES

Conduct of the Races

1. In the 4 × 200m race, all the first leg and the first bend of the second leg up to the nearer edge of the breakline described in Rule 214.6, shall be run in lanes. Each takeover zone shall be 20m long and the second, third and fourth athlete shall start within this zone.
2. The 4 × 400m race shall be run according to Rule 214.6(b).
3. The 4 × 800m race shall be run according to Rule 214.6(c).
4. The waiting athletes in the third and fourth legs of the 4 × 200m race, in the second, third and fourth legs of the 4 × 400m and the 4 × 800m race shall, under the direction of a designated official, place themselves in their waiting position in the same order (inside to out)

as the order of their respective team members as they enter the last bend. Once the incoming athletes have passed this point, the waiting athletes shall maintain their order, and shall not exchange positions at the beginning of the takeover zone. If an athlete does not follow this Rule, his team shall be disqualified.

Note: Owing to the narrow lanes, indoor Relay Races are much more liable to collisions and unintended obstruction than outdoor Relay Races. It is, therefore, recommended that, when possible, a spare lane should be left between each team.

RULE 219 HIGH JUMP

Runway and Take-Off Area

1. If portable mats are used, all references in the Rules to the level of the take-off area must be construed as referring to the level of the top surface of the mat.
2. An athlete may start his approach on the banking of the oval track provided that the last 15m of his run up is on a runway complying with Rules 182.3, 182.4 and 182.5.

RULE 220 POLE VAULT

Runway

An athlete may start his approach on the banking of the oval track provided that the last 40m of his run up is on a runway complying with Rules 183.6 and 183.7.

RULE 221 HORIZONTAL JUMPS

Runway

An athlete may start his approach on the banking of the oval track provided that the last 40m of his run up is on a runway complying with Rules 184.1 and 184.2.

RULE 222 SHOT PUT

Landing Sector

1. The landing sector shall consist of some suitable material on which the shot will make an imprint, but which will minimise any bounce.
2. Where necessary to ensure the safety of spectators, officials and

athletes, the landing sector shall be enclosed at the far end and on the two sides by a stop barrier and/or protective netting, placed as close to the circle as required. The recommended minimum height of the netting should be 4m and sufficient to stop a shot, whether in flight or bouncing from the landing surface.

3. In view of the limited space in an indoor Field of Play, the area enclosed by the stop barrier may not be large enough to include a full 34.92° sector. The following conditions shall apply to any such restriction.
 - (a) The stop barrier at the far end shall be at least 0.50m beyond the current World Record in Shot Put for men or women.
 - (b) The sector lines on either side shall be symmetrical about the centre line of the 34.92° sector.
 - (c) The sector lines may either run radially from the centre of the Shot Put circle including a full 34.92° sector, or may be parallel to each other and the centre line of the 34.92° sector. Where the sector lines are parallel, the minimum separation of the two sector lines shall be 9m.

It is recommended that the stop barrier / protective netting on either side should be extended towards the circle so that it starts within 8m of it and that, for the length of these extensions, the height of the netting should be at least 5m.

Construction of the Shot

4. Depending on the type of landing area (see Rule 222.1), the shot shall be either solid metal or metal cased or, alternatively, soft plastic or rubber casing with a suitable filling. Both types of shot may not be used in the same competition.

Solid Metal or Metal Cased Shot

5. These shall comply with Rule 188.4 and 188.5, for the Shot Put outdoors.

Plastic or Rubber Cased Shot

6. The shot shall have a soft plastic or rubber case with a suitable filling

such that no damage shall be caused when landing on a normal sports hall floor. It shall be spherical in shape and its surface finish shall be smooth.

Information for manufacturers: to be smooth, the surface average height must be less than $1.6\mu\text{m}$, i.e. a roughness number N7 or less.

7. The shot shall conform to the following specifications:

Minimum weight for admission to competition and acceptance of a Record:

3.000kg 4.000kg 5.000kg 6.000kg 7.260kg

Diameter:

Minimum 85mm 95mm 100mm 105mm 110mm

Maximum 120mm 130mm 135mm 140mm 145mm

RULE 223 COMBINED EVENTS COMPETITIONS

U18 Boys, U20 and Senior Men (Pentathlon)

1. The Pentathlon consists of five events, which shall be held on one day in the following order:

60m Hurdles; Long Jump; Shot Put; High Jump; 1000m.

U18 Boys, U20 and Senior Men (Heptathlon)

2. The Heptathlon consists of seven events which shall be held over two consecutive days in the following order:

First day: 60m; Long Jump; Shot Put; High Jump.

Second day: 60m Hurdles; Pole Vault; 1000m.

U18 Girls, U20 and Senior Women (Pentathlon)

3. The Pentathlon consists of five events and shall be held on one day in the following order:

60m Hurdles; High Jump; Shot Put; Long Jump; 800m.

Heats and Groups

4. Preferably four or more, and never less than three, athletes shall be placed in each heat or group.

SECTION VII – RACE WALKING EVENTS

RULE 230 RACE WALKING

Distances

1. The standard distances shall be: indoor: 3000m, 5000m; outdoor: 5000m, 10km, 10,000m, 20km, 20,000m, 50km, 50,000m.

Definition of Race Walking

2. Race Walking is a progression of steps so taken that the walker makes contact with the ground, so that no visible (to the human eye) loss of contact occurs. The advancing leg must be straightened (i.e. not bent at the knee) from the moment of first contact with the ground until the vertical upright position.

Judging

3. (a) The appointed Judges of Race Walking shall elect a Chief Judge, if one has not been appointed previously.
(b) All the Judges shall act in an individual capacity and their judgements shall be based on observations made by the human eye.
(c) In competitions held under Rule 1.1(a), all Judges shall be International Race Walking Judges. In competitions held under Rules 1.1(b), (c), (e), (f), (g) and (j), all Judges shall be either Area or International Race **Walking Judges**.
(d) For Road Races, there should normally be a minimum of six to a maximum of nine Judges including the Chief Judge.
(e) For Track Races, there should normally be six Judges including the Chief **Judge**.
(f) In competitions held under Rule 1.1(a) not more than one Judge (excluding the Chief Judge) affiliated with any one Member can officiate.

Note: The Member affiliation of each Judge is that properly stated on the current lists of Area and International Race Walking Judges.

RULE 230 S 1 UKA SUPPLEMENT

All walking races must be judged by judges holding a UKA officials' licence for Race Walk judging. The responsibility for ensuring that races are properly judged rests with the Competition Provider who, if unable to find the judges from within his/her own Club, should apply to the appropriate National Judges' Secretary for judges. Any application for judges must include details of the status of the race(s) so that judges of an appropriate grade can be provided. Applications should be made at least three months before the date of the race(s).

The system of judging set out in IAAF Rule 230.4-6 (IAAF system) must be used in all UKA Championships. Additionally this system should be adopted in other races with the following exceptions:

- when there are fewer than three judges in attendance,
- relays,
- point-to-point races.

The power of the Chief Judge to disqualify in the last 100m described in Rule 230 4(a) shall be applied to all UK, National and Regional championships.

Chief Judge

4. (a) In competitions held under Rules 1.1(a), (b), (c), (d) and (f), the Chief Judge has the power to disqualify an athlete in the last 100m, when his mode of progression obviously fails to comply with the Rule 230.2 regardless of the number of previous Red Cards the Chief Judge has received on that athlete. An athlete who is disqualified by the Chief Judge under these circumstances shall be allowed to finish the race. He shall be notified of this disqualification by the Chief Judge or a Chief Judge's Assistant by showing the athlete a red paddle at the earliest opportunity after the athlete has finished the race.
- (b) The Chief Judge shall act as the supervising official for the competition, and act as a Judge only in the special situation noted in Rule 230.4(a). In competitions held under Rules 1.1(a), (b), (c) and (f), two or more Chief Judge's Assistants shall be appointed. The Chief Judge's Assistant(s) are to assist with the

notification of disqualifications only and shall not act as Race Walking Judges.

- (c) For all competitions held under Rules 1.1(a), (b), (c) and (f) and where possible for other competitions, an official in charge of the Posting Board(s) and a Chief Judge's Recorder shall be appointed.

Yellow Paddle

5. When a judge is not completely satisfied that an athlete is fully complying with Rule 230.2, he should, where possible, show the athlete a yellow paddle with the symbol of the offence on each side. An athlete cannot be shown a second yellow paddle by the same Judge for the same offence. Having shown a yellow paddle to an athlete, the Judge shall inform the Chief Judge of his action after the competition.

Red Cards

6. When a Judge observes an athlete failing to comply with Rule 230.2 by exhibiting visible loss of contact or a bent knee during any part of the competition, the Judge shall send a Red Card to the Chief Judge.

Disqualification

7. (a) Except as provided in Rule 230.7(c), when three Red Cards from three different Judges have been sent to the Chief Judge on the same athlete, the athlete is disqualified and he shall be notified of this disqualification by the Chief Judge or a Chief Judge's Assistant by being shown a red paddle. The failure to give notification shall not result in the reinstatement of a disqualified athlete.
- (b) In competitions under Rules 1.1(a), (b), (c) or (e), in no circumstances shall the Red Cards of two Judges affiliated with the same Member have the power to disqualify.

Note: The Member affiliation of each Judge is that properly stated on the current lists of Area and International Race Walking Judges.

- (c) A Pit Lane shall be used for any race where the applicable regulations for the competition so provide and may be used for

other races as determined by the relevant governing body or Organisers. In such cases, an athlete will be required to enter the Pit Lane and remain there for the applicable period once they have received three Red Cards and are so advised by the Chief Judge or someone delegated by him.

The applicable period in the Pit Lane shall be as follows:

Races up to and including	Time
5000m/5km	0.5min
10,000m/10km	1min
20,000m/20km	2min
30,000m/30km	3min
40,000m/40km	4min
50,000m/50km	5min

If, at any time, the athlete receives an additional Red Card from a Judge other than one of the three who had previously sent a Red Card, he shall be disqualified. An athlete who fails to enter the Pit Lane when required to do so, or remain there for the applicable period, shall be disqualified by the Chief Judge.

- (d) In Track Races, an athlete who is disqualified shall immediately leave the track and, in Road Races, shall, immediately after being disqualified, remove the distinguishing bibs and leave the course. Any disqualified athlete who fails to leave the course or track or comply with directions given under Rule 230.7(c) to enter and remain for the required period in the Pit Lane may be liable to further disciplinary action in accordance with Rules 125.5 and 145.2.
- (e) One or more Posting Boards shall be placed on the course and near the finish to keep athletes informed about the number of Red Cards that have been sent to the Chief Judge for each athlete. The symbol of each offence should also be indicated on the Posting Board.
- (f) For all Rule 1.1(a) competitions, hand held computer devices with transmission capability must be used by the Judges to communicate all Red Cards to the Recorder and the Posting Board(s). In all other competitions, in which such a system is not used, the Chief Judge, immediately after the end of the event, shall report to the Referee the identification of all athletes disqualified under Rules 230.4(a), 230.7(a) or 230.7(c) by

indicating the bib identification, the time of the notification and the offences; the same shall be done for all the athletes who received Red Cards.

Start

8. The races shall be started by the firing of a gun. The commands for races longer than 400m shall be used (Rule 162.2(b)). In races which include a large number of athletes, five-minute, three-minute and one-minute warnings before the start of the race should be given. On the command "On your marks", the athletes shall assemble on the start line in the manner determined by the organisers. The Starter shall ensure that no athlete has his foot (or any part of his body) touching the start line or the ground in front of it, and shall then start the race.

Safety

9. The Organisers of Race Walking events shall ensure the safety of athletes and officials. In competitions held under Rules 1.1(a), (b), (c) and (f), the Organisers shall ensure that the roads used for the competition are closed to motorised traffic in all directions.

Drinking / Sponging and Refreshment Stations in Road Events

10. (a) Water and other suitable refreshments shall be available at the start and finish of all races.
- (b) For all events of 5km or longer up to and including 10km, water only drinking / sponging stations shall be provided at suitable intervals if weather conditions warrant such provision.

Note: Mist stations may also be arranged, when considered appropriate under certain organisational and/or climatic conditions.

- (c) For all events longer than 10km, refreshment stations shall be provided every lap. In addition, water only drinking / sponging stations shall be placed approximately midway between the refreshment stations or more frequently if weather conditions warrant such provision.
- (d) Refreshments, which may be provided by either the Organisers or the athlete, shall be placed at the stations so that they are easily accessible to, or may be put by authorised persons into

the hands of, the athletes. Refreshments provided by the athletes shall be kept under the supervision of officials designated by the Organisers from the moment that the refreshments are delivered by the athletes or their representatives. Those officials shall ensure that the refreshments are not altered or tampered with in any way.

- (e) Authorised persons may not enter the course nor obstruct any athlete. They may hand the refreshment to the athlete either from behind, or from a position no more than one metre to the side, but not in front, of the table.
- (f) In competitions held under Rules 1.1(a), (b), (c) and (f), a maximum of two officials per Member may be stationed at any one time behind the table. No official or authorised person shall, under any circumstances, move beside an athlete while he is taking refreshment or water.
Note: For an event in which a Member may be represented by more than three athletes, the Technical Regulations may allow additional officials at the refreshment tables.
- (g) An athlete may, at any time, carry water or refreshment by hand or attached to his body provided it was carried from the start or collected or received at an official station.
- (h) An athlete who receives or collects refreshment or water from a place other than the official stations, except where provided for medical reasons from or under the direction of race officials, or takes the refreshment of another athlete, should, for a first such offence, be warned by the Referee normally by showing a yellow card. For a second offence, the Referee shall disqualify the athlete, normally by showing a red card. The athlete shall then immediately leave the course.

Note: An athlete may receive from or pass to another athlete refreshment, water or sponges provided it was carried from the start or collected or received at an official station. However any continuous support from an athlete to one or more others in such a way may be regarded as unfair assistance and warnings and/or disqualifications as outlined above may be applied.

Generally, where it is logical and in accordance with practice, there is uniformity of the provisions within Rules 230, 240 and 250 pertaining to outside events. It should be noted however that Rule 230.10(e) above is intentionally different from Rule 240.8(e) in that in walking events, the team officials are not permitted in front of the tables.

Road Courses

11. (a) The circuit shall be no shorter than 1 km and no longer than 2km. For events that start and finish in the stadium, the circuit should be located as close as possible to the stadium.
- (b) Road courses shall be measured in accordance with Rule 240.3.

RULE 230 S 2 UKA SUPPLEMENT

Road Races may be promoted on open roads in the form of either a lap longer than 2km or a point-to-point race. In such cases Competition Providers must comply with all required safety conditions and conduct and work to appropriate risk assessments that comply with licensing conditions for events on the road.

Race Conduct

12. An athlete may leave the marked course with the permission and under the supervision of an official, provided that by going off course he does not shorten the distance to be covered.
13. If the Referee is satisfied on the report of a Judge or Umpire or otherwise that an athlete has left the marked course thereby shortening the distance to be covered, he shall be disqualified.

SECTION VIII – ROAD RACES

RULE 240 ROAD RACES

Distances

1. The standard distances shall be: 5km, 10km, 15km, 20km, Half-Marathon, 25km, 30km, Marathon (42.195km), 100km and Road Relay.

Note: It is recommended that the Road Relay race be run over the Marathon distance, ideally over a 5km loop course, with stages of 5km, 10km, 5km, 10km, 5km, 7.195km. For an U20 Road Relay, the recommended distance is a Half-Marathon with stages of 5km, 5km, 5km, 6.098km.

Course

2. The races shall be run on made-up roads. However, when traffic or similar circumstances make it unsuitable, the course, duly marked, may be on a bicycle path or footpath alongside the road, but not on soft ground such as grass verges or the like. The start and finish may be within an athletic Field of Play.

Note (i): It is recommended that, for Road Races staged over standard distances, the start and finish points, measured along a theoretical straight line between them should not be further apart than 50% of the race distance. For approval of Records, see Rule 260.21(b).

Note (ii): It is acceptable for the start, finish and other segments of the race to be conducted on grass or other non-paved surfaces. These segments shall be kept to a minimum.

3. The course shall be measured along the shortest possible route that an athlete could follow within the section of the road permitted for use in the race.

In all competitions under Rules 1.1(a) and, where possible, (b), (c) and (f), the measurement line should be marked along the course in a distinctive colour that cannot be mistaken for other markings.

The length of the course shall not be less than the official distance for the event. In competitions under Rules 1.1(a), (b), (c) and (f), the uncertainty in the measurement shall not exceed 0.1% (i.e. 42m for

the Marathon) and the length of the course should have been certified in advance by an IAAF approved course measurer.

Note (i): For measurement, the "Calibrated Bicycle Method" shall be used.

Note (ii): To prevent a course from being found to be short on future re-measurement, it is recommended that a "short course prevention factor" be built in when laying out the course. For bicycle measurements this factor should be 0.1% which means that each km on the course will have a "measured length" of 1001m.

Note (iii): If it is intended that parts of the course on race day will be defined by the use of non-permanent equipment such as cones, barricades, etc. their positioning shall be decided not later than the time of the measurement and the documentation of such decisions shall be included in the measurement report.

Note (iv): It is recommended that for Road Races staged over standard distances, the overall decrease in elevation between the start and finish should not exceed 1:1000, i.e. 1m per km (0.1%). For approval of Records, see Rule 260.21(c).

Note (v): A course measurement certificate is valid for 5 years, after which the course shall be re-measured even when there are no obvious changes to it.

UKA Note: A UK Course Measurement Certificate is valid for 10 years.

4. The distance in kilometres on the route shall be displayed to all athletes.
5. For Road Relays, lines 50mm wide shall be drawn across the course to mark the distances of each stage and to denote that scratch line. Similar lines shall be drawn 10m before and 10m after the scratch line to denote the takeover zone. All takeover procedures, which, unless otherwise specified by the organisers, shall comprise a physical contact between the incoming and outgoing athletes, shall be completed within this zone.

RULE 240 S 1 UKA SUPPLEMENT COURSE

- (1) The responsibility for providing a suitable course rests with the Competition Provider who must:
 - (i) take account of any advice given by the Local Authority Safety Advisory Group or equivalent, local Police Force, Highways Authority, Regional Licensing Panel and the UKA Course Measurer before publishing details of the course.
 - (ii) adequately signpost the course.
 - (iii) appoint marshals to direct runners throughout, particularly at intricate parts of the course and at road junctions.
- (2) Races shall be run on tarmac, concrete or paved surfaces. When traffic or similar circumstances make it unsuitable the course, duly marked, may be on a bicycle path or on a footpath, but should not be on soft ground such as verges or the like. Measuring a road surface can include a limited section off-road in length where needed. The agreed definition of a road course is determined from time to time by runbritain and the Association of UK Course Measurers.
- (3) A course that includes a railway level crossing will only be deemed safe and a licence issued where a written undertaking has been obtained from the Railway Track Authority that no train will use the line for the duration of the race.
- (4) The start and finish area may be in an enclosed ground or athletics arena. The start and finish areas should be traffic free.
- (5) If a race is advertised as being of a particular distance, then the correctness of that distance must be verified by a UKA qualified and registered and graded Course Measurer, accredited by, and using a measurement method approved by, the UK Association of Course Measurers.
 - (i) The course must be measured along the ideal line of running, i.e. the shortest possible route, in the section of the road permitted for runners, using a bicycle fitted with a Jones Counter and calibrated to IAAF standards.
 - (ii) The measured distance must not be less than the advertised distance of the race, nor should it exceed the advertised distance by more than 0.2%.
- (6) All runners must follow the course as designed and follow the

normal rules of the road except where otherwise instructed by representatives of the Local Police or Local Authority or other authorised persons.

- (7) Where any part of a road used for a race is open to traffic at the same time as the competition is in progress, a runner must remain on the left hand side of the road (unless directed otherwise by the Police or a race official or other authorised persons).
- (8) The Race Referee has the power to disqualify any runner who does not follow the correct course or obey the instructions of a race official after consultation with the Competition Provider.

Start

6. The races shall be started by the firing of a gun, cannon, air horn or like device. The commands for races longer than 400m shall be used (Rule 162.2(b)). In races which include a large number of athletes, five-minute, three-minute and one-minute warnings before the start of the race should be given. On the command “On your marks”, the athletes shall assemble on the start line in the manner determined by the organisers. The Starter shall ensure that no athlete has his foot (or any part of his body) touching the start line or the ground in front of it, and shall then start the race.

As for middle and long distance Track Events, it is emphasised for events held outside the stadium that Starters and Referees should avoid being over-zealous in the application of the false start Rules to such events. Recalling starts in road races and other outside events can be difficult, and in large fields impractical, in any case. However where there is a clear and wilful breach, the Referee should not hesitate to consider appropriate action in respect of an individual either during or after the race. However in major events, where the start mechanism malfunctions and it is clear or possible that the timing system may not have started a recall where practical might be the best option.

Safety

7. Organisers of Road Races shall ensure the safety of athletes and officials. In competitions held under Rules 1.1(a), (b), (c) and (f), the Organisers shall ensure that the roads used for the competition are closed to motorised traffic in all directions.

Drinking / Sponging and Refreshment Stations

8. (a) Water and other suitable refreshments shall be available at the start and finish of all races.
- (b) For all events, water shall be available at suitable intervals of approximately 5km. For events longer than 10km, refreshments other than water may be made available at these points.

Note (i): Where conditions warrant, taking into account the nature of the event, the weather conditions and the state of fitness of the majority of the competitors, water and/or refreshments may be placed at more regular intervals along the route.

Note (ii): Mist stations may also be arranged, when considered appropriate under certain organisational and/or climatic conditions.

- (c) Refreshments may include drinks, energy supplements, foodstuffs or any other item other than water. The Organisers will determine which refreshments it will provide based on prevailing conditions.
- (d) Refreshments will normally be provided by the Organisers but it may permit athletes to provide their own, in which case the athlete shall nominate at which stations they shall be made available to him. Refreshments provided by the athletes shall be kept under the supervision of officials designated by the Organisers from the time that the refreshments are lodged by the athletes or their representatives. Those officials shall ensure that the refreshments are not altered or tampered with in any way.
- (e) The Organisers shall delineate, by barriers, tables or markings on the ground, the area from which refreshments can be received or collected. It should not be directly in the line of the measured route. Refreshments shall be placed so that they are easily accessible to, or may be put by authorised persons into the hands of, the athletes. Such persons shall remain inside the designated area and not enter the course nor obstruct any athlete. No official or authorised person shall, under any circumstances, move beside an athlete while he is taking refreshment or water.

- (f) In competitions held under Rules 1.1(a), (b), (c) and (f), a maximum of two officials per Member may be stationed at any one time behind the area designated for them.

Note: For an event in which a Member may be represented by more than three athletes, the Technical Regulations may allow additional officials at the refreshment tables.

- (g) An athlete may, at any time, carry water or refreshment by hand or attached to his body provided it was carried from the start or collected or received at an official station.
- (h) An athlete who receives or collects refreshment or water from a place other than the official stations, except where provided for medical reasons from or under the direction of race officials, or takes the refreshment of another athlete, should, for a first such offence, be warned by the Referee normally by showing a yellow card. For a second offence, the Referee shall disqualify the athlete, normally by showing a red card. The athlete shall then immediately leave the course.

Note: An athlete may receive from or pass to another athlete refreshment, water or sponges provided it was carried from the start or collected or received at an official station.

However any continuous support from an athlete to one or more others in such a way may be regarded as unfair assistance and warnings and/or disqualifications as outlined above may be applied.

RULE 240 S 2 UKA SUPPLEMENT REFRESHMENTS

- (1) In full Marathons and longer races, Competition Providers must supply drinks to cater for the entire field at least every 5km throughout the race.
- (2) In races of 10km and above Competition Providers must supply drinks at intervals of not greater than 5km.
- (3) In races of less than 10km, drinks may be provided by the Competition Provider.
- (4) A Competition Provider must provide additional drink stations on the advice of the Race Medical Officer.

- (5) A Competition Provider should provide drinks for the entire field at the finish.

Race Conduct

9. An athlete may leave the marked course with the permission and under the supervision of an official, provided that by going off course he does not shorten the distance to be covered.
10. If the Referee is satisfied on the report of a Judge or Umpire or otherwise that an athlete has left the marked course thereby shortening the distance to be covered, he shall be disqualified.
11. Umpires should be placed at regular intervals and at each key point. Other umpires should move along the course during the race.

It is acknowledged that following the practice of first giving a warning when applying relevant aspects of Rule 240 and where applicable Rule 144.2 and 144.3 will create difficulties in implementation but where the opportunity arises, the Referee should do so. It is suggested that one option might be that course or refreshment station umpires be designated as assistant Referees and that they be in communication with the Referee and each other to ensure the effective co-ordination of warnings and disqualifications. But there remains the possibility as per the Note to Rule 144.2 that in some circumstances disqualification can, and should, occur without a warning being given.

When a Transponder Timing System is not in use, or where an additional back-up recording system is desired, it is recommended that a funnel system such as that described for Cross-Country Races in the commentary on Rule 250 be used.

RULE 240 S 3 UKA SUPPLEMENT RACE CLASSIFICATION

- (1) An open road race is one which is open to all eligible runners subject to the restrictions on age and distance as defined in Rule 141.
- (2) A closed road race is one open only to runners in a particular Service, occupation, business house or educational establishment.
- (3) An open team road race is open to all Clubs affiliated to a National Association. Athletes must be registered in the current year with

their National Association in order to compete as a First Claim athlete in Open Team Competition.

- (4) A closed team road race is confined to Clubs affiliated to UKA or other recognised Governing Body of athletics, within a particular category, e.g. Services, trade, occupation, business house, educational establishment.

NOTE: Team races may be included by Competition Providers within any race subject to the above classifications.

- (5) Competition Providers must declare in advance which team awards are included within the race and the manner in which they will be decided. Unless different details for a team competition are given by the Competition Providers any league competition held will be an open club team competition held with eligibility on the basis of (3) above.
- (6) Events for Masters shall be confined to athletes who are at least 35 years of age on the day of competition.

RULE 240 S 4 UKA SUPPLEMENT RELAYS

Where the number of stages in the relay exceeds eight, the number of entries will be restricted to three times the number of runners entitled to compete per team, or 36, whichever is the greater.

NOTE: IAAF Rule 240.1 relating to Relays will not apply.

RULE 240 S 5 UKA SUPPLEMENT HEADPHONES

The wearing of headphones, or similar devices, (other than those medically prescribed), is not permitted in races on any single carriageway road that is not wholly closed to traffic. This restriction does not apply to races held on dual carriageways provided that there are clear, structured separations between the separate carriageways. Competition Providers of races held entirely on roads closed to traffic may apply this condition where appropriate to local circumstances.

RULE 240 S 6 UKA SUPPLEMENT- ASSISTANCE

Runners must not be accompanied by a personally owned or controlled dog in the race.

|| *NOTE: Entries may be accepted from runners with medical assistance dogs, subject to them being correctly registered and identifiable as such; and subject to approval by the Race Director.*

SECTION IX – CROSS-COUNTRY, MOUNTAIN AND TRAIL RACES

There are extreme variations in conditions in which Cross-Country Running, Mountain Running and Trail Running are practised throughout the world and it is difficult to legislate international standardisation of these events. It must be accepted that the difference between very successful and unsuccessful events often lies in the natural characteristics of the venue and the abilities of the course designer. The following Rules are intended as a guide and incentive to assist Members to develop Cross-Country Running, Mountain Running and Trail Running.

RULE 250 CROSS-COUNTRY RACES

Distances

1. Distances at IAAF World Cross-Country Championships should be approximately:

Men	10km	Women	10km
U20 Men	8km	U20 Women	6km

The distances recommended for U18 competitions should be approximately:

U18 Boys	6km	U18 Girls	4km
----------	-----	-----------	-----

It is recommended that similar distances be used for other International and National competitions.

Course

2. (a) The course must be designed on an open or woodland area, covered as far as possible by grass, with natural obstacles, which can be used by the course designer to build a challenging and interesting race course.
(b) The area must be wide enough to accommodate not only the course but also all the necessary facilities.
3. For Championships and international events and, wherever possible, for other competitions:
 - (a) A loop course must be designed, with the loop measuring

between 1500m and 2000m. If necessary, a small loop can be added in order to adjust the distances to the required overall distances of the various events, in which case the small loop must be run in the early stages of the event. It is recommended that each long loop should have a total ascent of at least 10m.

- (b) Existing natural obstacles shall be used if possible. However, very high obstacles should be avoided, as should deep ditches, dangerous ascents / descents, thick undergrowth and, in general, any obstacle which would constitute a difficulty beyond the aim of the competition. It is preferable that artificial obstacles should not be used but if such use is unavoidable, they should be made to simulate natural obstacles met within open country. In races where there are large numbers of athletes, narrow gaps or other hindrances which would deny the athletes an unhampered run shall be avoided for the first 1500m.
 - (c) The crossing of roads or any kind of macadamised surfaces shall be avoided or at least kept to a minimum. When it is impossible to avoid such conditions in one or two areas of the course, the areas must be covered by grass, earth or mats.
 - (d) Apart from the start and finish areas, the course must not contain any other long straight. A "natural", undulating course with smooth curves and short straights, is the most suitable.
4. (a) The course shall be clearly marked with tape on both sides. It is recommended that all along one side of the course a 1m wide corridor, heavily fenced from the outside of the course, shall be installed for the use of organisation officials and media only (obligatory for Championship events). Crucial areas must be heavily fenced; in particular the start area (including the Warm-up Area and the Call Room) and finish area (including any mixed zone). Only accredited people will be allowed access to these areas.
- (b) The general public should only be allowed to cross the course in the early stages of a race at well organised cross-over points, marshalled by stewards.
 - (c) It is recommended that, apart from the start and finish areas, the course be a width of 5 metres, including the obstacle areas.

|| 5. For Cross-Country Relays, lines 50mm wide 20m apart shall be

drawn across the course to denote the takeover zone. All takeover procedures, which, unless otherwise specified by the organisers, shall comprise a physical contact between the incoming and outgoing athletes, shall be completed within this zone.

Start

6. The races shall be started by the firing of a gun. The commands for races longer than 400m shall be used (Rule 162.2(b)).

In races which include a large number of athletes, five-minute, three-minute and one-minute warnings should be given.

Departure boxes shall be provided for teams races and the members of each team shall be lined up behind each other at the start of the race. In other races, the athletes shall be lined up in the manner determined by the organisers. On the command “On your marks”, the starter shall ensure that no athlete has his foot (or any part of his body) touching the start line or the ground in front of it, and shall then start the race.

RULE 250 S 1 UKA SUPPLEMENT START

The start should be signalled by the firing of a gun or other similar apparatus. An athlete crossing the starting line before the starting signal is given shall be liable to disqualification.

Safety

7. Organisers of Cross-Country Races shall ensure the safety of athletes and officials.

Drinking / Sponging and Refreshment Stations

8. Water and other suitable refreshments shall be available at the start and finish of all races. For all events, a drinking / sponging station shall be provided every lap, if weather conditions warrant such provision.

Note: Where conditions warrant, taking into account the nature of the event, the weather conditions and the state of fitness of the majority of the competitors, water and sponges may be placed at more regular intervals along the route.

Race Conduct

9. If the Referee is satisfied on the report of a Judge or Umpire or otherwise that an athlete has left the marked course thereby shortening the distance to be covered, he shall be disqualified.

RULE 250 S 2 UKA SUPPLEMENT MISCELLANEOUS

- (1) No athlete who is not qualified to compete shall join a cross country race. Athletes infringing this rule shall be liable to expulsion from any race under the jurisdiction of UKA and could render their club liable to disqualification.
- (2) Open cross country races must be advertised and decided under these Rules. Appropriate entry forms must be used for all individual entries. Inter-Club races for which no entry fee is charged are not considered Open Events.
- (3) The wearing of headphones, or similar devices, (other than those medically prescribed), is not permitted in Cross Country races. Athletes infringing this rule shall be liable to disqualification.

The finish area shall be wide enough to enable several runners to sprint side by side and long enough to separate them at the finish.

Unless a Transponder Timing System is being used together with a backup system (such as a video recording) to check finishing orders, finish lanes ("funnels") should be set up some 8 to 10 metres after the finish line with a maximum width of 0.70-0.80m. Once in the funnels, the athletes must not be able to overtake one another. The funnels should be 35-40m long into which the athletes will be directed as they cross the finish line. At the end of each funnel, officials will note the athletes' numbers/names and if applicable recover their transponder timing chips. The funnels should have moveable ropes at the end at which the athletes enter, so that when one lane is full, the next rope can be drawn across behind the last athlete, to enable the next finisher to enter the new finish lane, and so on.

Judges and Timekeepers will additionally be placed on either side of the finish line and it is recommended that, in order to follow up any appeal relative to the finishing order, an official with video recording equipment

(if possible with a timing clock in sight) shall be assigned and placed a few metres after the finish line in order to record the order in which the athletes cross the line.

RULE 251 MOUNTAIN RACES

Types of Mountain Races

1. (a) Most Mountain Running races are mass starts in which all athletes start together or are started separately by sex or age categories.
- (b) For Mountain Running Relays, the composition, course distances and course types could vary widely, depending on the natural conditions and the plans of the Organisers.
- (c) Mountain Races with individual start times at various intervals are considered time trials. The results are ordered by the individual finish times.

Course

2. (a) Mountain Running takes place on terrain that is mainly off-road, unless there is significant elevation gain on the route in which case a macadamised surface is acceptable.
- (b) Each Mountain Running course is a specific one with the natural conditions dictating the basic course route. Existing roads and trails should preferably be used. The Organisers are responsible to care for the environment.
- (c) The course length may vary from 1km to the marathon distance respecting required technical details.
- (d) Courses can be mostly uphill, up and down or a mix.
- (e) The average incline should include a minimum of 5% (or 50m per km) and not exceed 20% (or 200m per km). The most preferable average elevation gain is approximately 100m per km provided that the course remains runnable.
- (f) Courses should be well marked. A detailed course map with a profile should be provided.

Start

3. The commands for races longer than 400m shall be used (Rule 162.2(b)).
In races which include a large number of athletes, five-minute, three-

minute and one-minute warnings before the start of the race should be given.

Safety

4. Organisers of Mountain Races shall ensure the safety of athletes and officials. Specific conditions such as high altitude in relation to the weather conditions and available infrastructure should be respected.

Drinking / Sponging and Refreshment Stations

5. Water and other suitable refreshments shall be available at the start and finish of all races. Additional drinking / sponging stations should be provided at suitable places along the course.

Race Conduct

6. If the Referee is satisfied on the report of a Judge or Umpire or otherwise that an athlete has left the marked course thereby shortening the distance to be covered, he shall be disqualified.

RULE 251 S 1 UKA SUPPLEMENT FELL AND HILL RACE CATEGORIES

(1) Domestic Race Categories

A fell race is one run on fell, hill or mountain terrain and shall be categorised as follows:

Category A

- (i) Should average not less than 50m of climb per km.
- (ii) Should not have more than 20% of the race distance on road.
- (iii) Should be at least 1.5km in length.

Category B

- (i) Should average not less than 25m of climb per km.
- (ii) Should not have more than 30% of the race distance on road.

Category C

- (i) Should average not less than 20m of climb per km.
- (ii) Should not have more than 40% of the distance on road.
- (iii) Should contain some genuine fell terrain.

(2) International Races

International races affiliated to the World Mountain Running Association, and selection races organised by National Associations for International Races.

(3) Race Length Categories

- (i) A Category ‘‘L’’ (long) race is 20km or over.
- (ii) A Category ‘‘M’’ (medium) race is over 10km but less than 20km.
- (iii) A Category ‘‘S’’ (short) race is 10km or less.

Official UKA Fell, Hill and Mountain Races must be organised to comply with the Safety Requirements.

Safety

- (4) The National Committees for Fell, Hill and Mountain Running are empowered to determine the rules and requirements for Fell, Hill and Mountain Running, including the Safety Rules for Competition Providers and runners, in consultation with UKA.

Veteran age limits in races (Men and Women)

- (5) For Fell, Hill and Mountain Running a Veteran is a competitor aged at least 40 years on the date of the competition.

RULE 252 TRAIL RACES

Course

1. (a) Trail Races take place on a variety of terrain (including dirt roads, forest paths and single track footpaths) within a natural environment in open country (such as mountains, desert, forests or plains) that is mainly off-road.
- (b) Sections of macadamised surfaces or concrete are acceptable but should be the minimum possible for the desired course and must not exceed 20% of the total distance of the race. There shall be no set limit on distance or altitude gain or loss.
- (c) The Organisers shall, prior to the race, announce the distance and total ascent / descent of the course which must have been measured and provide a map and detailed profile of the course together with a description of the technical difficulties to be confronted during the race.

- (d) The course must be marked in such a way that athletes receive sufficient information to complete it without deviating from it.

Equipment

2. (a) Trail Running does not specify the use of a particular technique or specific equipment in its progression.
- (b) The Organiser may, however, impose or recommend obligatory security equipment applicable to the conditions expected or possibly to be encountered during the race which would allow the athlete to avoid a situation of distress or, in the case of an accident, to give the alert and wait in safety for the arrival of help.
- (c) A survival blanket, whistle, supply of water and a food reserve are the minimum elements which each athlete should possess.
- (d) If specifically permitted by the Organisers, athletes may use poles such as hiking poles.

Start

3. The races shall be started by the firing of a gun. The commands for races longer than 400m shall be used (Rule 162.2(b)). In races which include a large number of athletes, five-minute, three-minute and one-minute warnings before the start of the race should be given.

Safety

4. The Organisers shall ensure the safety of athletes and officials and must have a race specific plan for health, safety and rescue, including the means to provide assistance to athletes and other participants in distress.

Aid Stations

5. Since Trail Running is based on self-sufficiency, each athlete shall be autonomous between aid stations in relation to clothing, communications, food and drink. Accordingly, aid stations shall be sufficiently spaced out according to the organisers' plan so as to respect the autonomy of athletes but taking in account health and safety.

Race Conduct

6. If the Referee is satisfied on the report of a Judge or Umpire or otherwise that an athlete has left the marked course thereby

shortening the distance to be covered, he shall be disqualified.

7. Assistance may only be provided at aid stations.
8. The Organisers of each trail race shall publish specific regulations setting out the circumstances that may result in the penalisation or disqualification of an athlete.

RULE 252 S 1 UKA SUPPLEMENT RACE CONDITIONS

- (1) **Support Stations:** Unless stated otherwise in the advertisement and competitors' brief, refreshment stations with drinks as a minimum requirement should be not less than 10km apart and stocked with sufficient for the whole field. In warm weather extra stations with separation as little as 5km may be necessary.
- (2) **Along Roads:** UK Athletics Rules for Road Running shall apply for parts of a course that are on roads, e.g. competitors must run on the left side of the road.

RULE 252 S 2 UKA SUPPLEMENT COMPETITORS' RESPONSIBILITIES

- (1) **Safety:** Competitors have a primary responsibility for their own safety.
- (2) **Course:** Follow the whole of the course as designed, unless they are leaving it for the purpose of retirement, in which event they may proceed to the nearest control station by a practically convenient route without trespassing. If they get lost or take a wrong turning competitors must return to the correct course, without trespassing, where they left it. They may be assisted in regaining the correct course.
- (3) **Other Rights of Way Users:** Unless the appropriate authority has closed the route to all other users, recognise they have equal rights to be on the path and be courteous.
- (4) **Behaviour at Obstacles & Narrow Paths:** Competitors should not jostle at stiles and other obstacles. Nor should they push past slower runners on narrow paths. The correct etiquette is for the overtaking runner to shout 'track' and the slower to step out of the way as soon

- as practical, standing still if necessary.
- (5) **Countryside Code:** In England and Wales 'The Countryside Code' must be obeyed, and in Scotland, The Scottish Access Code.
 - (6) **Injured Competitors:** If they come across another competitor who is ill or hurt they MUST offer assistance.
 - (7) **Voluntary Retirement:** If they wish to retire from the race they must report this to the nearest race official and to the finish, and then remove their number. If they become physically incapable of personally reporting, they should endeavour to get a message passed to an official.
 - (8) **Compulsory Retirement:** Retire immediately if asked to do so by a race official.

RULE 252 S 3 UKA SUPPLEMENT ASSISTANCE

- (1) **Assistance Whilst Running:** A competitor may only be accompanied by an attendant for all or part of a race when the rules for that particular race authorise this. Any limitations, such as when and where along the course this is allowed, must be clear in the rules of the race. Failure to comply may lead to disqualification of the competitor being helped.
- (2) **Supporters' Cars:** When the competitors' brief states that handlers and supporters following the race may park their cars only at designated places, failure to comply may lead to the disqualification of the competitor being supported.

SECTION X – WORLD RECORDS

RULE 260 WORLD RECORDS

Submission and Ratification

1. A World Record shall be made in a bona fide competition which has been duly arranged, advertised and authorised before the day of the event by the Member in whose Country or Territory the event takes place and which has been conducted under and in compliance with the Rules. For individual events, at least three athletes and for relay events, at least two teams must be bona fide competitors in the event. Except for Field Events conducted as provided in Rule 147 and competitions held outside the stadium under Rules 230 and 240, no performance set by an athlete will be ratified if it has been accomplished during a mixed competition.

Note: Women only Road Race records are subject to the conditions set out in Rule 261.

2. The following categories of World Records are accepted by the IAAF:
 - (a) World Records;
 - (b) World U20 Records;
 - (c) World Indoor Records;
 - (d) World U20 Indoor Records.

Note (i): For the purposes of these Rules, unless the context dictates otherwise, World Records refers to all categories of records under this Rule.

Note (ii): World Records under Rule 260.2(a) and (b) shall recognise the best ratified performances achieved at any facility complying with Rule 260.12 or 260.13.

3. An athlete (or athletes in the case of a relay event) who sets a World Record must:
 - (a) have been eligible to compete under the Rules;
 - (b) have been under the jurisdiction of a Member;
 - (c) in the case of a performance submitted under Rule 260.2(b) or (d), unless the athlete's date of birth has been previously confirmed by IAAF, must have his date of birth confirmed by his passport, birth certificate or similar official documentation,

a copy of which, if not available to be attached to the application form, must be provided by the athlete or athletes' National Federation to the IAAF without delay;

- (d) in the case of relay events, must all be eligible to represent a single Member in accordance with Rule 5.1.
- (e) submit to doping control at the end of the event, to be conducted in accordance with the Rules and IAAF Anti-Doping Regulations currently in force. The sample(s) collected shall be sent for analysis to a WADA-accredited laboratory and the result(s) sent to the IAAF to be added to the other information required by the IAAF for ratification. If such testing results in a doping violation, or if such a testing is not conducted, the performance will not be ratified.

Note (i): In the case of a Relay World Record, all members of the team must be tested;

Note (ii): If an athlete has admitted that, at some time prior to achieving a World Record, he had used or taken advantage of a substance or technique prohibited at that time, then, subject to the advice of the Athletics Integrity Unit, such record will not continue to be regarded as a World Record by the IAAF.

- 4. When a performance equals or betters an existing World Record, the Member of the Country where the performance was set shall collect together, without delay, all the information required for ratification of the Record by the IAAF. No performance shall be regarded as a World Record until it has been ratified by the IAAF. The Member should immediately inform the IAAF of its intention to submit the performance.
- 5. The submitted performance shall be better than or equal to the existing World Record for that event, as accepted by the IAAF. If a World Record is equalled it shall have the same status as the existing World Record.
- 6. The official application form of the IAAF shall be completed and dispatched to the IAAF Office within 30 days. If the application concerns a foreign athlete (or a foreign team), a duplicate of the form shall be sent within the same period to the Member of the athlete (or team).

Note: Forms are available, on request, from the IAAF Office, or may be downloaded from the IAAF website.

7. The Member of the Country where the performance was set shall send, with the official application form:
 - (a) The printed programme of the competition (or electronic equivalent);
 - (b) The complete results of the event, including all information required under this Rule;
 - (c) In the case of a Track World Record where Fully Automatic Timing was in operation, the photo finish and zero control test images;
 - (d) Any other information required to be submitted by this Rule, where such information is or should be in its possession.
8. Performances made in Qualification Rounds, in deciding ties in High Jump and Pole Vault, in any event or part of an event which is subsequently decreed void under the provisions of Rules 125.7 or 146.4(b), or in individual events in Combined Events competitions, regardless of whether or not the athlete completes the whole Combined Events competition, may be submitted for ratification.
9. The President and the Chief Executive Officer of the IAAF together are authorised to ratify World Records. If they are in any doubt whether or not the performance should be ratified, the case shall be referred to the Council for decision.
10. When a World Record has been ratified, the IAAF will:
 - (a) so inform the athlete's Member, the Member applying for the World Record and the relevant Area Association;
 - (b) supply the official World Record Plaques, for presentation to World Record holders.
 - (c) update the official List of World Records each time a new World Record has been ratified. This list shall represent the performances regarded by the IAAF as being, from the date of the list, the best ratified performances yet set by an athlete or team of athletes in each of the recognised events listed in Rules 261, 262, 263 and 264.
 - (d) formally publish (by Circular letter to Members) the status of this list as at 1 January of each year.
11. If the performance is not ratified, the IAAF will give the reasons.

Specific Conditions

12. Except in Road Events:

- (a) The performance shall be made in an IAAF certified athletics facility or at a competition area which conforms to Rule 140 or, where applicable, Rule 149.2.
- (b) For any performance at any distance of 200m or more to be ratified, the track on which it was made shall not exceed 402.3m (440 yards) and the race shall have started on some part of the perimeter. This limitation does not apply to the Steeplechase events where the Water Jump is placed outside a normal 400m track.
- (c) A performance in an oval Track Event shall be made in a lane where the running line radius does not exceed 50m, except where the bend is formed with two different radii, in which case the longer of the two arcs should not account for more than 60° of the 180° turn.
- (d) A performance made in a Track Event outdoors may be made only on a track which conforms to Rule 160.

13. For World Indoor Records:

- (a) The performance shall have been made in an IAAF certified athletics facility or at a competition area, which complies with Rule 211 to 213 as applicable.
- (b) For races of 200m and over, the oval track may not have a nominal length of more than 201.2m (220 yards).
- (c) The performance may be made on an oval track with a nominal length less than 200m provided that the distance run is within permitted tolerance for the distance.
- (d) The performance in an oval track event shall be made in a lane where the projected running line radius on the constant banked bend segment does not exceed 27m and for multiple lap events the two straights each are at least 30m long.
- (e) Any straight track shall comply with Rule 212.

14. For World Records in Running and Race Walking Events:

- (a) The performance shall be timed by official Timekeepers, by a Fully Automatic Timing and Photo Finish System (for which a zero control test has been undertaken in accordance with Rule 165.19) or by a Transponder System (see Rule 165.24) complying with IAAF Rules.

- (b) For races up to and including 800m (including 4 × 200m and 4 × 400m), only performances timed by a Fully Automatic Timing and Photo Finish System complying with IAAF Rules shall be ratified.
 - (c) For performances made outdoors up to and including 200m, information concerning wind velocity, measured as indicated in Rules 163.8 to 163.13 inclusive, shall be submitted. If the wind velocity, measured in the direction of running, averages more than 2 metres per second, the performance will not be ratified.
 - (d) No performance will be ratified where the athlete has infringed Rule 163.3 nor in the case an individual event where an athlete has recorded a false start as allowed under Rule 200.8(c).
 - (e) For performances up to and including 400m (including 4 × 200m and 4 × 400m) under Rules 261 and 263, starting blocks linked to an IAAF certified Start Information System under Rule 161.2 must have been used and have functioned correctly so that reaction times were obtained and are shown on the results of the event.
15. **For World Records set over multiple distances in the same race:**
- (a) A race shall be stated to be over one distance only.
 - (b) A race based on the distance covered over a given time may be combined with a race over a fixed distance (for example, 1 Hour and 20,000m - see Rule 164.3).
 - (c) It is permissible for the same athlete to submit multiple performances for ratification in the same race.
 - (d) It is permissible for several athletes to submit performances for ratification in the same race.
 - (e) A performance will not be ratified at a shorter distance if the athlete did not finish the full distance of that race.
16. **For World Records in Relay Events:**
The time set by the first athlete in a relay team may not be submitted for ratification as a World Record.
17. **For World Records in Field Events:**
- (a) The performances shall be measured either by three Field Judges using a calibrated and verified steel tape or bar or by a scientific measuring apparatus, the accuracy of which has been confirmed in accordance with Rule 148.
 - (b) In the Long Jump and Triple Jump conducted outdoors,

information concerning wind velocity, measured as indicated in Rules 184.10-12 shall be submitted. If the wind velocity, measured in the direction of jumping, averages more than 2 metres per second, the performance will not be ratified.

- (c) World Records may be credited for more than one performance in a competition, provided that each World Record so ratified shall have been equal or superior to the best previous performance at that moment.
- (d) In Throwing Events, the implement used shall have been checked prior to the competition in accordance with Rule 123. If the Referee becomes aware during an event that a World Record has been equalled or bettered, he shall immediately mark the implement used and undertake a check to ascertain whether it still complies with the Rules or if there has been any change in characteristics. Normally, such implement shall be checked again after the event in accordance with Rule 123.

|| 18. **For World Records in Combined Events:**

The conditions as set out in Rule 200.8 shall have been complied with in each of the individual events. In addition, for those events where wind velocity is required to be measured, the average velocity (based on the algebraic sum of the wind velocities, as measured for each individual event, divided by the number of such events) shall not exceed plus 2 metres per second.

19. **For World Records in Race Walking Events:**

At least three Judges who are either IAAF Level or Area Level International Race Walking Judges shall be officiating during the competition and shall sign the application form.

20. **For World Records in Road Race Walking Events:**

- (a) The course must be measured by an "A" or "B" grade IAAF/AIMS approved measurer who shall ensure that the relevant measurement report and any other information required by this Rule is available to the IAAF upon request.
- (b) The circuit shall be no shorter than 1km and no longer than 2km with a possible start and finish in a stadium.
- (c) Any course measurer who originally measured the course or other suitably qualified official designated by the measurer (after consulting the relevant body) with a copy of the documentation detailing the officially measured course must

validate that the course covered by the athletes conforms to the course measured and documented by the official course measurer.

- (d) The course must be verified (i.e. re-measured) as late as possible before the race, on the day of the race or as soon as practical after the race, by a different "A" grade measurer from any of those who did the original measurement.

Note: If the course was originally measured by at least two "A" or one "A" and one "B" grade measurers, no verification (re-measurement) under this Rule 260.20(d) will be required.

- (e) World Records in Road Race Walking Events set at intermediate distances within a race must comply with the conditions set under Rule 260. The intermediate distances must have been measured, recorded and subsequently marked as part of the course measurement and must have been verified in accordance with Rule 260.20(d).

21. For World Records in Road Running Events:

- (a) The course must be measured by an "A" or "B" grade IAAF/AIMS approved measurer who shall ensure that the relevant measurement report and any other information required by this Rule is available to the IAAF upon request.
- (b) The start and finish points of a course, measured along a theoretical straight line between them, shall not be further apart than 50% of the race distance.
- (c) The overall decrease in elevation between the start and finish shall not exceed 1:1000, i.e. 1m per km (0.1%).
- (d) Any course measurer who originally measured the course or other suitably qualified official designated by the measurer (after consulting the relevant body) with a copy of the documentation detailing the officially measured course shall in advance of the race check that the course is laid out in conformity with the course measured and documented by the official course measurer. He shall then ride in the lead vehicle during the competition or otherwise validate that the same course is run by the athletes.
- (e) The course must be verified (i.e. re-measured) as late as

possible before the race, on the day of the race or as soon as practical after the race, by a different "A" grade measurer from any of those who did the original measurement.

Note: If the course was originally measured by at least two "A" grade or one "A" and one "B" grade measurers, no verification (re-measurement) under this Rule 260.21(e) will be required.

- (f) World Records in Road Running Events set at intermediate distances within a race must comply with the conditions set under Rule 260. The intermediate distances must have been measured, recorded and subsequently marked as part of the course measurement and must have been verified in accordance with Rule 260.21(e).
- (g) For the Road Relay, the race shall be run in stages of 5km, 10km, 5km, 10km, 5km, 7.195km. The stages must have been measured, recorded and subsequently marked as part of the course measurement with a tolerance of $\pm 1\%$ of the stage distance and must have been verified in accordance with Rule 260.21(e).

Note: It is recommended that national governing bodies and Area Associations adopt similar rules to the above for the recognition of their own records.

RULE 261 EVENTS FOR WHICH WORLD RECORDS ARE RECOGNISED

Fully Automatically Timed performances (F.A.T.)

Hand Timed performances (H.T.)

Transponder Timed performances (T.T.)

Men

Running, Combined and Race Walking Events:

F.A.T. only: 100m; 200m; 400m; 800m;
 110m Hurdles; 400m Hurdles;
 4 × 100m Relay; 4 × 200m Relay; 4 × 400m Relay;
 Decathlon.

F.A.T. or H.T.: 1000m; 1500m; 1 Mile; 2000m; 3000m;
5000m; 10,000m; 20,000m; 1 Hour; 25,000m;
30,000m; 3000m Steeplechase;
4 × 800m Relay; Distance Medley Relay; 4 × 1500m
Relay;
Race Walking (Track): 20,000m; 30,000m, 50,000m.

F.A.T. or H.T.
or T.T.: Road Races: 5km*; 10km; Half Marathon;
Marathon; 100km; Road Relay (Marathon distance
only); Race Walking (Road): 20km; 50km.

Jumping Events: High Jump; Pole Vault; Long Jump; Triple Jump.
Throwing Events: Shot Put; Discus Throw; Hammer Throw; Javelin
Throw.

Women

Running, Combined and Race Walking Events:

F.A.T. only: 100m; 200m; 400m; 800m;
100m Hurdles; 400m Hurdles;
4 × 100m Relay; 4 × 200m Relay; 4 × 400m Relay;
Heptathlon; Decathlon.

F.A.T. or H.T.: 1000m; 1500m; 1 Mile; 2000m; 3000m;
5000m; 10,000m; 20,000m; 1 Hour; 25,000m;
30,000m; 3000m Steeplechase;
4 × 800m Relay; Distance Medley Relay; 4 × 1500m
Relay;
Race Walking (Track): 10,000m; 20,000m;
50,000m*.

F.A.T. or H.T.
or T.T.: Road Races: 5km*; 10km; Half Marathon; Marathon;
100km; Road Relay (Marathon distance only);
Race Walking (Road): 20km; 50km.

Note (i): Except Race Walking competitions, IAAF shall keep two World Records for women in Road Races: a World Record for performance achieved in mixed gender (“Mixed”) races and a World Record for performance achieved in single gender (“Women only”) races.

Note (ii): A women only road race can be staged by having separate women’s and men’s start times. The time differential should be chosen to prevent any possibility of assistance, pacing or interference, especially on courses involving more than one lap of the same section of the course.

*Initial record to be recognised after 1 January 2018. The performances shall be equal to or better than 13:10 (Men) and 14:45 (Women), and if no such performances are achieved in 2018, the best performances of 2018 are recognised on 1 January 2019.

Jumping Events: High Jump; Pole Vault; Long Jump; Triple Jump.

Throwing Events: Shot Put; Discus Throw; Hammer Throw; Javelin Throw.

Universal

Running, Combined and Race Walking Events:

F.A.T. only: 4 x 400m Relay (mixed)

RULE 262 EVENTS FOR WHICH WORLD U20 RECORDS ARE RECOGNISED

Fully Automatically Timed performances (F.A.T.)

Hand Timed performances (H.T.)

Transponder Timed performances (T.T.)

U20 Men

Running, Combined and Race Walking Events:

F.A.T. only: 100m; 200m; 400m; 800m;
110m Hurdles; 400m Hurdles;
4 × 100m Relay; 4 × 400m Relay;
Decathlon.

F.A.T. or H.T.: 1000m; 1500m; 1 Mile; 3000m;
5000m; 10,000m; 3000m Steeplechase;
Race Walking (Track): 10,000m.

F.A.T. or H.T.

or T.T.: Race Walking (Road): 10km.

Jumping Events: High Jump; Pole Vault; Long Jump; Triple Jump.

Throwing Events: Shot Put; Discus; Hammer Throw; Javelin Throw.

U20 Women

Running, Combined and Race Walking Events:

F.A.T. only: 100m; 200m; 400m; 800m;
100m Hurdles; 400m Hurdles;
4 × 100m Relay; 4 × 400m Relay;
Heptathlon, Decathlon*.

F.A.T. or H.T.: 1000m; 1500m; 1 Mile; 3000m;
5000m; 10,000m; 3000m Steeplechase;
Race Walking (Track): 10,000m.

F.A.T. or H.T.

or T.T.: Race Walking (Road): 10km.

Jumping Events: High Jump; Pole Vault; Long Jump; Triple Jump.

Throwing Events: Shot Put; Discus Throw; Hammer Throw; Javelin Throw.

*Only ratified if over 7300 points.

RULE 263 EVENTS FOR WHICH WORLD INDOOR RECORDS ARE RECOGNISED

Fully Automatically Timed performances (F.A.T.)

Hand Timed performances (H.T.)

Men

Running, Combined and Race Walking Events:

F.A.T. only: 50m; 60m; 200m; 400m; 800m;
50m Hurdles; 60m Hurdles;
4 × 200m Relay; 4 × 400m Relay;
Heptathlon.

F.A.T. or H.T.: 1000m; 1500m; 1 Mile; 3000m; 5000m;
4 × 800m Relay;
Race Walking: 5000m.

Jumping Events: High Jump; Pole Vault; Long Jump; Triple Jump.
Throwing Event: Shot Put.

Women

Running, Combined and Race Walking Events:

F.A.T. only: 50m; 60m; 200m; 400m; 800m;
50m Hurdles; 60m Hurdles;
4 × 200m Relay; 4 × 400m Relay;
Pentathlon.

F.A.T. or H.T.: 1000m; 1500m; 1 Mile; 3000m; 5000m;
4 × 800m Relay;
Race Walking: 3000m.

Jumping Events: High Jump; Pole Vault; Long Jump; Triple Jump.
Throwing Event: Shot Put.

RULE 264 EVENTS FOR WHICH WORLD U20 INDOOR RECORDS ARE RECOGNISED

Fully Automatically Timed performances (F.A.T.)
Hand Timed performances (H.T.)

Men

Running and Combined Events:

F.A.T. only: 60m; 200m; 400m; 800m;
60m Hurdles;
Heptathlon.

F.A.T. or H.T.: 1000m; 1500m; 1 Mile; 3000m; 5000m.

Jumping Events: High Jump; Pole Vault; Long Jump; Triple Jump.

Throwing Event: Shot Put.

Women

Running and Combined Events:

F.A.T. only: 60m; 200m; 400m; 800m;
60m Hurdles;
Pentathlon.

F.A.T. or H.T.: 1000m; 1500m; 1 Mile; 3000m; 5000m.

Jumping Events: High Jump; Pole Vault; Long Jump; Triple Jump.

Throwing Event: Shot Put.

RULE 264 S1 UKA SUPPLEMENT RECORDS

Technical Advisory Committee is responsible for the management and sanction of British records

- (1) An application for a record must be made on the appropriate form which must be forwarded with a copy of the programme, and in the case of a field event, the score card, within 14 days to the Secretary of the appropriate National Association in respect of Home Country records, by the Secretary of the body responsible for the organisation of the meeting at which the performance was accomplished.
- (2) If an application concerns a UKA National or All-comers record or in respect of a foreign athlete and the claim for a National Record, a Record of Performance form should be completed and forwarded to the Chief Executive of UKA, together with other appropriate details.
- (3) The standard record form shall, as appropriate, state or confirm:
 - (i) Place.
 - (ii) Date.
 - (iii) Name and affiliation of the competitor.
 - (iv) Performance.
 - (v) Force and direction of wind.
 - (vi) Correctness as to the distance covered by the competitor in the race.

- (vii) Correctness as to spacing and type of hurdle used and the number knocked down if not of the International type.
 - (viii) Correctness of time, distance or height claimed.
 - (ix) Correctness of weight, measurement and material of implement.
 - (x) The time at the end of each lap and the name of the leader for all events over 400m in length.
 - (xi) That the appropriate Rules of UKA and/or the IAAF have been strictly observed.
- (4) The appropriate Referee must sign the record form, confirming the accuracy of all the details included in the application form and supporting information.
 - (5) Claims for outdoor records will not be accepted if the performance was achieved on a wooden surface, or, in the case of all running and walking events, if the track was banked. Separate indoor records are maintained for which these restrictions do not apply.
 - (6) No outdoor record at a distance of 200m or more shall be accepted if made on a track exceeding 400 metres in perimeter or if not started on the perimeter, except in steeplechase events where the water jump is placed outside the normal 400 metre track.
 - (7) For outdoor records the maximum lateral inclination of tracks, runways or circles shall not exceed 1:100 and in the running direction 1:1000 downwards; any inclination should be uniform. The inclination of a throwing field shall not exceed 1:1000 downwards in the throwing direction.
 - (8) When photo finish or an approved fully automatic electrical timing device is used the time for distances up to and including 10,000m, unless recorded as an exact 1/100th of a second, shall be read and recorded to the next longer 1/100th of a second. For distances over 10,000m the time shall be read and recorded to 1/10th second. Record claims for events up to and including 400m can only be submitted when such a device has been used for timing.
 - (9) Where a record claim is made when hand timing only is in operation the performance must have been timed by three Timekeepers each of whom should be at least Level 4. Immediately after the race they shall exhibit their watches to the Chief Timekeeper who will decide which time shall be recorded in accordance with Rule 165(9) and complete the Record Application Form appropriately.

- (10) All the Track Officials signing the Record Application Form should be at least Level 4.
- (11) For records claimed in Walking Events the Chief Judge of Walking must certify that the competitor complied fully with the definition of walking. The certification shall not be given unless there are four Judges of Race Walking, of whom at least three shall be at least Level 4 or its equivalent, or be on the IAAF Panel.
- (12) In a race run wholly or partly in lanes no record shall be accepted where the athlete has run on, or inside, the inner curved border of his or her lane.
- (13) For records claimed in Field Events the distance or height shall have been measured by three Field Judges using EDM, VDM, or other scientific apparatus, which has obtained a certificate of accuracy from a nationally recognised standardising organisation. Alternatively in certain circumstances a steel or fibre glass tape, or bar may be used. The Field Referee should be at least Level 4 and the other Judges signing the result card should be qualified officials.
- (14) For all outdoor record claims up to 200m on the track and in the Long Jump and Triple Jump information as to wind conditions must be available. If the component of the wind measured in the direction of running behind the runner averages more than 2 metres per second the performance shall not be accepted as a record except as outlined in (19) below. The wind gauge must have been sighted in accordance with Rule 163, 165 & 184 as appropriate.
- (15) The periods for which the wind component shall be measured are as follows:
- | | |
|--|---------|
| All distances up to and including 100m | 10 secs |
| 100m hurdles and 110m hurdles | 13 secs |
| Long jump and triple jump | 5 secs |
| 200m. Commencing as the runners enter the straight | 10 secs |
| Wind speeds shall be recorded in accordance with rule 163, 165 & 184 | |
- (16) The record claimed must have been made in a bona fide competition included in the programme of the meeting where it was held. Record claims may be submitted for performances made in heats or qualifying trials, and in Combined Events.
- (17) No performance will be accepted in an individual event unless it has been accomplished during an official competition with a minimum

of three competitors taking part. At least two relay teams must have participated in any relay race for a record to be considered.

- (18) Except in Field Events no performances achieved in a Handicap shall be accepted as a record.
- (19) Outdoor records in Combined Events will be accepted only if performances in each event of which the competition consists are certified in accordance with the preceding paragraphs of this Rule, except that in events where wind velocity is measured, the average velocity (based on the sum of the wind velocities, as measured for each individual event, divided by the number of such events) shall not exceed + 2 metres per second.
- (20) In any race decided on the distance covered in a fixed period of time the distance achieved shall be measured to the nearest metre behind the rear edge of the last foot-print of the competitor, i.e. fractions of a metre shall be ignored.
- (21) In the case of United Kingdom records UKA will decide whether the competition was a bona fide one and shall have absolute and unfettered discretion in deciding whether to accept or to refuse a record claim. Provided the essential Rules for Competition have been observed it is a matter for UKA to decide whether the omission of any technicality can be ignored.

(22) Events for which United Kingdom All-Comers and National Records are recognised outdoors are:

Men and Women (Seniors): 100m, 200m, 400m, 800m, 1000m, 1500m, 1 Mile, 2000m, 3000m, 5000m, 10000m, 1 Hour, 25000m, 30000m, 400m Hurdles, 3000m Steeplechase, 4x100m, 4x400m, High Jump, Pole Vault, Long Jump, Triple Jump, Shot Put, Discus, Hammer, Javelin, Decathlon, 20km Walk, 2 Hours Walk, 30km Walk, 50km Walk.

Men only (Seniors): 110m Hurdles, 4x200m, 4x800m,

Women only (Seniors): 100m Hurdles, Heptathlon.

(23) Events for which United Kingdom National Under 23 Records are recognised outdoors are:

Men and Women: 100m, 200m, 400m, 800m, 1000m, 1500m, 1 Mile, 2000m, 3000m, 5000m, 10000m, 1 Hour, 25000m, 30000m, 400m

Hurdles, 3000m Steeplechase, 4x100m, 4x400m, High Jump, Pole Vault, Long Jump, Triple Jump, Shot Put, Discus, Hammer, Javelin, Decathlon, 20km Walk, 30km Walk, 50km Walk.

Men only: 110m Hurdles, 4x200m, 4x800m,

Women only: 100m Hurdles, Heptathlon.

(24) Events for which United Kingdom National U20 Records (Juniors) are recognised outdoors (using Senior or Under 20 specifications) are:

Men and Women: 100m, 200m, 400m, 800m, 1000m, 1500m, 1 Mile, 3000m, 5000m, 10000m, 400m Hurdles, 3000m Steeplechase, High Jump, Pole Vault, Long Jump, Triple Jump, Shot Put, Discus, Hammer, Javelin, Decathlon, 10km Walk.

Men only: 110m Hurdles.

Women only: 100m Hurdles, Heptathlon.

(25) Events for which United Kingdom National U18 Records are recognised outdoors (using Under 18 specifications only) are:

Men and Women: 100m, 200m, 400m, 800m, 1000m, 1500m, 1 Mile, 3000m, 400m Hurdles, 2000m Steeplechase, High Jump, Pole Vault, Long Jump, Triple Jump, Shot Put, Discus, Hammer, Javelin, 10km Walk.

Men only: 110m Hurdles, Decathlon.

Women only: 100m Hurdles, 5km Walk, Heptathlon.

(26) Events for which United Kingdom All-Comers and National records are recognised indoors are:

Men and Women: 50m, 60m, 200m, 400m, 800m, 1000m, 1500m, 1 Mile, 3000m, 5000m, 50m Hurdles, 60m Hurdles, 4x200m, 4x400m, 4x800m, High Jump, Pole Vault, Long Jump, Triple Jump, Shot Put.

Men only: 5km Walk, Heptathlon.

Women only: 3km Walk, Pentathlon.

(27) Indoor records at 200m and over are only valid if the oval track does not have a nominal length of more than 200 metres.

- (28) Additional United Kingdom National Records will be added from time to time during the duration of this rule book by UKA Technical Advisory Group for events which have become established at National championships.
- (29) **Ratification of Records and Doping Control:** Prior to ratification of a new record achieved at a competition where testing has not been conducted, a review may be undertaken of the athlete's testing history which may include checking test pool membership, test frequency etc. Where testing is present at an event where a record is broken the athlete should request a test. If the athlete fails to report for testing then they may be asked to provide an explanation for the failure to report for testing for consideration as part of the ratification process

RULE 265 OTHER RECORDS

1. Games, championships, meeting and other similar records may be established by the relevant body having control over the competition or by the organisers.
2. The record should recognise the best performance achieved at any edition of the applicable competition in accordance with the Rules, with the exception that wind velocity readings may be ignored, unless it is specifically provided otherwise in the applicable regulations for the competition.

APPENDIX 1

ULTRA DISTANCE ROAD AND TRACK EVENTS RULES

The following rules include the use of transponder technology and are now recognised by UKA for the conduct of track and road events over 30km. Long distance track events must be conducted according to the rules of the IAAF and UKA, which shall apply except where specifically modified within these Rules.

GENERAL RULES

RULE ULTRA 1

UKA authenticates track and road records and maintains lists of best performances as shown below in (a) to (c). The categories maintained are: World Record/Best Performances for distances accepted by the IAAF, United Kingdom (All Comers) Record/Best Performances and United Kingdom (National) Record/Best Performances for all categories. Any application for a Best Performance shall be sent to the runbritain/Road Running Advisory Group without undue delay, together with the supporting documents required. After the Record/Best Performance has been ratified by this group it will be included when the list of Best Performances and Records is next published.

The distance/time periods for which records and/or best performances are recognised are the following:

- (i) 20 miles, 25 miles, 30 miles, 40 miles, 50 miles and 100 miles
or
- (ii) 20 km, 25km, 30km, 50km, 100km, 150km, and 200km or
- (iii) 1 hour, 2 hours, 24 hours, 48 hours and 6 days.

RULE ULTRA 2

Track races must be held outdoors on a 400 metre track (with raised border as identified in Rule 160 S1(1)) and in bona fide competition, i.e. more than one competitor and no pacing.

RULE ULTRA 3

- (1) The track must be certified in accordance with the requirements of UKA.
- (2) Pacing may be interpreted as taking place when a runner not officially entered in the competition, or a runner entered in the competition who does not start, or a runner who has dropped out of the competition, runs more than 200 metres with the record claimant. The Race Referee has discretion to decide whether the claimant has received unfair assistance.
- (3) The event must have been advertised beforehand and a programme must have been produced bearing the claimant's name.

RULE ULTRA 4

ROAD – SET DISTANCE/FIXED TIME

Transponder timing may be employed as an alternative to manual timekeeping for road and track races. Ultra Rule 9 will apply and must be included in the event organisation in the case of a technical fault or loss of power with a transponder system.

Transponder Timing

- (1) The use of transponder timing systems is permitted provided that:
 - (i) the system requires no action by an athlete during the competition, at the finish or at any stage in the result processing.
 - (ii) the weight of the transponder and its housing carried on the athlete's uniform, race number or shoe is not significant.
 - (iii) none of the equipment used at the start, along the course or at the finish line constitutes a significant obstacle or barrier to the progress of the athlete.
- (2) At the finish the athletes shall still be placed in the order in which any part of their bodies (i.e. the torso as distinguished from head, neck, arms, hands, feet and legs) reaches the vertical plane of the nearer edge of the finish line. The Referee shall be final arbiter regarding the finishing order of the athletes.
- (3) In competitions where the Competition Provider chooses to use a

transponder timing system, each competitor must wear the necessary equipment, as directed by the Competition Provider. Failure to wear the necessary equipment as issued may result in disqualification.

Manual Timing

- (4) In every long distance road race the lap times of every competitor must be taken and recorded on a lap scoring board.
 - (5) Each competitor should have a lap scorer, though a skilled lap scorer may record more than one competitor. A lap scorer may be replaced by another during the race. Lap scorers must sign the boards/sheets they have completed any part of.
 - (6) A display clock should be placed at the finish of each lap so that the lap scorers and competitors may read the time. If this is not available, a Timekeeper must call out lap times of all competitors during the race.
 - (7) An additional record should be kept of the leader's lap times during the race.
 - (8) Any application for a Best Performance must be accompanied by the lap scoring board of the claimant and of the race leader.
- (These Rules do not apply to point-to-point races).

RULE ULTRA 5 TRACK – LAP TIMES – SET DISTANCE

Transponder Timing

- (1) The use of a transponder timing system is permitted for pre-set ultra-distance track events provided that:
 - (i) In competitions where the Competition Provider chooses to use a transponder timing system, each competitor must wear the necessary equipment, as directed by the Competition Provider. Failure to wear the necessary equipment as issued may result in disqualification.
 - (ii) the weight of the transponder and its housing carried on the athlete's uniform, race number or shoe is not significant.
 - (iii) none of the equipment used at the start, along the lap or at the finish line constitutes a significant obstacle or barrier to the progress of the athlete.

- (iv) The lap times of every competitor must be recorded on a lap scoring board, visibly accessible LCD screen at track side and/or other lap scoring systems linked to the transponder process.
- (v) A display clock should be placed at the finish of each lap so that competitors may read the elapsed time and distance.
- (vi) At the finish the athletes shall still be placed in the order in which any part of their bodies (i.e. the torso as distinguished from head, neck, arms, hands, feet and legs) reaches the vertical plane of the nearer edge of the finish line. The Referee shall be final arbiter regarding the finishing order of the athletes.

Manual timing

- (2) In every long distance track race the lap times of every competitor must be taken and recorded on a lap scoring board.
- (3) Each competitor should have a lap scorer, though a skilled lap scorer may record more than one competitor. A lap scorer may be replaced by another during the race. Lap scorers must sign the boards/sheets they have completed any part of.
- (4) A display clock should be placed at the finish of each lap so that the lap scorers and competitors may read the time. If this is not available, a Timekeeper must call out lap times of all competitors during the race.
- (5) An additional record should be kept of the leader's lap times during the race.
- (6) To reduce the likelihood of human error, lap recorders must be in an elevated, tiered seating area sited directly opposite the lap start/finish line. This should give each one a clear unobstructed view of the line and the race clock.
- (7) Any application for a Best Performance must be accompanied by the lap scoring board of the claimant and of the race leader.

RULE ULTRA 6 FIXED TIME RACES

- (1) Some long-distance road/track races are held over a fixed period of time (e.g. 24, 48 hours) rather than a fixed distance. In such races, a competitor need not necessarily be on the road/track at the end of the race, the winner being the competitor who covers the greatest distance during the period of the race.
 - (2) On completion of the fixed time, a recorder/official is responsible for marking the exact spot of each runner on the lap, which is to be taken at the rear of the runner's foot. The distance is measured by steel tape from the nearest convenient marker. All distances are to be rounded down-wards to the nearest metre.
- (Rule Ultra 5(1) (a) to (e) also applies to these events)

RULE ULTRA 7 MULTI-DAY RACES

In some multi-day track races and Ultra-distance track races the runners reverse direction every 3–4 hours. This has been found to reduce the risk of injury. When the signal is given, each runner should complete the lap currently in progress and then reverse direction. During this procedure, runners who have not yet reversed have priority in the inside lane.

RULE ULTRA 8 GENERAL CONDITIONS

TRACK – SET DISTANCE / FIXED TIME

Minor departures are allowed from normal IAAF and UKA Rules in view of the special nature of long distance track races.

- (1) The maximum number of starters for any event over 30 miles should not exceed 40 in number.
- (2) Race numbers must be worn by runners, above waist height to the

- front and rear and clearly visible, on all clothing, at all times for the duration of any type of event.
- (3) Each runner/lap recorder should be made known to each other prior to the event start. They should agree two signals: one to acknowledge to each other at the end of a lap that the lap has been completed/recorded and the other to indicate to the recorder that the runner's next lap time will be extended because they will be leaving the track for a short time. This extended lap should be indicated on the scoring board/sheet by the lap recorder (see also (6) below).
 - (4) There are no restrictions on the supply of refreshments during the race.
 - (5) A runner may be accompanied by an attendant for such purposes as refreshments and changes of kit. The attendant is not permitted to render any direct assistance to the runner's progress (this includes pacing: see Ultra Rule 3(2)), and must not interfere with other competitors or officials.
 - (6) A competitor may leave the track and return to the same place on the track provided, in the opinion of the Referee, the time off the track is not excessive.
 - (7) A competitor may claim a Record/Best Performance at a distance less than the advertised distance of the race, e.g. 100 miles in a 24 hours race or 50 miles in a 100km race.
 - (8) Women may compete in the same race as men, and female performances shall be eligible for ratification as Records/Best Performances.
 - (9) Lapped runners are not eliminated from the race.
 - (10) The runner with the greatest distance achieved during the fixed time does not have to be on the track when the fixed time ends.

RULE ULTRA 9 MANUAL TIMEKEEPING

- (1) There should be three UKA qualified Timekeepers, one of whom is appointed Chief Timekeeper, all using timers of a kind approved by UKA.
- (2) The Timekeepers must time the race independently, and exhibit their times to the Chief Timekeeper. Each of the three times must be entered on the record application form. The Chief Timekeeper shall

return the time of the race, if two timers agree and the other disagrees, as the time of the two which agree. If all three timers disagree, the middle of the three times shall be recorded as the official time. If for any reason only two timers record the time, the longer of the two shall be taken as the official time.

- (3) All times shall be rounded up to the next whole second.
- (4) In longer races, where the guaranteed accuracy of watches is greater than
- (5) ± 0.5 seconds over the period of the race, the BBC radio signal received by an AM or FM receiver should be used to judge if any correction factor is required.

APPENDIX 2

TECHNICAL OFFICIALS PATHWAY (Track & Field)

If any changes are made to this section during the lifetime of the Rule Book, they will be displayed on the UKA web-site.

The disciplines for Technical Officials are: Field Judges, Starters/Starters' Assistants, Timekeepers, Photo-finish Judges, Race Walk Judges and Track Judges. The initial grade for discipline specific Officials is Level 1 (The Assistant Officials Award (sometimes called the Club Officials' Award and the Young Officials' Award) a multi-disciplinary introduction to assisting with competition.)

Applications from those interested in becoming Officials should be made through the appropriate club, county or Home Country. Details of the relevant contact name can be obtained in the first instance through UK Athletics, Alexander Stadium, Birmingham, B90 8AJ. Tel 0121 713 8400, Fax 0121 713 8452, Email information@uka.org.uk. Other information may also be found at info@uka.org.uk

REQUIREMENTS FOR TRACK AND FIELD TECHNICAL OFFICIALS

UK Athletics and Officials' networks are working together to ensure quality, standardised experiences for new volunteers entering the sport and a clear competence based pathway for those already involved. In association with the various administration areas, a National Database of Officials has been established. All qualified Technical Officials receive a pass and licence that recognises their level of qualification. All qualified Technical Officials must hold a current DBS certificate (or Home Countries equivalent), available through UK Athletics, or, if under the age of 16, should self-declare their eligibility.

A Technical Official's pathway exists, the details of which are shown below. It should be noted that the pathway for Race Walk Judges varies slightly from that shown and full details can be found on the UKA website.

(1) Assistant Officials Award (Club Officials Award & Young Officials Award)

These are awards that qualify people to assist in officiating. They enable people to develop the following qualities, skills and knowledge at a basic level:

Qualities: to be athlete centred, fair, unobtrusive, sensitive, diplomatic, systematic, firm, focused, objective, decisive, consistent and calm.

Skills: to be able to measure distances and times; make and share judgements; record observations, judgements and data; ensure safety and report concerns; liaise and communicate with other Officials and athletes; report rule infringements; follow procedures and apply rules.

Knowledge: to know the basic rules for events and officiating procedures.

To achieve either of the awards candidates must:

- (i) Attend a workshop delivered by an approved tutor
- (ii) Complete and record a minimum of two practical officiating experiences
- (iii) Submit evidence of two practical experiences and a registration form to their Home Country association.
- (iv) Successfully complete a Health & Safety and Risk Assessment course (Club Officials Award course only)

UK Athletics are responsible for maintaining a list of new Club Officials and Young Officials and ensuring that this information is accessible to all appropriate administration areas.

(2) Level 1

The UK Athletics Level 1 qualifies Officials to operate in a single discipline – as a Track Judge, Field Judge, Timekeeper, Starter/ Starters' Assistant or Photo-finish Judge. Beginner Officials are able to enter the system at Level 1 if they are aware of the discipline in which they wish to officiate and have prior experience within the sport.

To achieve Level 1 Officials must:

- (i) Successfully complete the Introduction to Officiating course.
- (ii) Successfully complete the Health & Safety and Risk Assessment course.
- (iii) Attend a discipline specific workshop delivered by an approved tutor
- (iv) Complete Record Sheets showing evidence of officiating at a minimum of four (4) meetings (for Field Judges this must

include judging at least one horizontal jump, one vertical jump and the throws, including both the Shot Put and long throws. For starters, this should include four experiences as a Starter and four as a Starters' Assistant.)

Note: Officials cannot qualify at Level 1 or above, in any discipline, until they have successfully completed the UKA Track & Field Health & Safety course module.

Note: Officials cannot judge in the landing sector in any throwing event until they have successfully completed the UKA Track & Field Health & Safety course module.

(3) Level 2

To progress to **Level 2** they must also:

- (i) Complete a logbook including providing evidence of officiating at a minimum of ten (10) meetings. (The Record of Experience form can be used for this purpose), plus one report.
- (ii) Work with an appropriate mentor who may have been formally appointed on their behalf or informally through their own contacts.
- (iii) Submit relevant sections of their logbook for assessment (to an approved assessor) and meet assessment criteria. The system of appointment of assessors will be finalised during the lifetime of this Rule Book.

Note: Officials cannot act as a Chief Judge of a long throw event until they have reached Level 2, due to the fact that, until that point, there is no compulsion on them having officiated at any more than one long throw competition.

(4) Level 3

To progress to **Level 3** they must also:

- (i) Complete a logbook including providing evidence of officiating at a minimum of an additional ten (10) meetings (the Record of Experience form can be used for this purpose) plus one report.
- (ii) Work with an appropriate mentor, as described above.
- (iii) Submit relevant sections of their logbook for assessment (to an approved assessor) and meet assessment criteria as described

above.

As further experience is gained within Level 3, Officials will have that experience recognised. During this period they may start to request for reports on their performance to be given to them, so that they can, if they wish, progress to Level 4, as described below. There are specific reports required, and details are shown in the section on Level 4.

UK Athletics are responsible for maintaining a list of all licenced Officials and ensuring that this information is accessible to all appropriate administration areas.

(5) Level 4

The UK Athletics Level 4 is a progression from Level 3 that both consolidates learning at Level 3 and prepares the Official to operate at national and international level through the introduction of additional modules including meeting management and the use of appropriate technology. Officials who have satisfied the requirements of the Level 4 accreditation system will be listed as Level 4P for two years after qualification but will immediately become eligible to receive information regarding selection for national and international competitions under the auspices of UKA. This is a probationary period during which positive assessments are required in order for the Official to remain eligible for consideration for selection for such competitions. Should such assessments not be received the Official will retain their Level 4 designation but will no longer be eligible for selections as mentioned above. Detailed guidelines for applicants for Level 4 are produced annually and displayed on the UKA website.

To achieve Level 4 Officials must:

- (i) Attend a generic workshop delivered by an approved tutor
- (ii) Attend a discipline specific workshop on a chosen area relevant to their discipline, including all of the areas available at Level 4, including photo-finish.
- (iii) Attend a technology workshop specific to their own discipline, including Automatic False Start Equipment, Photo Finish and EDM,
- (iv) Complete a logbook.

- (v) Show evidence of officiating at a minimum of thirty (30) competitions within three years, and submit at least six (6) positive reports from appropriate Officials as described below.
- (vi) Work with an appropriate mentor
- (vii) Submit logbook for assessment and undergo assessment of competence and knowledge and understanding of UKA and IAAF rules and the differences between them by an approved assessor.
- (viii) Submit reports of successful experience at a minimum of six events, to include specific duties.

The Reports:

- One as a Chief Official / Referee at a League Match or County Championship or similar equivalent event.
- Two as a member of a team of Officials.
- One from a reporter outside your Region or other Home Countries equivalent.
- One as Clerk of Course
- One using relevant Technology.

Reports must be written by Officials who have supervised the Official. The reporter must be at least in Level 4, with a minimum of two years at least in Level 4. The Technology report may be written by the same Official as one other report, but at a different competition. Other than this exception, all reports must be by different Officials.

The Level 4 qualification recognises all Technical Officials at that level as National Technical Officials, equivalent to Level 1 Officials under the IAAF TOECS (Technical Officials' Education & Certification System). Any level 4 Official who has not submitted their records of experience and availability forms for a period of three years will be considered to be inactive at National level and will no longer receive availability requests. They may apply for re-instatement through their TRNG.

(6) Level 5

Candidates will be recognised as competent to operate at the highest level of the sport within the United Kingdom and be capable of becoming nominees for European Athletics and IAAF appointments. Assessment procedures include a course and an examination equivalent

to the IAAF Level 2 course and examination.

Officials qualified at Level 4 may be invited to apply for accreditation at Level 5. To be eligible, candidates must:

- Be a Level 4 Official who has been on the UKA Active List for at least the previous 5 years. (This time scale can be reduced in exceptional circumstances).
- Be a member of the IMO group in the year of the invitation for accreditation.
- Have gained the Competition Management Award (see description below).

A Level 5 Official must be capable of carrying out a wide range of roles at any level of the sport, from grassroots to International level, and:

- Has proven ability to act as Discipline Referee/Chief and in Competition Management at International level, including at events for athletes with a disability.
- Has demonstrated ability to report on meetings and Officials, both in writing and verbally.
- Is knowledgeable in all disciplines and able to demonstrate that knowledge by successful completion of an examination.

As part of the application process, candidates must show evidence of:

- Successful experience in the position of Chief / Referee and senior management positions at national and international events during the previous four years.
- Qualification in two other disciplines, as described above.
- Working at events for athletes with a disability.
- Participation in events in a range of duties other than as a discipline specific Technical Official including such roles as Meeting Manager, Call Room etc. as appropriate.
- Mentoring of other Officials.

In addition, candidates must attend a course specially staged on the requirements and knowledge base required to be capable of attempting the examination which forms the basis of qualification at this level.

Appointment to Level 5 is normally for a four year period. In order to

maintain this accreditation the Official must attend a refresher course and successfully complete the examination.

The course and examination will take place at least once in every four years, with an examination held in the year leading up to the European Athletics examination, so that those deemed to have been most successful will be considered for entry to the EA examination as the nominees of UKA, if eligible and if places are available for nomination.

(7) The International Meetings Officials Group (IMO)

The IMO group is made up of those members of the Level 4 and Level 5 list who are regarded by their peers as being outstanding technicians in their discipline. The list is determined each year and used to assist in the following year's selection of Officials for Major competitions. Members of the group will, under normal circumstances, including their availability and the number of fixtures to be held at that level, be assigned to at least two Major competitions during the year.

In order to be considered for membership of the IMO Group, and to remain on the list, Officials must satisfy the requirements as published on the UKA web-site which include demonstrating their competence, making themselves available for a minimum of four (4) Level 2 / Major Licence Meetings in a calendar year and providing evidence on a Record of Experience form of having officiated at a minimum of twenty (20) days of track and field athletics each year. (Further details of the requirements can be found in Appendix 3 under "Selection to International / National meetings").

UK Athletics are responsible for maintaining a list of Level 4 Officials as well as the IMOG and ensuring that this information is accessible to all appropriate administration areas.

(8) Competition Management Award

Officials qualified at Level 3 and above may apply to take the Competition Management Award, which recognises their ability to become part of the management team at events at all levels.

An Official with this award may be described as an Official with a wide

range of experience who has proven ability to:-

- Act as Referee/Chief in a technical discipline, including completing reports on meetings and Officials on time.
- Work in roles other than as a discipline specific Technical Official at a range of meetings.
- Officiate competently at events for athletes with a disability.
- Act as a mentor to other Officials.

Candidates for the award must attend three compulsory modules, which are

- (i) Management Structure and Leadership
- (ii) Mentoring, assessment and reporting
- (iii) Disability (either track or field)

They must also attend two of the optional modules, which are

- (i) Meeting Manager
- (ii) Call Room
- (iii) Technical Information Centre (TIC)
- (iv) Disability (the module not taken in 4.3)

Attendance at the Management Structure & Leadership module is recommended for Officials who wish to act as Chief or Referee at a national or international event.

Assessment for this award will be by

- Observation of the candidate in the position of Chief / Referee at two appropriate meetings.
- Evidence of working at events for athletes with a disability (by production of the Annual Record of Experience).
- Careful scrutiny of the annual record, which needs to show a range of duties carried out other than as a discipline specific Technical Official including such roles as Meeting Manager, Call Room Manager etc as appropriate. The candidate may also be asked to provide a statement summarising this experience.
- Evidence of mentoring, including the provision to request a statement from the candidate as to the mentoring they have done, and contacting some of those who have been mentored.

Officials at Level 2 and above may, for their own benefit, take part in any

courses which are part of the Competition Management Award for their own development.

SELECTION & RECORDS OF OFFICIALS

Peer Groups

The mechanism by which Officials are selected for Televised, International and National meetings is by offering themselves when invitations are published. Invitations are sent to all Level 4 and 5 Officials, including Level 4P Officials, as described above).

Peer Group members are elected by their peers. To be eligible to be nominated, a Level 4 or 5 Official must be a member of the Discipline Management Group.

Complete details of the selection process and election process to Peer Group are contained in Appendix 3.

Affiliation of Officials

All Officials are part of a single database. This database, with appropriate security, contains the Official's personal details and qualifications (complete or in progress). In England it will hold their primary memberships of County, Region and Tri-Regional Group whilst in Scotland, Wales and Northern Ireland it will hold their Regional, District or national membership as appropriate. Officials will have, within reasonable parameters, complete choice over each of these primary affiliations, rather than purely by postcode. Officials will be able to access their own data entry and Tri-Regional and County Officials Secretaries will have access to their relevant lists. Protocols for access and updating data are in place.

Tri-Regional and National Officials' Groups (TRNG) comprise Officials groups from:-

- **Northern Ireland**
- **Scotland**
- **Wales**
- **Three English Tri-Regional Groups which are:-**
 - Northern Group** - comprising North West, North East and

Yorkshire & Humberside

- **Midlands and South West Group** - comprising East Midlands, West Midlands and South West
- **Southern Group** - comprising South East, East and London.

Each of the six TRNGs will have either their own Peer Groups reflecting those that exist in UKA or ensure that they have an appropriate mixture of technical expertise and representation.

Officials Tri-Regional Group selection Officials make their own choice of which TRNG list they belong to, through their affiliation (below), which is particularly relevant in areas where there may be divided loyalties.

OVERSEAS APPOINTMENTS

All Officials who are invited to officiate at competitions overseas must first seek the approval of UKA. If the appointment is by an International Federation (European Athletics, IAAF or IPC Athletics) those Officials who have qualified as international Officials through the system approved by UKA should inform UKA of their appointment as a courtesy. For any other appointments by organisations (including the above, plus any others), invitations from other National Federations or any others not included above, Officials must request approval by writing to UKA (by email or post) giving full details of the invitation. The letter should include details of the competition and the host organisation's address details for UKA to enquire further should they need to do so.

Failure to follow this procedure could result in disciplinary action being taken against the Official concerned, including, but not confined to, suspension of their Licence.

FIREARMS CERTIFICATES FOR STARTING OFFICIALS

The Home Office guidance to the police on establishing good reason to possess a firearm for the purposes of starting races at athletics meetings is that starters should have achieved level 3 under the UKA structure. The Official must have a letter of approval issued by the Technical Advisory Group and signed by the UKA Welfare Officer.

UKA will supply a letter of recommendation for each starter of the appropriate level who is renewing their licence.

Whilst this is not reflected in the text agreed with the Home Office, it is in the terms agreed with the Home Office and is part of their guidance document to each of the police forces.

The UKA Welfare Officer arranges the reimbursement of the licence fee on the completion of the letter and the receipts have been received.

HANDBOOKS AND INSTRUCTIONAL BOOKS

UKA Rules for Competition effective 1st April 2018

IAAF Competition Rules effective 1st November 2017 (which incorporates The Referee instructional document)

Both are available on the IAAF website: <https://www.iaaf.org/about-iaaf/documents/rules-regulations>

World ParaAthletics Rule Book available on the IPC website:

https://www.paralympic.org/sites/default/files/document/180112123931374_World+Para+Athletics+Rules+and+Regulations+2018-2019+-+January+2018.pdf

APPENDIX 3

APPOINTMENT OF, DUTIES OF & SELECTION OF OFFICIALS

TECHNICAL OFFICIALS (Track & Field)

If any changes are made to this section during the lifetime of the Rule Book, they will be displayed on the UKA web-site.

(1) APPOINTMENT OF OFFICIALS

Officials reading the 2018 UKA Rules for Competition will note that this edition not only includes the IAAF Rules, but, for the first time, the former contents of “The Referee”, the instructional document which gave advice and explanations of how to put the rules into action. Officials should be aware that this section of the rules gives advice on the number and placing of officials at international competitions, and that these numbers and positions may not always be achievable under normal conditions of club competition. It should be highlighted here that the safety of all concerned is paramount, and so as many positions as can be appointed should be appointed, and as many positions as possible should be covered.

- (i) The following officials should be appointed at every Track and Field Meeting:

A Referee for Track Events

A Referee for Field Events. If there are to be several field events it may be desirable to appoint two Field Referees, one for the throwing events and one for the jumping events. (In meetings with many field events, further sub divisions of the Field Referee’s duties may be carried out by the appointment of further Referees for specific duties.)

Track Judges/Umpires

Field Judges

A Chief Timekeeper

Timekeepers

A Starter – two if there are many track events, one of whom should then be designated Start Coordinator, supported by a Starter’s Assistant and two or more if there are many track events, one of whom should then be designated as Chief Starter’s Assistant.

Clerks of Course

Announcer(s)

Competitors’ Steward(s)

Recorders and other Stewards as may be necessary.

Walking Judges (where walking events are included in the programme).

- (ii) The following additional officials should be appointed for meetings at level 3 and above:

A Meeting Manager, who shall have overall responsibility for the control of the meeting

A Photo-finish Team (as required)

Additional Starter(s) so that there is a team of not less than 3, thereby enabling

Start Recallers to be used (see below).

A Technical Manager/Equipment Officer

Electronic Distance Measurement Team (as required).

Scoreboard Operators and two-way Radio Stewards

Call Room Stewards

Seeding Officers

Press and Results Stewards

Presentation Stewards

Doping Control Stewards

- (iii) The following additional officials may be appointed by the Technical Advisory Group for National and International Meetings:

National Technical Delegate

Jury of Appeal

Competition Director

Technical Manager (formerly known as Technical Director at such meetings)

- (iv) Duties of Technical Officials

All officials share the responsibility for events starting to time and for the meeting to be run smoothly and safely without

undue waste of time. Officials should always consult the Rules for Competition and Track & Field Safety Guide for Competition before going to an athletics meeting.

(2) EVENT MANAGEMENT ROLES (Appointed by UKA Technical Advisory Group for all meetings promoted by UKA)

(a) NATIONAL TECHNICAL DELEGATE

- (i) Oversee organisation from appointment to completion of competition reports.
- (ii) Be the first point of contact for the relevant competition, for issues from the UKA office.
- (iii) Proof read, and approve all materials sent out to officials prior to the meeting. (From January 2013 the UKA Officials Manager will act as the link to the NTD from the Competitions Department and will be copied in to all communications from England Athletics)
- (iv) Oversee and manage the completion of all competition reports relevant to the meeting.
- (v) Chair the briefing of Chief Officials, in doing so; establish the competition rules and regulations of the event in question.
- (vi) Monitor the briefings of officials by the Chief (this should be done in conjunction with Jury of Appeal members).
- (vii) Ensure all technical checks are carried out by the Technical Manager and his team.
- (viii) Monitor the seeding and draws in track and field events where appropriate.
- (ix) During the competition observe a representative sample of technical aspects of the officiating. In doing so, accrue a range of information about the meeting conduct (as in an ITO role.)
- (x) In conjunction with the Chair of the Jury of Appeal (where appointed) ensure that a schedule is prepared for JoA members to act as event observers, taking on this part of the role of ITOs.
- (xi) Evaluate the performance of chief officials and event managers – this may be in conjunction with others.
- (xii) Receive copies of all reports post the completion of the event and collate
- (xiii) Prepare a report for UK Athletics.

- (xiv) Inform future post holders and the future event planning process.
- (xv) Establish that all relevant paperwork has been sent to all competition officials.
- (xvi) Confirm with Event Management that all necessary preparation has been completed prior to meeting to brief Chiefs.

(b) JURY OF APPEAL

- (i) In addition to their role as defined in the IAAF Rules for Competition, the Jury of Appeal act as the NTD's 'eyes and ears.'
- (ii) They will be allocated by the NTD to observe the discipline briefings, supplying brief written feedback on each to the NTD.
- (iii) The Chair of the Jury of Appeal will prepare a schedule allocating each member of the jury as observers to as many events as is feasible. In doing so they act as 'pseudo ITOs/Area ITOs'. It is important to note, however, that they should not directly intervene in the conduct of an event, as ATOs/ITOs are now authorised to do. Instead, they should draw any concerns to the attention of the judge in charge of an event.
- (iv) It is important that they be seated wherever possible and remain as unobtrusive as possible.
- (v) At the conclusion of the event they should supply feedback to the NTD.
- (vi) They are not there to assess officials, that is the responsibility of assessors where appointed, or Referees.
- (vii) In the event of a protest, the Meeting Manager will act as secretary to the Jury of Appeal.

(c) COMPETITION DIRECTOR

- (i) Co-ordinate timetable planning and sign off the final version as workable. In doing so work in close consultation with Event Production, Broadcasters and UKA/England Competitions Department staff.
- (ii) Advise Chiefs/Referees, in advance of any timetabling or production issues which may impinge on the conduct of their duties, including arrangements for athlete introductions.

- (iii) Design procedures and routes for the safe movement of athletes through the various stages of the competition process. In doing so, ensure that:
- (iv) Plan safe routes from the Call-Room to event starts and sites, ensuring that these are agreed and communicated to appropriate officials
- (v) Ensure that Referees are briefed and understand the system for getting athletes safely through the mixed zone and into presentation. Also confirm with Start Co-ordinator procedures for escorting any disqualified athletes from the start.
- (vi) Run the meeting safely and to time.
- (vii) Wherever possible, be at the start of each track and field event.
- (viii) Produce a detailed call-up schedule for officials to use.
- (ix) Prepare a simplified call-up schedule for display to athletes.
- (x) Produce guidance notes for chief officials.
- (xi) Be the link during the event to Event Presentation production.
- (xii) Be the final decision-maker on the conduct of the meeting, dealing with such issues as may arise.

(d) MEETING MANAGER

The Meeting Manager shall assume overall responsibility for the running and control of the meeting. Duties may include:

- (i) Ensuring that pre-event facility and equipment safety checks are carried out.
- (ii) To approve expense claim forms during the meeting.
- (iii) To supervise receipt bib numbers from event organisers, where appropriate, and deliver these to number stewards.
- (iv) To agree with the press/ photocopying centre a number of start lists to be printed and put aside for competition management. Collect and distribute these to all those who need them.
- (v) To obtain a master set of technical lists (field cards) from Results Company, copy these and distribute as necessary.
- (vi) To supervise the distribution and collection of radios.
- (vii) To ensure that all required personnel are in place and liaise with relevant Chiefs to arrange substitutes as necessary.
- (viii) To supervise any necessary system for the distribution of draw-sheets and results.
- (ix) To collect hard copies of field cards and deal with any record

forms – a stock of relevant record forms to be available for completion by Chiefs.

- (x) To act as Secretary for the Jury of Appeal.
- (xi) To maintain a trackside presence throughout the meeting, whenever possible, dealing with such issues as may arise from time to time.
- (xii) To deal with any issues relating to accommodation.
- (xiii) To agree the dress code and inform officials.
- (xiv) To work with UKA staff or other appointees to ensure that the following are carried out:
 - Meeting and greeting officials including collection and checking of expense claim forms.
 - Distributing programmes to officials.
 - Supervising the distribution of any clothing.
 - Supervising the collection of packed lunches, or other dining arrangements.

(e) TECHNICAL MANAGER

- (i) Ensure that all meetings are conducted in accordance with IAAF/UKA rules for competition, technical requirements and in line with safe practices detailed in UKAs Track & Field Safety Guide for Competition.
- (ii) Carry out pre-event venue safety and technical inspections.
- (iii) Liaise with Chiefs prior to events with regard to technology being provided, etc
- (iv) Agree the location of all field events taking into account any safety requirements.
- (v) Ensure that any necessary repairs/upgrades are carried out.
- (vi) Ensure that all event sites are safe and fully equipped on the day.
- (vii) Ensure that appropriate implements and all other equipment are available.
- (viii) Liaise with the Equipment Officer, before and during the event.
- (ix) Be the sport's link to technical service providers – TV, Event Presentation, Sports Timing, Results company and venue staff.
- (x) Be the sole arbiter of the final positioning of all equipment, including technical service providers' and TV equipment. Similarly, the placement of all Sports Science equipment and

personnel.

- (xi) Maintain a trackside presence throughout the meeting, dealing with such issues as may arise from time to time.
- (xii) Supervise the work of venue staff, through their managers/supervisors.
- (xiii) Supervise the work of kit-carriers.
- (xiv) Produce site plans for each event at each venue with positions for officials, equipment, etc. as required. Sign these off, if produced elsewhere.

(3) TECHNICAL OFFICIALS

(a) The Equipment Officer and Clerks of Course Shall:

- (i) Ensure that all venue equipment necessary for the competition is available, prepared and made available at the correct time along with the Clerks of Course.
- (ii) Ensure that any venue and personal implements are marked appropriately, checked and presented for the competition at the correct time for the relevant competition. Any implements that do not conform should again be marked appropriately and the reasons conveyed in particular to the relevant athlete.
- (iii) Ensure along with the Clerks of Course that equipment no longer required is removed in a timely fashion.
- (iv) Ensure along with the Clerks of Course that all equipment and implements are cleaned and returned to the appropriate store/place at the end of the competition.
- (v) Where relevant ensure that any implement involved in a record performance is rechecked and if correct confirmed with the relevant Referee.
- (vi) Shall be responsible for ensuring that the track, runways, circles, arcs, sectors, landing areas for field events and all equipment are in accordance with specification in Rules for Competition. They shall normally have overall supervision of all of the appointed Clerks of Course and shall be responsible for allocating their duties.
- (vii) In conjunction with the Track Referee, one or more of the Clerks of Course shall ensure that the course is correctly set out and kept perfectly clear. When hurdles and steeplechase races

are included in the programme, the Clerk must ensure that all hurdles and barriers are correctly set and placed and that they are removed from the track when no longer required. In addition, the Clerk shall ensure that all equipment such as judges' stand, bell, batons, etc. are safe and ready for use.

- (viii) In conjunction with the Field Referee, the Clerks of Course shall ensure that all markings are correct as required by the Rules for Competition, that take-off boards are clean and firm and landing areas safe and ready for use. The Clerks shall ensure that all equipment necessary for maintaining runways, circles and landing areas is in a fit state for competition, that brooms, rakes, rollers, etc. are available as required and that Judges are provided with marking spikes and tapes as necessary.

They are responsible for the provision of implements for practice and competition and must see that all implements are removed from the site of the event as soon as the competition is completed.

(b) The Field Referee

Shall:

- (i) have charge of all field events;
- (ii) administer the rules for competition relating to disqualification of athletes;
- (iii) allocate Judges to particular events and duties;
- (iv) check that equipment and markings conform to specification rules in liaison with the Technical Manager/Equipment Officer (if appointed) or the Clerk(s) of Course;
- (v) Ensure that all field events are conducted in line with safe practices detailed in UKA's Track & Field Safety Guide for Competition.

Note: This should be done in liaison with the Technical Manager / Equipment Officer if appointed.

- (vi) announce to Judges and ensure that the competitors are informed of the number of trials;
- (vii) ensure that all field events commence at the due time;
- (viii) supervise the measurement of performances;
- (ix) check the final results;
- (x) decide in the event of any difference of opinion between the

- Field Judges: the Field Referee's decision shall be final;
- (xi) deal with any disputed issue as provided by the Rules for Competition.

(c) Field Judges

Shall

- (i) see that field events are carried out safely and in accordance with the Rules for Competition;
- (ii) decide in which order the competitors shall be placed;

In jumping for distance, separate Judges shall be responsible for:

- deciding if the take-off is fair;
- marking the point in the landing area from which measurement is to be made;
- operating the wind gauge (the operator shall measure and record the wind speed for the designated period of time and relay this information to the Judge in charge of the event).

In jumping for height, two Judges should keep a record of the jumps and check their recordings at the end of each round. The height of the bar should be measured when the bar is raised, particularly if standards or records are being attempted.

In throwing for distance, separate Judges shall be responsible for:

- deciding if the delivery is fair;
- marking the point of landing of the implement from which the measurement is to be made.

Before the start of each event the Judges should ensure that the correct competitors are present, that they are correctly dressed and are wearing numbers as on the programme and in accordance with the Rules for Competition.

- (d) **Measurement Officials** may be appointed, especially if Electronic/Virtual Distance Measurement is to be used, and they are then responsible to the Field Referee for measuring and recording distances.

(e) The Track Referee

Shall:

- (i) have charge of all track events;
- (ii) Ensure that all track events are conducted in line with safe practices detailed in UKAs Track & Field Safety Guide for Competition.
Note: This should be done in liaison with the Technical Manager / Equipment Officer if appointed.
- (iii) administer the Rules for Competition relating to disqualification of athletes;
- (iv) allocate duties to Track Judges and Umpires;
- (v) decide in the event of any difference of opinion between the Track Judges: the Track Referee's decision shall be final;
- (vi) deal with any disputed point as provided by the Rules for Competition.

If, in the opinion of the Track Referee, circumstances arise so that justice demands that a race already concluded should be contested again, the Referee shall have power to declare the race void and it shall be contested again, either on the same day if practicable, or on some future occasion. The Track Referee has absolute discretion to decide when the race shall be re-run.

(f) Track Judges and Umpires

Shall:

- (i) see that the proper distance of each run is covered;
- (ii) decide the order in which the competitors finish.

Lap scorers should be appointed for races of longer than 1500m to record each competitor completing each lap. The duty of lap scorer can be incorporated with that of 'finish judge'.

One of the scorers shall call, or show by number cards, to the competitors the number of laps still to be completed and ring the bell for each competitor to indicate the start of the last lap. Judges should be allocated as Umpires to watch the competitors, especially on bends and over hurdles and water jumps, and shall report promptly to the Referee any infringement of the rules of racing.

Any breach of the Rules should be reported to the Referee even if the athlete (or team, for relay races) does not finish the race. Judges should also be allocated to supervise relay take-overs and to work out the results of team races.

A Wind Gauge Operator should be appointed for races up to and including 200m if the gauge is not automatic, with the reading electronically transferred to the result system. The operator should measure and record the wind speed for the designated period of time and relay this information to the Track Referee.

(g) The Start Coordinator

Shall:

- (i) allocate duties to the other Starters;
- (ii) administer the Rules for Competition relating to disqualification of athletes at the start of races;
- (iii) have absolute control over all matters relating to the start;
- (iv) ensure that the track events keep to timetable.

(h) Chief Starter's Assistant

Shall:

- (i) allocate duties to the other Starter's Assistants;
- (ii) assist in keeping the track events to timetable.
- (iii) Starters and Starters Assistants

The Starter shall have complete control of the starting of a race. Starters Assistants are appointed to act under the direction of the Starter, to make the draw for the stations at the start (if Seeding Officers have not been appointed) ensuring that the correct competitors are present, correctly dressed and wearing numbers in accordance with the programme. Starters Assistants should then assist the Starter, at his/her instruction, in watching for infringements of the rules during the starting procedure.

At meetings of a higher level, Start Recalls are appointed from within the team of Starters. If in the opinion of the Starter or Start Recaller, the start was not fair, the competitors must be recalled. In practice, the first opportunity to recall rests with the Starter, whose decision on whether to issue a false start warning shall be final.

(j) The Chief Timekeeper

Shall:

- (i) allocate duties to the Timekeepers on the team;
- (ii) declare the time to be recorded for each competitor;
- (iii) administer the Rules for Competition applicable to timekeeping.

(k) Timekeepers

Shall:

- (i) Time each event independently and, in the event of a difference between their returns, should exhibit their watches to the Chief Timekeeper, who shall decide which time is to be returned.
- (ii) Act as back-up in the event that Fully Automated Photofinish is in operation.

(l) The Chief Photo-finish Judge

Shall:

- (i) be responsible for the functioning of the equipment (in conjunction with Equipment Providers);
- (ii) initiate with the Start Coordinator, a zero gun test before the start of each session;
- (iii) supervise the testing of the equipment and ensure that the cameras are aligned;
- (iv) allocate duties to the Photofinish Judges on the team;
- (v) determine and issue the correct placing of the athletes and their official times.

(m) Photo-finish Judges

Shall: record the finish of each race and read the times and positions of each athlete; they shall provide this information to the Chief Photofinish Judge who shall decide the official result.

(n) Walking Judges

Shall: disqualify any competitor whose mode of progression they consider fails to comply with the definition of walking in the Rules for Competition.

(4) OTHER OFFICIALS

(a) Chief Seeding Officer

Shall: be responsible for the management and duties of the Seeding Officers

(b) Seeding Officers

The Seeding Officers shall have the responsibility of allocating competitors in track events to heats or subsequent qualifying rounds according to their previous best performance. They shall prepare the draw for the finals. In the case of heats (first rounds) if possible, the seeding shall be based on the best performance at previous meetings during the current or previous season. In the case of subsequent rounds, the seeding shall be based on the performance in the earlier heats (previous rounds) for events up to and including 400m, and in events above this distance the original performance list should be used, unless a better performance was achieved in the previous round.

Seeding Officers should consult with the Track Referee before the start of the meeting to establish the qualifying conditions which the Track Referee would wish to have implemented for progressing to subsequent rounds/finals.

A random draw for lanes should be made wherever possible.

Rule 166 S1(1) states “In the preliminary rounds of races, at least the winner, and preferably the winner and second should qualify for the next round or final. Any other competitors to qualify shall be decided either according to their places or according to their times. Where any qualifying position is decided by time, only one system of timing may be applied in determining times. Where photo-finish equipment is in use the Chief Photo-finish Judge shall consider, where necessary, the actual time recorded in 1/1000ths of a second by the competitor in deciding qualifiers by time”. (A mixture of hand and electric times shall not be used for the same qualifying conditions).

In National Association Championships, seeding and draws may be carried out in accordance with IAAF Rule 166.

(c) The **Call Room Manager** shall be responsible for supervising the safe transit from the warm-up area to the competition area to ensure that the athletes, after being checked in the Call Room, are present and ready at the competition site for the scheduled start of their event.

(d) The **Call Room Stewards** shall be responsible for seeing that all competitors are dressed in accordance with the Rules for Competition. They must produce the competitors for each event at the appropriate marshalling point at the time required by the Call Room Manager and furnish the official with a list of competitors.

(e) The **Numbers' / Athlete Registration Stewards** shall be responsible for seeing that all competitors are issued with the number/name bibs allotted to them in the programme for each particular event.

(f) **Announcers, Results Stewards, Press Stewards**, together with other officials as may be necessary or desirable, should also be appointed depending upon the importance of the meeting and the number of events and competitors.

APPENDIX 4

ENDURANCE RUNNING

Endurance Disciplines and Definitions

UKA and the four National Associations (England Athletics, Athletics Northern Ireland, Scottish Athletics and Welsh Athletics) regulate competition, either directly or indirectly, for the disciplines of Road Running (Rule 240), Cross Country (Rule 250), Race Walking (Rule 230), Fell and Hill Running (Rule 251) and Trail Running (Rule 252). Mountain Running events, under World Mountain Running Association (WMRA) Rules, are promoted in the UK (see the section below where we define the different disciplines).

The term “multi-terrain race” is in common usage but these events should be classified within Road Running for licensing standards.

Ultra races are held at distances exceeding the Marathon. Races may be hosted on road, trail or track and may be based on either distance or time. Ultra races shall be held under the UKA Rules for Competition for the endurance discipline that most closely reflects the nature of the event.

Fun Runs and parkruns are further additions to the accepted disciplines and definitions are offered below.

Road Running

Road Races shall be run on tarmac, concrete or paved roads. When traffic or similar circumstances make it unsuitable the course, duly marked, may be on a bicycle path or footpath alongside the road, but should not be on soft ground such as verges or the like. (UKA Rule 240 S1(2))

Guidance provided by the Association of UK Course Measurement is available at: <http://www.coursemeasurement.org.uk/>

A firm off-road surface such as smooth grass or dirt can be measured with an accuracy of about 1% using a calibration done on a road surface. The

maximum amount of such off-road surface which could be used and still retain the overall accuracy of measurement of a road race:

- Up to 10kms: 10% off-road allowed (on “smooth grass or dirt”).
- Excess amount over 10kms: 5% off-road allowed

For a number of popular race distances this gives the following lengths of off- road surface:

- 5k: 0.5 km
- 10k: 1 km
- 10 miles: 1.3 km
- Half marathon: 1.6 km
- 20 miles: 2.1 km
- Marathon: 2.6 km

For races which exceed the above amounts of off-road surface it may be impossible to issue a certificate of course accuracy. These races should therefore be classed as multi-terrain on the licence application form.

Multi Terrain

Multi Terrain, although not a discipline recognised within UKA Rules for Competition, is closely aligned to Road Running. Multi Terrain races are defined as those up to and including marathon distance which do not meet the full definition of Road Races within the rules, but are run over at least 40% tarmac, concrete or paved roads.

Road Running rules and standards, where applicable, are applied to Multi Terrain races. Multi Terrain races shall be licensed by runbritain. Where a Multi Terrain licence has been issued the race prospectus and entry form should state that the event is held under UKA Rules for Road Running, where applicable to Multi Terrain events.

Any off-road race that falls outside the definition of Multi Terrain shall be

held under the UKA Rules for Competition for the endurance discipline that most closely reflects the nature of the event, and licences for such races shall be issued by the organisation that manages and regulates that endurance discipline.

Trail

UKA defines Trail races as follows:

- (1) Trail races are races that are predominantly along:
 - (i) footpaths, bridleways and towpaths over which there is a public right of way.
 - (ii) private paths with the consent of the owner or occupier as appropriate.
 - (iii) trails across land and coastal margins where relevant legislation grants the right of public access on foot. (Such legislation includes the Countryside and Rights of Way Act 2000, and the Land Reform (Scotland) Act 2003)
- (2) Trail race routes may include connecting stretches of public road and/or private or public land without a path when the owner's permission has been obtained, if required for legal access.
- (3) Courses of up to marathon distance, i.e. 42.2km, which are less than 60% are not to be classified as Trail Races.
- (4) For Championship events the courses must be at least 60% trail if the race is 40 miles or more, 70% if the race is over 20 miles but less than 40 miles, and 80% if 20 miles or less.
- (5) Trail races may be of any length. Their length and the total climb should be measured using accurately scaled maps, such as Ordnance Survey maps, or GPS systems.
- (6) Most trail races are traditional point to point races, but some involve unusual features:
 - (i) 'Supported Races' are those where coaches, families or team managers are permitted to give competitors refreshments or provide changes of clothing along the course.
 - (ii) 'Self Sufficiency Races' require competitors to carry everything they need, except that in ultra races and in hot weather the organiser may provide water at intervals to prevent dehydration.
 - (iii) 'Kanter Races' require competitors to choose their own routes using trails and a sequence of visiting check points. These are

given as grid references on Ordnance Survey maps. Any restrictions about the choice of route should be made clear in the rules of the particular race.

- (iv) ‘Staged Races’ are those where the course is broken into separate stages with rests at the end of each stage. Competitors run every stage and their times are aggregated to determine the winner.
- (v) ‘Extreme Races’ are self-sufficiency races of over 100km that include a section most competitors will run at night.
- (7) ‘Waymarks’ are permanent official signs.
- (8) ‘Routemarks’ are temporary signs placed out by race organisers.
- (9) ‘Ultra Distance’ is defined as further than a marathon, ie over 42.2km.

Cross Country

A cross country course is designed to be appropriate for a number of races held on one day over varying distances and as such will be on a lap course that will usually be between 1,500 and 5,000 metres in length. The course will normally be suitable for spiked shoes and should not include road or other hard surfaces although it is recognised that non-championship races may include sections that make the course more suitable for studs. When an event is held under IAAF Rules then IAAF Rule 250 provides a definition of the nature of course required.

Fell and Hill

Fell Running is a traditional activity in the UK with a long history; races are held on a wide variety of courses on mountains, hills and fells. Courses are graded into categories which are defined in UKA Rules for Competition; the grading is determined by the race distance and severity of climb. Some courses may require runners to have navigational skills and many ‘A’ category races may prove hazardous and should only be attempted by those with the necessary experience to cope with the adverse conditions that may occur in remote mountain locations.

Mountain Running

Mountain Running is recognised internationally by the IAAF (via its association with the WMRA) and European Athletics. Mountain Running races take place on primarily off road terrain on well-defined routes, requiring no navigation or route choice. The profile of the course involves either considerable amounts of ascent (for mainly uphill races), or ascent/descent (for up and down races with start and finish at the same level), with no dangerous sections. The average incline of the course should be a minimum of 5% (or 50 meters per kilometre) and not exceed 20% (or 200 meters per kilometre). Runners are not allowed to use supplementary aids such as poles.

Race Walking

Race Walking is a progression of steps so taken that the walker makes contact with the ground, so that no visible (to the human eye) loss of contact occurs. The advancing leg must be straightened (i.e. not bent at the knee) from the moment of first contact with the ground until in the vertical upright position. (Rule 230(2)).

Race Walking events are held on surfaces that allow for the judging of the event. This should normally be either track or road surfaces following the requirements and standards applied to track or road running events respectively.

parkrun

Not considered races, parkrun events are free to attend, weekly, timed 5km runs. Results are presented in time order however there are no performance related prizes or medals and the first person across the line is termed the ‘first finisher’ not the winner. They may cover any reasonable surface such as tarmac, gravel paths, grass, forest trails, pavement and meadow but they do not run on public highways. Although some parkrun events will be certified as 5km, in most cases this is not guaranteed especially as courses can change from week to week in order to accommodate local conditions such as flooding or fallen trees.

parkrun events look to support rather than compete with paid races and

although runners of all abilities are welcome, the focus is on recreational running and increasing participation.

Fun Runs

Fun Runs do not usually operate under rules for competition in respect of age groups, gender and distances but an event cannot be considered to be a Fun Run if awards are made based on performance or results published with times.

Pushed Wheelchairs and Buggies

All races operated under IAAF, IPC and UKA Rules for Competition require all competitors to complete a course without assistance from any other person or source. Road Running has expanded to incorporate “Fun Runs” and fund raising activities and as such frequently generates entries from persons wishing to push a wheelchair or buggy and these entries may include entering the person being pushed as a competitor.

In such cases Competition Providers may choose to reject these entries on the understanding that the person being pushed is not completing the course without assistance. For the avoidance of doubt A person who is not contributing at all to their forward movement is unable compete (that is have a bib and their time recorded) in an athletics event.

Similarly a race risk assessment process may determine that the course or race is not safe for these entries. Note that UKA Rule 142 S1(2) allows a Competition Provider to reject an entry. Additionally UKA Public Liability Insurance is not designed to provide cover for pushed wheelchairs and buggies and any claim arising may be rejected.

GOVERNANCE AND COMPETITION PROMOTION RESPONSIBILITIES

The following table provides guidance on the role of each of the national bodies responsible for the management of Endurance disciplines and the promotion of competition. The function of management includes: regulation of competition; disciplinary issues; licensing of events; and producing fixture calendars. UKA recognises the role of a number of independent organisations in the management and regulation of competition, including the Fell Runners Association (FRA), Trail Running Association (TRA) and Race Walking Association (RWA).

	Governance	Competition Promotion
UKA	Yes	No
British Athletics	No	Yes
Athletics Northern Ireland	Yes	Yes
England Athletics	Yes	Yes
Scottish Athletics	Yes	Yes
Welsh Athletics	Yes	Yes
English Cross Country	No	Yes
English Road Running	No	Yes
runbritain	Yes	No
Fell Runners' Association	Yes	Yes
Northern Ireland MRA	No	Yes
Scottish Hill Runners	No	Yes
Scottish Hill Racing	No	Yes
Welsh Fell Runners Assn	No	Yes
Race Walking Association	Yes	Yes
Trail Running Association	Yes	Yes
UK Counties Athletic Union	No	Yes

Licensing Processes

All races in the UK are required by UKA Rules for Competition to be licensed. Licensing processes differ from discipline to discipline and the table below indicates which body you will need to make an application to. The race licence demonstrates to competitors and insurers that the race is promoted to governing body standards and that UKA Rules for Competition will apply; it does not mean that UKA public liability insurance will apply – insurance cover only applies when the organising body is affiliated to one of the four National Associations and a licence awarded to the race.

	Cross Country	Fell	Mountain	Road (inc MT)	Trail	Ultra	Walks
England	EA*	FRA	UKA	runbritain	TRA	UKA	RWA
Northern Ireland	ANI	NIMRA	NIMRA	ANI	ANI	UKA	ANI
Scotland	SA	SA	SA	SA	SA	UKA	SA
Wales	WA	WA	WA	runbritain	WA	UKA	WA

EA* Cross Country licences in England are issued by Midland Counties AA, Northern Athletics and South of England AA respectively.

Key

ANI: Athletics Northern Ireland

EA: England Athletics

FRA: Fell Runners Association

NIMRA: Northern Ireland Mountain Running Association

RWA: Race Walking Association

SA: Scottish Athletics

TRA: Trail Running Association

HEALTH AND SAFETY GUIDANCE FOR OFF TRACK ENDURANCE EVENTS

To help support the delivery of safe, enjoyable endurance activity the UKA Endurance Advisory Group has produced the following good practice guidance document for organisers of off track events (Fell, Mountain Running, Cross Country, Trail, Race Walking and Road), Club Secretaries and County Secretaries.

NB. This document sets general standards and more detailed discipline specific guidance can be found in the documents referenced at the end of this section.

Marshal Instructions:

Marshals play a hugely important part in the successful management of safe endurance events and it is critically important that all marshals are provided with details of their specific role and responsibility via a pre event briefing AND clear written instructions. Key areas that should be covered in the briefing and written instructions include:

- A map of the course/route showing – start/finish, direction runners are coming from and going to, position of first aid points, entrance and egress point of venue, access point for emergency vehicles giving either grid reference and or post code.
- A map of the course showing relevant Marshal Positions.
- A description of Marshal Positions, including street/road name and post code, grid reference or GPS coordinates as appropriate.
- The method of communication – for example: mobile telephone or two way radios (whatever systems you are using check that you have full course coverage before the event).
- Emergency contact telephone numbers and procedures to follow in the event of an incident/emergency.

Medical Provision:

Extensive medical guidance for road running events is available at <http://events.runbritain.com/rdp/>; all event organisers should provide the following information to their medical provider:

- Number of participants.
- Age Groups.
- Distance.
- Terrain – Road / Cross Country / Fell / Mountain / Trail.
- Map of the Course.
- Emergency procedures.
- Event Risk Assessment.
- Date and time of the event – Helpful for indicating types of weather you are likely to encounter.
- Any past history of accidents, incidents, hospitalisation or deaths.

Using this data, your medical provider will determine the number of personnel they recommend to support your event; what equipment they will bring; their staff qualifications and the number and type of vehicles. The provision should also take account of anticipated weather conditions. This, in effect, provides you with a medical plan that supplements your medical risk assessment.

It may be appropriate for certain events where large numbers are involved or where there is a particular risk to notify your nearest Accident & Emergency Hospital and Ambulance Trust giving details of the event and its venue, including access points (post code/grid reference). For Fell and Trail it may also be appropriate to inform Mountain Rescue or HM Coastguard.

Once the Medical Provider has been appointed you will need to agree:

- The most effective way of reacting to and reaching the casualty – medical positions spread around the course or mobile units working from a specified central position.
- The method of communication between the race organiser and medical provider.

Risk Assessment:

UKA has produced a standard risk assessment template that is to be used across all disciplines. The template, which can be found in Fact Sheet 4 at <http://events.runbritain.com/rdp/>, provides examples of the key areas that event organisers should be covering when undertaking a risk assessment.

The risk assessment is a dynamic document and needs to be compiled pre-event and regularly reviewed and updated, even on event day. When the document is updated note the amendment date or reference.

It should identify who is responsible for various actions but ultimately the event organiser owns the document and process. A risk assessment should account for specific conditions that are likely to be in place on the day of the event and must be conducted at the time your event is being staged to check on features such as shop opening times and church services. For disciplines such as Fell and Mountain Running it will be important to make an assessment of risks based upon anticipated weather conditions.

- It should include (or reference) other supporting organisations risk assessments, as described above – Medical Provision.
- The risk assessment is unique to your event.
- Whilst there is no direct legal requirement upon volunteer groups to carry out a Risk Assessment they most certainly have a duty of care to participants which (in the event of a civil claim) would require the group/ organisers to demonstrate that a suitable and sufficient assessment of risks had been carried out by a competent person; the simplest way of which would be to conduct a risk assessment.

The event risk assessment should be fully integrated with the Event Plan and available for inspection as required.

Athlete Screening:

There are times when heart disease or problems remain unknown or undetected. Many sports already use screening for funded or elite athlete programmes. Athletics would like to bring to your attention the availability of Cardio Screening through www.c-r-y.org.uk (Cardiac Risk in the Young)

Reference Documents:

This guidance document has been produced to help organisers implement the essential elements of a safe endurance event. The nature of the different disciplines of endurance running inevitably means that different events will have differing safety requirements and further details can be found in the reference documents listed below. Specific circumstances particular to Fell & Hill and Trail races may apply as a consequence of the nature of terrain used and the length of races. You should refer to the Fell and Trail sites below for further guidance and note that FRA Safety Guidelines take precedence when planning Fell and Hill races.

Road Race: Handbook and Medical Guidelines :

<https://www.runbritain.com/race-directors-club>

Cross Country Handbook & Risk Assessment::

<http://www.uka.org.uk/competitions/useful-documents/>

Fell Running: Safety Requirements, Organisers Safety Checklist and Guidelines for Organisers:

<http://fellrunner.org.uk/organisers.php>

Trail Running: <https://www.tra-uk.org/organisers>

Race Walking: apply road running standards.

ROAD RUNNING

The Event Adjudicator

An Event Adjudicator must be appointed for all Road and Multi Terrain races licensed by runbritain. Where a race series is staged at the same venue over the same course then only one race will need to be covered unless there are concerns raised within the Event Adjudicator's Report. The Event Adjudicator is responsible for assessing whether the Race Organiser delivers the event to runbritain Licence Standards. The Event Adjudicator reports to the Regional Panels and should issues be raised these are flagged for action. Subsequent licence applications by the race or race organiser cannot be considered until the Chair of the Regional Panel is satisfied that all issues have been addressed and resolved.

Experience and Knowledge requirements:

- Current Endurance Official (Level 2)
- BARR Scrutineer (BARR to identify and provide list)
- Current Race Promoters
- A good knowledge of Race Organisation
- Understanding of Risk Assessment
- A good communicator
- Awareness of Road Race Licence Standards
- Able to pass an online test if there are any concerns about an applicant's level of competence
- A buddy system operates for when undertaking their first event.

The Event Adjudicator will:

- Be covered by UKA Public Liability Insurance
- Be issued with Accreditation, access code to Race Director Portal and URL Number*
- Be DBS Checked
- Submit the report online within 7 days of the race

*This will need to be quoted by Race Promoters on application for a Licence. It will also provide access to complete Race Reviews online.

It will be The Event Adjudicator's role to:

- Undertake the review and make comment of the current "Checklist" against Licence Standards
- Understand the demands on the Race Promoters on race day and not to be a burden on this role
- Communicate with the Race Promoter pre and post event as well as on event day
- Offer advice, if sought, in a constructive manner

Note: For smaller races (entries less than 300) the role of the Event Adjudicator and Race Referee can be undertaken by the same person provided they hold the appropriate Endurance Official's qualification and feel able to undertake both roles.

Role of Regional Panel

- Review Event Adjudicator's Report
- Review standards of Event Adjudicator Reports
- Make recommendations to Race Promoter and runbritain for agreement and implementation of recommendations prior to issue of Licence to his/ her next event.
- Emphasis should be given to areas such as:
 - Was start / finish traffic free?
 - Was there a risk assessment undertaken and available?
 - Was the measured course run on the day?

Regional Panel Chair's Role

- Liaise with the Race Promoter for feedback
- Implement flagging on the system where agreement can't be reached with the Race Promoter and concerns continue to stop automatic approval of future licences. Any restrictions on future licences must cover the individual, the race and organisation to cover all eventualities.
- Liaise with runbritain
- Ensure reports and close outs are undertaken in a timely manner

Competition Provider/Race Organiser

The Race Organiser has overall responsibility for the event. All pre-event, event day and post event decisions will be under his or her jurisdiction.

Pre-Event Planning will cover;

- The management structure and delivery mechanism
- Obtaining UKA Road Race Licence and Course Measurement Certificate (if required)
- Consultation and agreements with landowners, local authorities, safety advisory group, emergency services, the community, engagement of contractors, appointing medical services, obtaining consents, obtaining licenses if required, provision of event infrastructure
- Undertaking written risk assessments

Race Referee

Appointment: the Referee and all other officials are appointed by the Race Organiser

The Race Referee is responsible for ensuring that UKA and any local rules of competition are interpreted and implemented in a fair manner. He / she may assist the Race Organiser to provide sufficient endurance officials (or volunteers) to cover timing and time recording, judge / recorders, funnel controllers and other duties that may be required.

- Receive any objections/appeals regarding published results
- If published at the event – Appeal to be lodged at the event
- If published after the event – Appeal, via The Race Organiser, to be lodged within 14 days of the results being published
- The Race Referee will receive a copy of the entry list, to include late entries
- In road relays no changes may be made in the declared order of running without the prior approval of the Race Referee and the Promoter

- The Race Referee may disqualify any runner who does not follow the correct course or obey the instructions of Police or race officials
- The Race Referee should verify results before they are published

Endurance Officials, including those qualified to referee, can be identified and contacted through the appropriate County Officials Secretary.

COMPETITION ISSUES

Additional Gender Categories

Competition Providers promoting road races may offer a third non binary gender option within their events. Such an approach will be piloted from 2018. For ranking purposes, only Male and Female gender categories will be recognised.

Use of Audio Headsets and Mobile Telephones by Runners

IAAF Competition Rules do not permit the use of any form of audio headset or mobile telephone within the competition area (which includes road and cross country races). From April 2016 UKA Rules for Competition do not allow the use of headsets in any road race that is held on single carriageway roads that are open to traffic. (Rule 240 S5).

The advice to race promoters is that their race risk assessment should take account of the possibility of runners wearing headsets or using telephones and apply local conditions appropriate to the findings of the risk assessment. If it is deemed unsafe then promoters may restrict use and disqualify any runner found to be contravening the instruction. UKA will support any race promoter taking such action.

Races in which audio headsets and mobile telephones should not be used include:

- Championships
- Cross Country

- On roads that are open to traffic
- On lap courses – including when closed to traffic
- Where runners must be alert to marshals' instructions

Guidance for Distances Appropriate for Young Runners

UKA have clear rules (Rule 141) on the maximum race distances that are recommended for young athletes. These are in place to ensure that the health and wellbeing of the young person is paramount and that good practice in developing athletic skill and ability is followed. The best place to seek advice on running distances and training methods is through a local running club or group with qualified coaches and/or leaders. UKA recognises that some young people may participate in a race over a distance longer than that stated in the rules/guidance for purposes of a charity run or something similar. A one off race completed over distance is unlikely to be a problem for a young person but repeated runs are not recommended.

Running with Dogs

Dogs are not allowed in any licensed competition unless a special exemption has been granted to a runner accompanied by a medical assistance dog. Runners in parkruns are allowed to run with one dog but it must be under close control.

TECHNICAL OFFICIALS (ENDURANCE)

An education and training process has been developed to assist Technical Officials who wish to work at endurance events to progress through the structure whilst acknowledging that many will want to achieve the basic level of qualification to help at their local club events. The process is managed at a policy level by the UKA Endurance Education and Development Sub-Group which is responsible to the UKA Technical Advisory Group. Delivery of courses is managed by the four National Associations.

The responsibility for the accreditation and upgrading of Endurance Officials up to Level 3 is delegated to six administrative areas within the UK: Northern Ireland, Scotland and Wales and three areas in England.

The three Tri-Regional groupings for England are the Northern group (North-East, North-West and Yorkshire and Humberside), the Southern Group (East, London and South East) and the Midlands and South Western Group (East Midlands, West Midlands and South West).

Accreditation of Endurance Officials to Level 4 and above is managed by the UKA Endurance Education and Development Sub-Group, and where appropriate, making recommendations for selection for major national meetings.

The range of duties incorporated in Endurance officiating includes: referee, line judge, funnel judge and recorder, timekeeper recorder, funnel control, chip management, clerk of the course (cross country), marshal, start management and lap recording. Qualification as a Starter and Timekeeper is managed through the track and field officials' process as the duties are deemed to be similar.

All qualified Technical Officials must hold a current DBS certificate and receive a pass and licence that recognises their level of qualification. Licences must be renewed every three years by updating the DBS certificate.

Any changes to the process during the lifetime of the Rule Book will be published on the British Athletics website in Competitions / Officials / Endurance Officials. Details of planned courses may be obtained from your National Association.

Endurance Officials' Pathway

The Endurance Officials' Pathway describes the process and requirements for progressing from Level 1 to Level 5 International Official; the effective level for operating at major domestic competitions in the UK is Level 4 and Level 4 Officials fill the majority of appointments in international races held in the UK.

The Pathway diagram, and other guidance documents, can be found at <http://www.uka.org.uk/competitions/officials/endurance-officials/> along with the record of experience form and the Health and Safety Guidance leaflet.

Getting started

Having decided that you want to be involved in endurance events in an official capacity, contact should be made with your local club(s) and/or event organisers. Your initial involvement may be at what you might consider to be a basic level, for example, as a marshal. For those interested or who may develop an interest in being involved in a wider or at a higher level, the Endurance Officials' Pathway for development and licensing is described below. More comprehensive guidance can be found in the booklet "Getting Started as an Endurance Official" which can be found at: <https://www.englandathletics.org/officials> or through the appropriate National Association.

Level 1: Endurance Official

For those with some experience of working at events and / or for those who wish to continue along the Endurance Officials Pathway, attendance at a Level 1 Endurance Officials' Course is essential. The Level 1 Endurance Officials course is a half day classroom based tutored course. In addition to attending a course it will be necessary to complete four separate competition experiences showing evidence of carrying out various roles and responsibilities. The experiences include course marshalling, stewarding, recording or assisting at the start or finish.

You should record your experiences, on an Annual Record of Experience (RoE) form, as these will need to be included in your Application for Accreditation as a Level 1 Endurance Official. You should aim to record these experiences immediately after an event. After completing the required number and type of experiences, submitting a UKA Application for Accreditation form as a Level 1 Endurance Official and completing a Disclosure and Barring (DBS) check you will then be eligible to be licensed as a Level 1 Endurance Official.

The RoE should be submitted annually to your National Associations' Officials Administrator.

Level 2: Endurance Official

If you wish to progress to the next level, as a Level 2 Endurance Official, you will need to complete an additional six competition experiences and study three of the following Level 2 Modules:

- Race Referee
- Judging and Recording
- Race Director
- Start Director
- Finish Director
- Sector Marshal

If you are looking to referee at local / club races you must complete the Race Referee module at this stage together with the Risk Awareness course (see below). You should also submit a UKA Application Form for Accreditation as a Level 2 Endurance Official. When licensed as a Level 2 Official you can referee local / club road races typically up to 600 runners and cross country races up to 300 runners.

Level 3: Endurance Official

The next level of progression requires completion of an additional ten Competition Experiences detailed on a Level 3 Application for Accreditation, the obtaining of one positive report on how you performed your duties, together with completion of the remaining three Level 2 Course Modules (see above). After satisfactory submission of UKA Application Form for Accreditation as a Level 3 Endurance Official you would then become licensed as a Level 3 Official. This would enable you to referee regional races (or home country equivalent) typically up to 3,000 runners in a Road Race or 300-400 in a Cross Country race.

For these higher levels, relevant experience includes being the Clerk to the Course, Course Director, managing a sector such as the start or finish or group of marshals, lap recording, setting up the course or, for County and smaller races, acting as the referee.

Level 4: Endurance Official

The UK Athletics Level 4 is a progression from Level 3 that both consolidates learning at Level 3 and prepares the official to operate at national and international level through the introduction of additional modules including meeting management.

Detailed guidelines for applicants for Level 4 are on the UKA website at <http://www.uka.org.uk/competitions/officials/endurance-officials/>

To achieve Level 4 officials must:

- Attend a generic workshop delivered by an approved tutor
- Complete a logbook.
- Work with an appropriate mentor
- Submit logbook for assessment and undergo assessment of competence and knowledge and understanding of UKA and IAAF rules and the differences between them by an approved assessor.

Duplication of reports is not acceptable in any circumstance other than as described below where one report can be carried forward from a Level 3 application. To achieve progression to Level 4 positive reports on all the following duties are essential:

- Referee or Assistant Referee
- Start Area Coordinator / Start Director
- Finish Area Coordinator / Finish Director
- Clerk of Course / Course Director

All reports assessing an Official's competency to perform at level 4 must be completed by accredited Level 4 Officials who have been at that Level for at least 2 years.

Reports must be submitted by at least 2 different accredited officials, and the annual record of experience forms needs to show at least 20 experiences as a Technical Official over a designated period of time (as

a guide this would normally mean a minimum of 3 years) across a number of County, Regional and National races in varying roles and should include evidence of at least 12 experiences in senior positions.

If the meetings are all local meetings the candidate is unlikely to have sufficient experience to move straight to Level 4 and if they have not travelled out of their local area this may show a limited commitment to travel. It is important that the candidate carries out the full range of duties relevant to their discipline.

All candidates must include sufficient detail on their Record of Experience so that it is clear which duties they have carried out. Experience of refereeing at a local level event is essential for progression to Level 4.

Tri-Regional Peer Groups will review applications for progression to Level 4 annually in September / October of each year. The outcomes of the application will be communicated to applicants in January following the meeting and decisions of the UKA Endurance Education and Training Sub-group.

The National Endurance Peer Group requires evidence of competence to make a sound decision. Reports must be obtained from both road racing and cross-country races; however, there is no specific ratio of how many are required from each.

The positive report submitted for accreditation at Level 3 must demonstrate managerial experience and can be used as one of the 4 reports required for accreditation to Level 4 if it is less than 3 years old at the time the application for accreditation is made.

Officials who have satisfied the requirements of the Level 4 accreditation system will be listed as Level 4P for two years after qualification but will immediately become eligible to receive information regarding selection for national and international competitions under the auspices of UKA. This is a probationary period during which positive assessments are required for the Official to remain eligible for consideration for selection for such competitions. Should such assessments not be received the

official will retain their Level 4 designation but will no longer be eligible for selections as mentioned above.

The Level 4 qualification recognises all Technical Officials at that level as National Technical Officials, equivalent to Level 1 officials under the IAAF TOECS (Technical Officials Education & Certification System).

Any Level 4 official who has not submitted their records of experience and availability forms for a period of three years will be considered to be inactive at National level and will no longer receive availability requests. They may apply for re-instatement through their TRNG.

Risk Awareness Course

All Endurance Officials must attend the Risk Awareness module – a half day course, usually held in conjunction with the Level 1 course, to qualify as an Endurance Official. Acknowledging that you have read and understand the Health and Safety Guidance Leaflet should be recorded in your log book.

The ultimate responsibility for risk assessment at road races rests with the Race Director but Race Officials should be aware of all implications should the need arise.

INDEX OF TECHNICAL RULES

	<i>RULES</i>
A	
ABBREVIATIONS (START LISTS, RESULTS)	132.4
ABSENCE DURING COMPETITION	180.19
ACCIDENTS - PRECAUTIONS: SEE SAFETY	
ADHESIVE TAPE	170.4; 180.3(a), 182
ADVERTISING – INTERNATIONAL COMPETITIONS	8
ADVERTISING AND SPONSORSHIP – UKA	8 S1; 143 S1
AGE CATEGORIES	
Masters	141.1
Minimum ages	141.1 (Note ii)
U18	141.1
U20	141.1
AGE GROUPS: UKA	141 S1
Cross Country and Road	141 S3
Fell, Hill and Mountain Running	141 S4
Track & Field and Race Walking	141 S2
Trail Running	141 S5
AMALGAMATION OF CLUBS	21 S2 (12)
ANNOUNCER – DUTIES	120; Appendix 3
ANTI-DOPING UKA: CLEAN ATHLETICS	30 S1
APPEALS – SEE PROTESTS & APPEALS	
AREA TECHNICAL OFFICIALS (ATOS)	
Appointment	110
Duties	115
ASSISTANCE	
Cross-Country	250.7
Field Events	
Bandage at the wrist	144.4(c)
Belt for support	144.4(c)
Elbow protection	144.4(c)
Gloves	187.4(c)
Knee support	144.4(c)
Taping of fingers and hand	187.4(a); 187.5(c)
Throwing Events	187.4-5
Use of substances	187.4(d); 187.5(a)
Wind sock	180.4(b)
General	
Advice	144.3(e)
Appliance	144.3(c)
Communication	144.4(a)
Mechanical aid	144.3(d)
Medical	144.1; 144.4(b)

Mobile phones	144.3(b)
Personal electronic equipment	144.4(d)
Personal safeguards	144.4(c)
Shoes	143.2; 143.6
Technical device	144.3(a)
Race Walking	230.10
Track Events	
Drinking and sponging	163.15
Intermediate times	163.14
Pacing	144.3(a)
Receiving Physical Support	144.3(f)
ATHLETE BIBS	143.7-9
Perforations	143.8
Worn as issued	143.8
Road Races	143 S2
ATHLETE REPRESENTATIVES	7 S1
B	
BANKING (INDOOR EVENTS)	
Angle	213.3
Finish line in relation to banking	214.7
High Jump approach from banking	219.2
Horizontal Jumps approach from banking	221
Pole Vault approach from banking	220
Start position in relation to banking	214.7
BATON	
Dimensions	170.5
Dropping the baton	170.6
Position in relation to takeover zone	170.7
Starter's Assistant's responsibility	162.5; Appendix 3
BELL	Appendix 3
BETTING	60 S1
BIBS – SEE ATHLETE BIBS	
BLOCKS – SEE STARTING BLOCKS	
BONA FIDE EFFORT – SEE ALSO	142.4(c); 163.2; 260.1
DISQUALIFICATION	
BREAK LINE	
Dimensions	163.5
For 800m and appropriate relays	163.5; 170.13-16
For starts split into two groups	162.10
Indoor provision	214.6
Use of cones to indicate line	163.5
C	
CAGES	
Discus	190
Hammer	192; 192 S1-2
Joint hammer and discus	192.6

CALIBRATED BICYCLE	
Method intended for measuring road courses	240.3 (Note (i), (ii))
CALL ROOM	
Call Room Referee	125.5
Failure to report	142.5
Medical Assistance after leaving	144
Relay Team Declaration	170.11
UKA Technical Officials	Appendix 3
CARTWHEELING TECHNIQUE – SEE SHOT PUT	
CAUTION – SEE WARNINGS AND DISQUALIFICATION	
CENTRALISED LANDING AREA	184.6 (Note)
CERTIFICATION	
Implements	187.1-3
Road Race Courses	240.3
Tracks	140
CHANGE OF COMPETITION AREA OR TIME	180.20
CHECK MARKS	
Field Events	180.3
Relay	170.4
Track events other than Relay	163 (7)
CLERK OF THE COURSE – DUTIES	Appendices 3-4
CLOTHING	
General regulations (including Indoors)	143.1
CLOTHING: UKA COMPETITION	
Lettering and Logos	143 S1
Race Walking Conditions	143 S1
Track and Field Footwear	143 S1
COLLEGES – SEE ELIGIBILITY TO COMPETE	
COMBINED EVENTS	
Age Groups Younger than IAAF Age Groups	200 S1
British Records	264 S1
Competing order	200.7
Conditions for Records	260.8; 260.18
Decathlon Event Order	
U18 Boys, U20 & Senior Men	200.2
U20 & Senior Women	200.2
Delay a trial	180.18
Failure to attempt to start	200.10
False start	162.7; 200.8(c)
Height progression	200.8(d)
Heptathlon Event Order	
Indoors	223.3
Outdoors	200.3; 200.5
Indoors	223
Number of trials	200.8(a)
Pentathlon Event Order	

Indoors	223.1; 223.3
Outdoors	200.1
Referee	200.6-7; 200.10
Rest interval between events	200.6
Scoring	200.11
Ties in final classification	200.12
Timing	200.8(b); 200.9
COMPETING ORDER – FIELD EVENTS	
Initial order	180.5
Order for the last three rounds of trials	180.6
Qualifying round	180.5
UKA Field Events	180 S2
COMPETITION DIRECTOR – DUTIES	145.2
COMPETITION YEAR	21 S6; 141 S1-3
COMPOSITE TEAMS	21 S4; 21 S8
COUNTY QUALIFICATIONS – SEE ELIGIBILITY TO COMPETE	
CROSSBARS	181.7
CROSS-COUNTRY	250
Course design	250.1-3
Disqualification	250.9
Distances	250.4
Drinking / sponging and refreshment stations	250.8
Headphones: UKA Races	250 S2
Relays	250.5
Safety	250.7
Start	250.6; 250 S1
Transponder timing	165.24
UKA Race entry qualifications	250 S2
Venue	250.1
CROSS-COUNTRY, UK - SEE ALSO ENDURANCE RUNNING UKA	Appendix 4
D	
DECATHLON – SEE COMBINED EVENTS	
DISABILITY – ATHLETES WITH A	125.8; IPC Rules; Appendix 2
DISCUS THROW	
Assistance	187.4-5
Cage	190
Circle	187.6-8; 187 S3
Circle (Leaving)	187.17(a)
Danger sector	190.5
Failure	187.14(b); 187.15-17
General conditions	187
Implement details	189.1-2
Implement details: Non-IAAF age groups	189 S1
Landing sector	187.10-12
Measurement of trial	187.19-20

DISQUALIFICATION FROM COMPETITION	
Assistance	144.2
Combined Events	200.8(c); 200.10
Cross-Country	250.8
Identification of infringement in results	142.4 c); 145
Offensive language	145 S1 (2) and Note
Unsporting or improper manner / conduct	125.5; 145.2; 162.5
Race Walking	230.7; 230.10(h); 230.13
Track Events	
Bona fide effort	142.4(c); 163.2
False start	162.7
Hurdles	168.7
Lane infringement	163.3
Obstruction	163.2
Relay	170.6-11; 170.18-21
Steeplechase	169.7
DOPING CONTROL DELEGATE - DUTIES	110
DRAW	
Combined Events	200.7
Field Events	180.5-6
Track Events	
Indoors	215.2-3
Outdoors	166.2-6; 166.5
DRINKING / SPONGING AND REFRESHMENT STATIONS	
Cross-Country	250.7
Race Walking	230.10
Road Races	240.8
Track Events	163.15
ELECTRONIC DISTANCE MEASUREMENT	148.2
ELIGIBILITY TO COMPETE	21 S1
Clubs	21 S2
Club Membership	21 S3
Competition Conditions	21 S4
Composite Teams	21 S4
County, District and Area Qualifications	21 S6
Eligibility and Exemption Applications	21 S8
First Claim Status	21 S5
Foreign Athletes	21 S5
Higher Competition Clubs and Members	21 S3
Home Country Qualifications	21 S7
Ineligibility to Compete	23 S1
Online Eligibility Transfer Process	21 S3
Open Team Competition	21 S9
Other Discipline Membership	21 S5
Registration with National Association	21 S1
ENDURANCE RUNNING: UKA	
Disciplines	Appendix 4

Endurance Technical Officials	Appendix 4
Governance and Competition Responsibilities	Appendix 4
Health and Safety Guidance	Appendix 4
Licensing Processes	Appendix 4
Road Running Guidance	Appendix 4
ENTRIES	
Eligibility	142
Simultaneous entries	142.3
ENTRIES: UKA COMPETITION	
Fell, Hill and Mountain Running	142 S3
Road Races	142 S2
Trail Races	142 S4
F	
FAILURE	
Jumps	180.18
High Jump	181.2; 182.1; 182.2
Long Jump	185.1
Pole Vault	181.2; 183.2; 183.4
Triple Jump	185.1; 186.2
Throws	180.18
Discus	187.14(b); 187.16-17
Hammer	187.14(b); 187.16-17
Javelin	187.14(a)(d); 187.16-17; 193.1-2
Shot	187.14(a)(b)(c); 187.16-17
To participate	142.4
FALSE START – SEE START	
FELL AND HILL RUNNING: UKA	
Race Categories	251 S1
Race Distances	251 S1
Safety	251 S1
FIELD EVENTS – GENERAL CONDITIONS	180
Absence during Competition	180.19; UKA Note
British Records	264 S1
Markers	180.3
Practice Trials	180.1-2; 180 S1
Qualification Round	180.9
Ties	180.22
Trials – see Trials recorded (Field Events)	
FIELD JUDGE - DUTIES	Appendix 3
FIRST CLAIM – SEE ELIGIBILITY TO COMPETE	
FINISH LINE	164.1-2
FINISH OF RACE	164.1-2
FIXED TIME RACES	164.3
FOOTWEAR – SEE SHOES	
FULLY AUTOMATIC TIMING – SEE PHOTO FINISH	
G	

GLOVES	170.6(b); 187.4(c)
GRADED COMPETITIONS	141 S2; 147 S1
GREEN CARD	162.5, 162.8(Note)
H	
HAMMER THROW	
Assistance	187.4-5
Cage	192
Cage: UKA	192 S1
Cage Gate Panels: UKA	192 S2
Circle	187.6-8; 187 S3
Leaving	187.17(a)
Danger sector	192.7
Failure	187.14(b); 187.16-17; 191.2-3
General conditions	187
Gloves	187.4(c)
Implement details	191.4-8
Implement details: non IAAF Age Groups	191 S1
Landing sector	187.10-12
Measurement of trial	187.19-20
HAND TIMING	165.1-12
HEATS – SEE ALSO DRAW	166.1-8
TIME INTERVAL BETWEEN ROUNDS	166.9
HEPTATHLON - SEE ALSO COMBINED EVENTS	200.3; 200.5; 223.2
HIGH JUMP	
Crossbar specifications	181.7; 182.9
Crossbar support	182.8
Elasticity of crossbar control	181.7
End pieces	181.7
Extraneous forces	181.10
Failure	182.2
Height progression	181.4
Height progression – Combined Events	200.8 (d)
Indoors	219
Landing area	182.10
Measurement of height	181.5-6
Number of trials	181.2-4
Runway	
Inclination	182.4
Indoors	219
Length	182.3
Take off	182.5
Ties	181.8
UKA Landing Area	182 S1
Uprights	182.6; 182.7
HIGHER COMPETITION CLUBS AND MEMBERSHIP	21 S3-4; 21 S8
HORIZONTAL JUMPS	184; 185; 186

HURDLES

Construction	168.2; 168.5
Counterweights	168.2
Dimensions	168.3
Disqualification	168.7
Distances and specifications	168.1
Distances and specifications – Non-IAAF Age Groups	168 S1
Indoors	217
Lane running	168.6-7
Positioning on track	168.1
World Record	168.8-9

I**IMPLEMENTS – SEE OFFICIAL IMPLEMENTS**

INDOOR STADIUM	211
-----------------------	-----

INTERNATIONAL CROSS-COUNTRY, ROAD RUNNING, MOUNTAIN RUNNING AND TRAIL RUNNING OFFICIALS (ICROS)

Duties	115
Selection	110

INTERNATIONAL PHOTO FINISH JUDGE

Duties	165.20(Note)
Selection	110

INTERNATIONAL RACE WALKING JUDGES

SELECTION	110
------------------	-----

INTERNATIONAL ROAD RACE MEASURER	110
---	-----

SELECTION

INTERNATIONAL STARTER SELECTION	110
--	-----

INTERNATIONAL TECHNICAL OFFICIALS (ITOS)	110
---	-----

SELECTION**J****JAVELIN THROW**

Assistance	187.4-5187.4-5
Failure	187.14(a)(d); 187.16-17; 193.1-2
Implement details	193.3-11
Implement details: non IAAF Age Groups	193 S1
Landing sector	187.10-12
Measurement	187.19-20
Runway	187.9
Leaving	187.17(b)
Unorthodox technique	193.1(a)
Valid throw	193.1

JUDGES – SEE OFFICIALS OF THE COMPETITION**JUNIOR MEN AND WOMEN – SEE AGE GROUPS UKA****JURY OF APPEAL**

Duties	110; 146.1; 146.7-10
Selection	110

K	
KERB	
Indoors	213.1; 213.4(Note)
Measuring track length	160.1-3
Replaced by cones	160.1
UKA Track Measurements	160 S1
L	
LANE DRAW – SEE SEEDING OF TRACK EVENTS	
LANE	
S	
Infringement	163.3-5
UKA: Running on the line	163 S1
Number of lanes	160.5
Width	
Indoors	212.2; 213.2
Outdoors	160.4
LAP SCORERS	Appendix 3
LEAGUES	21 S4; 141 S2
LEAVING THE COMPETITION AREA IN FIELD EVENTS	180.19
LEAVING THE TRACK OR COURSE	163.6; 240.9
LICENCE	
Coach	21 S3
Competition	
Cross-Country	2 S2; Appendix 4
Road Race	2 S2; 142 S2; 240 S1; Appendix 4
Trail Race	2 S2
Track & Field	2 S2; Appendix 2
Official	21 S3; 230 S1;
LOCATION CHANGE IN FIELD EVENTS	180.20
LONG JUMP	
Failures	185.1
Indoors	221
Landing area	184.6-7
Leaving	185.1(f); 185.2
Measurement of jump	184.8-9
Plasticine indicator board	184.3; 184.5; 185.1(a)
Runway	184.1-2
Take-off board	184.3-4
Take-off line	185.3-4
Wind measurement	184.10-12
M	
MARKERS	
Field Events	180.3
Lane	162.8
Performance	180.4

MARKSMEN – SEE STARTER’S ASSISTANTS	
MASTERS	
Definition / General	141.1; 141 S2-3
Discus Specifications	189 S1
False Start - UKA	162 S1
Hammer Specifications	191 S1
Hurdle Specifications	168 S1
Javelin Specifications	193 S1
Shot Specifications	188 S1
Steeplechase	169 S1
MEASUREMENTS	148; 160; 181.5-6; 184.8-9; 187.19-20
MEDICAL DELEGATE	110; 144.1(b)
MEDICAL EXAMINATION	144.1; 144.4(b)
MEDICAL STAFF – SEE OFFICIAL MEDICAL STAFF	
MEETING MANAGER DUTIES	120; Appendix 2; Appendix 3
MEMBERSHIP OF A CLUB – SEE ELIGIBILITY TO COMPETE	
MISCONDUCT	60 S1; 142 S1; 145 S1; 146 S1
MIXED COMPETITION	147; 260.1
MIXED COMPETITION – UKA COMPETITION	147 S1
MOUNTAIN RACES	251
Course	251.1
Drink and refreshment stations	251.5
Race conduct	251.6
Safety	251.4
Start	251.3
Types of races	251.2
N	
NATIONAL TECHNICAL DELEGATE	Appendix 3
NEUTRAL ATHLETES	4.1; 4.2; 5
NUMBER CARDS – SEE ATHLETE BIBS	
O	
OBSTRUCTION	
Relay	170.10; 170.15
Track Events	163.2
OFFICIAL IMPLEMENTS – THROWING EVENTS	187.1-2
OFFICIAL IMPLEMENTS: NON-IAAF AGE GROUPS	188 S1; 189 S1; 191 S1; 193 S1
OFFICIAL MEDICAL STAFF	144.1; 144.4(b)
OFFICIAL TIME	
Cross-Country	165.24
Road Races	165.24

Track Races	165.1; 165.8-9; 165.11-12; 165.22-23
OFFICIALS OF THE COMPETITION	120; Appendix 3
OPEN TEAM COMPETITION	21 S3-4; 21 S9
ORAL PROTEST	146.4
ORGANISATIONAL DELEGATE - DUTIES	111
OTHER RECORDS	265
P	
PARTICIPATION "UNDER PROTEST"	146.1; 146.4(a); 146.5
PENTATHLON – SEE COMBINED EVENTS	
PERMISSION TO PROMOTE	2 S1
PHOTO FINISH	
Alignment of the camera	165.15
Accuracy and certification	165.14-18
Chief Photo Finish Judge	
Duties	165.19; 165.21, 167
Liaison with other officials	165.19
Role in resolving ties	167
International Photo Finish Judge	110; 118; 165.20(Note)
Numbers on shorts	143.9
Number of cameras	165.20
Official times	165.22
Photo Finish Judges - duties	165.21-23
Reading and recording times	
Races up to 10,000m	165.23(a)
Races over 10,000m	165.23(b)
Races out of stadium	165.23(c)
Requirements of the System	165.14-18; 165.20; 165.22
UKA Records	264 S1
Zero control operation	165.19
Zero control test for Records	260.7(c); 260.14(a)
PERMISSION TO PROMOTE	2 S1
PERMITS / LICENCES (ALL DISCIPLINES)	2 S2
PLACE OF COMPETITION - CHANGE	180.20
PLASTICINE INDICATOR BOARD – SEE LONG JUMP	183
POLE VAULT	
Box	183.8
Crossbar	
Movement	183.1
Specification	181.7
Support	183.10
Distance markers	180.3(c)
Failure	183.2
Height progression	181.4
Height progression, Combined Events	200.8 (d)

Indoors	220
Landing area	183.12
Measurement of height	181.5-6
Number of trials	181.2-4
Pole	
Break during vault	183.5
Construction	183.11
Falling towards bar	183.4
Taping	183.11
Protection against injury	144.4(c); 183.10(Note)
Runway	
Inclination	183.7
Length	183.6
Uprights	183.9
Use of substances	183.3
PRACTICE TRIALS AT COMPETITION AREA	180.1-2; 180 S1
PROGRAMMES AND PRINTED MATERIAL	2 S1; 142 S1
PROTESTS AND APPEALS	
Competing "under protest"	146.1, 146.4(a) 146.5
Cost of an appeal (deposit)	146.7
Eligibility to compete	146.1
Jury of Appeal	110; 146.1; 146.7-10
Meetings with no Jury of Appeal or TIC	146 S1
Oral Protest	146.4-5; 184.9; 187.20
Procedures	146.2-6
Right of appeal	146.4; 146.10
Start	146.4
Time limits	146.2; 146.7
Q	
QUALIFYING COMPETITION - FIELD EVENTS	180.9-16
QUALIFYING STANDARDS	180.12-15
R	
RACE WALKING	230
Chief Judge	230.4
Definition of Walking	230.2
Disqualification	230.7
Drinking / sponging and refreshment stations	230.10
Judging	230.3
Judging – UKA Officials	230 S1
Open Roads – UKA Safety Conditions	230 S2
Pit Lane	230.7(c)
Posting Board	230.4(c); 230.7(e)-f)
Recorder	230.4(c); 230.7(e)-f)
Red Paddle / Red Cards	230.4(a); 230.6; 230.7
Road courses	230.11
Safety	230.8
Transponder Timing	165.24

World Records	260.14-15; 260.19-20
Yellow paddle	230.5
REACTION TIME	161.2
RECORDS	
World Records	260; 261
Combined Events	260.18
Field Events	260.17
Indoors	260.13; 263, 264
Race Walking	260.14; 260.19; 260.20
Relay	260.3(d); 260.16
Road	260.21
Track	260.12; 260.14
U20	260.2(b)(d); 260.3(c); 262; 264
Other Records	265
British Records	264 S1
RED CARD – REFEREE	125.5
REFEREES	
Appointment and duties	125; Appendix 3
Combined Events	200.6-7; 200.10
Disqualifications / Protests – duties	125.5; 142.4; 145 S1; 146.3; 163.2
REFRESHMENTS	
Cross-Country	250.7
Race Walking	230.10
Road Races	240.8
Track Events	163.15
RELAY RACES	
Baton	170.5-7; 170 S1(1)
Check marks	170.4
Indoor events	218; 214.5; 218.1; 218.4; 240.5
Infringements	170.6-11; 170.18-21
Medley Relay	170.14; 170.18; 170.20-21
Relay Records	260.3(d); 260.16
Takeover zone	170.3; 170.7; 170.19
Team membership	170.10-11
UKA Races – 4x300m	170 S1(2)
RESIGNATION FROM CLUB	21 S3
REST PERIODS	166.10; 166 S1; 200.6; 200 S1
RESULTS	
Announcing	146
Field Events	180.21
Official time – hand timing	165.12
Signing of result cards	125.4; 264 S1.13
System	165.21

ROAD RACES	240
Additional Gender Categories - UK	Appendix 4
Course design, UKA	240 S1
Course measurement	240.3
Drinks and refreshment stations	240.8; 240 S2
Headphones	240 S5
Race classification, UKA	240 S3
Records	260.21
Relays – see Road Relays	
Running with dogs	240 S6
Safety	230 S2; 240.7; Appendix 4
Standard distances	240.1; 240.2 (Note(i))
Start	240.6
Transponder Timing	165.24
UKA course measurement certificate validity	230.3 UKA Note
ROAD RACES UK – SEE ALSO ENDURANCE	Appendix 4
RUNNING UKA	
ROAD RELAYS	
Distances, stages	240.1(Note(i)); 260.21(g)
Records	260.21
Restriction on entry numbers - UKA	240.S3
S	
SAFETY	
Cross-Country	100; 240.7; Appendix 4
Mountain races	100; 142 S2; 251.4; 251 S1; Appendix 4
Road Racing	100; 2 S2 (4); Appendix 4
Track & Field	100; 120 Note; 187 S2; 21 S4 (7);
Trail Races	100; 252.4-5; 252 S2; Appendix 4
SCHOOLS	2 S1; 21 S5; 162 S1
SCORING OF MATCHES	151
SECOND CLAIM STATUS	21 S3-4; 21 S6
SEEDING OF TRACK EVENTS	
Indoors	215.1
Minimum times between rounds	166.10; 166 S1
One Day Meetings	166.9
Outdoors	166.3
SERVICES (HM)	2 S1; 240 S3
SEX CATEGORIES	141.3-6; Appendix 4
SHOES	
Construction	143.2; 143.5-6
Dimension of spikes	

Indoors	215
Outdoors	143.4
Number of spikes	143.3
Shoe strap	143.2
SHOT PUT	
Assistance	187.4-5
Cartwheeling technique	188.1(Note)
Circle	187.6-8
Circle - Leaving	187.17(a)
Failure	187.14(a)(b)(c); 187.16-17
General conditions	187
Indoors	222
Implement details	188.4-5
Implement details: non IAAF Age Groups	188 S1
Landing sector	187.10-12
Measurement of trial	187.19-20
Stop board	188.2-3
Valid put	188.1
SPIKES - SEE SHOES	
SPONGING	163.15; 230.10; 240.8; 250.7
START	
Aborting	162.5
Commands	162.2
Cross-Country	250.5
Delay in responding to commands	162.5(b)
False start	162.6-9
Language of commands	162.2
Protests	146.4
Race Walk	230.8
Reaction time	161.2
Road Races	240.6
Split start	162.10
Start line	162.1
Under 13, Under 15 and Masters' and Schools' Under 17 Age Groups	162 S1
STARTER AND RECALLERS – DUTIES	162.3-5; 164.3
STARTER'S ASSISTANTS – DUTIES	162.5; 162.8
STARTING BLOCKS	
Construction	161.1
Foot contact with blocks	162.3
Positioning within lane	161.1
Reaction time	161.2
Restriction of use	161.1
Start Information System	161.2; 162.6(Note)
Starting Blocks: UKA	161 S1
STEEPLECHASE	
Distances	169.1; 169.4

Infringements	169.7
Specification and placing of Hurdles	169.2-3; 169.5; 169.5(Note)
Water Jump	169.2-3; 169.5-7
Clearance	169.7
Dimensions	169.6
Disqualification	169.7
Number	169.2-3
Steeplechase: UKA Age Groups and Specifications	169 S1
STOP BOARD	188.2-3
STUDENTS	21 S5-6
T	
TAKE-OFF BOARD	184.3-4
TAKEOVER ZONES	170.3; 170.7; 170.19- 20; 214.5; 218.1; 218.4; 240.5
TEAM COMPETITION	21 S1-6; 21 S9; 240 S3
TECHNICAL DELEGATE – DUTIES	112; 146.1; 165.20 (Note); 166.2; 180.12; 180. 20; 181.8(d); 200.7
TECHNICAL MANAGER	120; Appendix 3
TECHNICAL OFFICIALS: UKA	
Accreditation to Level 4	Appendix 3
Appointments	Appendix 3
Event Management Roles	Appendix 3
Firearms Certificates	Appendix 2
Overseas Appointments	Appendix 2
Pathway	Appendix 2
Records of Officials	Appendix 2
Selection of Officials for Major Events	Appendix 3
Technical Officials' Duties	Appendix 3
Tri-Regional and National Officials Groups	Appendix 2
THROWING EVENTS – GENERAL CONDITIONS	187
THROWING EVENTS: UKA SAFETY	187 S2
THROWING EVENTS: UKA CIRCLE	187.S3
SPECIFICATION	
TIES	
Combined Events	200.12
Horizontal Jumps	180.22
Throwing Events	180.22
Track Events	167
Vertical Jumps	181.8-9
TIME CLOCK	180.18 (Note (i))
TIMEKEEPERS - DUTIES	165.4-12; 165.22; Appendix 3
Chief Timekeeper Duties	165.8-9; 165.12
Combined Events	200.8(b)

Reading and recording times	165.10; 165.11
UK Records	165 S1
World Records	260.14(a)
TIME OF COMPETITION - CHANGE	180.20
TRACK JUDGES' DUTIES	Appendix 3
TRACK MEASUREMENT	160
Certification	140
Inclination	160.6
Track Measurements: UKA	160 S1
TRAIL RACES	252
Aid Stations	252.5
Course	252.1
Equipment	252.2
Race conduct	252.6-8
Safety	252.4
Start	252.3
Trail Races: UKA	
Assistance	252 S3
Competitors' Responsibilities	252 S2
Race Conditions	252 S1
TRANSPONDER TIMING SYSTEM	165.24
For Records	260.14(a)
Judge	120; 165.25
TRIALS RECORDED (FIELD EVENTS)	142.3 (Note); 180.8
Completion of trials	180.8
Number of Trials	180.6
Order of Trials	180.5
Substitute trials	180.18
Time allowed for trials	180.17
UKA: Alteration to order of competing	180 S1-S2
UKA: Number of Trials	180 S3
TRIPLE JUMP	
Indoors	221
Landing area	184.6-7
Leaving	185.1(f); 185.2
Measurement of jump	184.8-9
Plasticine indicator board	184.5
Runway	184.1-2
Sequence of jumps	186.1-2
Sleeping leg	186.2
Take-off board	184.3-4
Take-off line	186.3-4
UKA: Under 13s not allowed to compete	141 S2 (2) (vii)
Wind measurement	184.10-12
U	
U13, U15, U17, U20 ATHLETES: SEE AGE GROUPS:	
UKA	
ULTRA RACE RULES: UKA	Appendix 1

UMPIRES - DUTIES	Appendix 3
UNATTACHED ATHLETES	2 S2; 21 S1; 21 S3
UNIVERSITIES – SEE ELIGIBILITY TO COMPETE	
UPRIGHTS	
High Jump	182.6-7; 182.9; 182.10 (Note)
Pole Vault	183.1(Note); 183.9; 183.10 (Note)
V	
VERTICAL JUMPS – GENERAL CONDITIONS	181
Combined Events	200.8 (d)
Crossbar	181.7
Extraneous Forces	181.10
Failures and Passes	181.2
Measurement	181.5-6
Placings	181.8-9
Starting Height and Height Progression	181.1-4
VICTORY CEREMONY	143.1
VIDEO RECORDING	144.3 (b); 146.3; 150; 165.24 (f)
VIDEO REFEREE	125.1; 150
VIRTUAL DISTANCE MEASUREMENT	Appendix 3
W	
WARM-UP – SEE PRACTICE TRIALS AT COMPETITION AREA	
WARNING AND DISQUALIFICATION	
Assistance	144.2
Race Walking – see Red paddle	
Referee	125.5
Start	162.7-8
WATCHES - DEFINITION	165.5
WATER AND SPONGES	163.15; 230.10; 240.8;
WATER JUMP – SEE STEEPLECHASE	
WIND GAUGE	
Certification	163.10
Horizontal Jumps	
Duration of recording	184.12
Positioning	184.11
Reading values	163.13
Mechanical gauge	163.9
Operator	120; Appendix 3
Track Events	
Duration of recording	163.12
Positioning	163.10
Reading values	163.13
Ultrasonic gauge	163.9

WORLD INDOOR RECORD	260.13; 263; 264
WORLD U20 RECORD	260.2(b)(d); 260.3(c);262; 264
WORLD RECORDS	
WRITTEN REPORTS	
Technical Delegate	112
Y	
YELLOW CARD: WARNING BY REFEREE	125.5
YELLOW FLAG: FIELD - TIME ALLOWED FOR TRIAL	180.18 (Note(i))
YELLOW PADDLE – RACE WALKING	230.5
Z	
ZERO CONTROL	165.19
ZERO CONTROL TEST FOR RECORDS	260.7(c); 260.14(a)
ZIGZAG DISTRIBUTION - TRACK HEATS	166.3

